

MPS Solutions for Automotive USB Charger

April 2020

Stella.Xiao



Outlines

- Typical Fast Charging Protocol Introduction
- MPS Solutions for All in One USB Charger
- MPS Solutions for Automotive USB PD Charger
- MPS Solutions for Automotive USB Dual Port Charger

Typical Fast Charging Protocol Introduction

Type-C Port

- **Convenience:**
Robust, slim connector with reversible plug orientation and cable direction.
- **Performance:**
Delivers up to 40Gbps supporting all of the data (USB2.0, USB3.2, USB4™) transfer and display needs.
- **USB Power Delivery:**
Delivers up to 100W-power and charging for all kinds of devices.

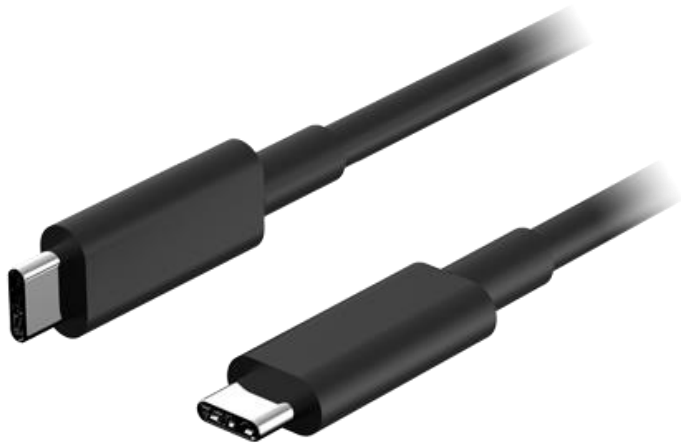

Type-C Port

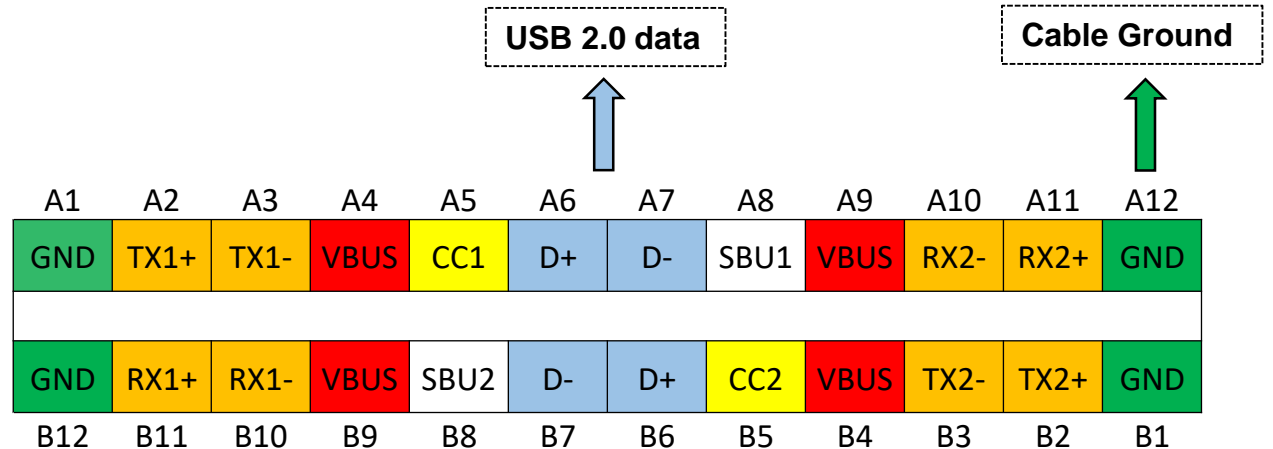

Configuration Chanel:

For cable attach, orientation, role detection and current mode.
One becomes VCONN to supply power to cable.



Cable Bus Power

Terms

- **Type-A/Type-C:**

Port Connectors evolved from a data interface capable of supplying limited power to a primary provider of power with a data interface.



USB Type-A



USB Type-C

- **CDP:**

Charging Downstream Port. A CDP provides power and meets the USB-2.0 requirements for device enumeration. The charging current should be $<1.5A$.

- **DCP:**

Dedicated Charging Port. A DCP can not enumerate a downstream device. The charging current can be $>1.5A$.

- **DFP:**

Downstream Facing Port, specifically associated with the flow of data in a USB connection. Typically the ports on a host or the ports on a hub to which devices are connected.

- **UFP:**

Upstream Facing Port, specifically associated with the flow of data in a USB connection. The port on a device or a hub that connects to a host or the DFP of a hub.

Type-C Port

• Type-C Power Summary

Precedence	Mode of Operation	Nominal Voltage	Maximum Current
Highest	USB PD	Configurable	5A
↑	USB Type-C Current @ 3.0 A	5V	3.0A
	USB Type-C Current @ 1.5 A	5V	1.5A
	USB BC 1.2	5V	Up to 1.5A
↑	Default USB Power	USB 3.2 x2 operation	1500mA*
		USB 3.2 x1 operation	900mA*
		USB 2.0	500mA*
Lowest			

*Current available depends on device and bus operating state

R_p — Indicate power supply capabilities.

R_d — Whether the power supply can be detected.

R_a — in E-marked cables(800Ω~1.2kΩ)

Figure 4-29 UFP Monitoring for Current in Pull-Up/Pull-Down CC Model

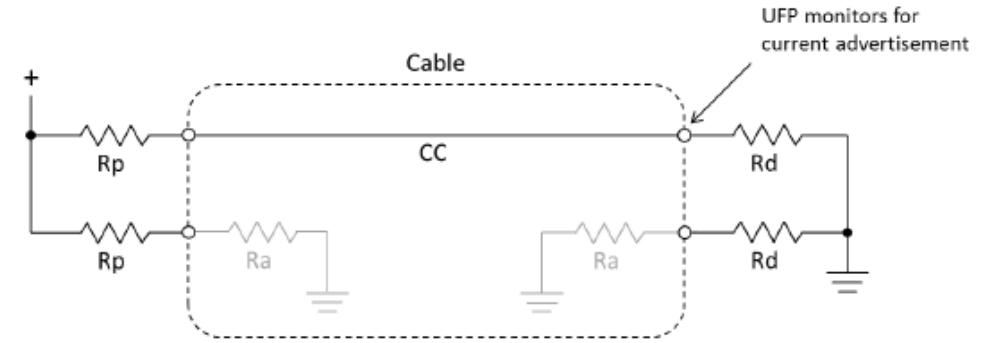

Table 4-10 DFP CC Termination (R_p) Requirements

DFP Advertisement	Current Source to 1.7 - 5.5 V	Resistor pull-up to 4.75 - 5.5 V	Resistor pull-up to 3.3 V ± 5%
Default USB Power	80 μA ± 20%	56 kΩ ± 20%	36 kΩ ± 20%
1.5 A @ 5 V	180 μA ± 8%	22 kΩ ± 5%	12 kΩ ± 5%
3.0 A @ 5 V	330 μA ± 8%	10 kΩ ± 5%	4.7 kΩ ± 5%

Table 4-11 UFP CC Termination (R_d) Requirements

R _d Implementation	Nominal value	Can detect power capability?	Max voltage on pin
± 20% voltage clamp ¹	1.1 V	No	1.32 V
± 20% resistor to GND	5.1 kΩ	No	2.18 V
± 10% resistor to GND	5.1 kΩ	Yes	2.04 V

Fast Charging Protocol for Smart Phone

Smart Phone Market Share

WORLDWIDE SMARTPHONE MARKET SHARE

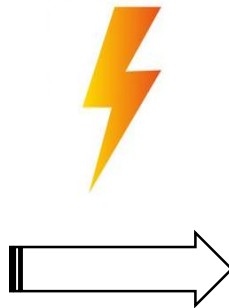
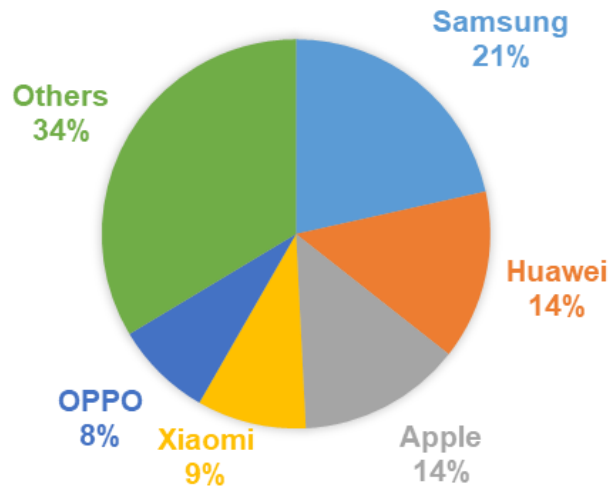

Smart Phone Fast Charging Protocol

	Voltage (V)	Current (A)	Power (W)
Power Delivery PD3.0 (PPS)	3.3-21	5	100
Quick Charge QC4.0, 4+, QC3.0	3.3-21	5	100
MTK Pump Express MTK 3.0, 4.0	3-6	5	30
Apple Charging	5V/9	3	27
Samsung AFC	5/9/12	2.1	25
Huawei FCP	5/9	2	18
Huawei SCP	5/10	4.5/4	40
OnePlus Dash/ Oppo VOOC Flash Charge	10	5	50
OnePlus Warp Charge 30	5	6	30
VIVO QC3.0	9	2	18
Turbopower Motorola (QC3.0)	5/9/12	5.7/2.85/2.15	28.5
Anker PowerIQ 2.0 (QC3.0+Apple)	5/9/12	3/2/1.5	18

Qualcomm® Quick Charge™ (QC)

- Development of QC

	Maximum Power	Voltage	Maximum Current	USB PD Compatible	Update
QC 1.0	10W	5V	2A		
QC 2.0	36W	5V/9V/12V (class A)	2A or 3A (connector dependent)		<ul style="list-style-type: none">Handshake
QC 3.0	36W	3.6V - 12V (class A)	2A or 3A (connector dependent)		<ul style="list-style-type: none">INOV: 200mV adjustable
QC 4.0	100W	3.3V - 21V	3A or 5A (connector dependent)	Compliant	<ul style="list-style-type: none">200mV → 20mVDual Charge
QC 4+	100W	3.3V - 21V	3A or 5A (connector dependent)	Compliant	<ul style="list-style-type: none">Dual ChargeIntelligent Thermal BalancingAdvanced Safety Features

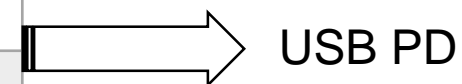

USB PD

Quick Charge 3.0 – HVDCP (High Voltage Dedicated Charging Port)

Quick Charge 3.0 employs **Intelligent Negotiation for Optimum Voltage (INOV)**, which allows your portable device to determine what power level to request at any point in time.

Qualcomm® Quick Charge™ (QC)

- Quick Charge 2.0&3.0 – HVDCP (High Voltage Dedicated Charging Port)

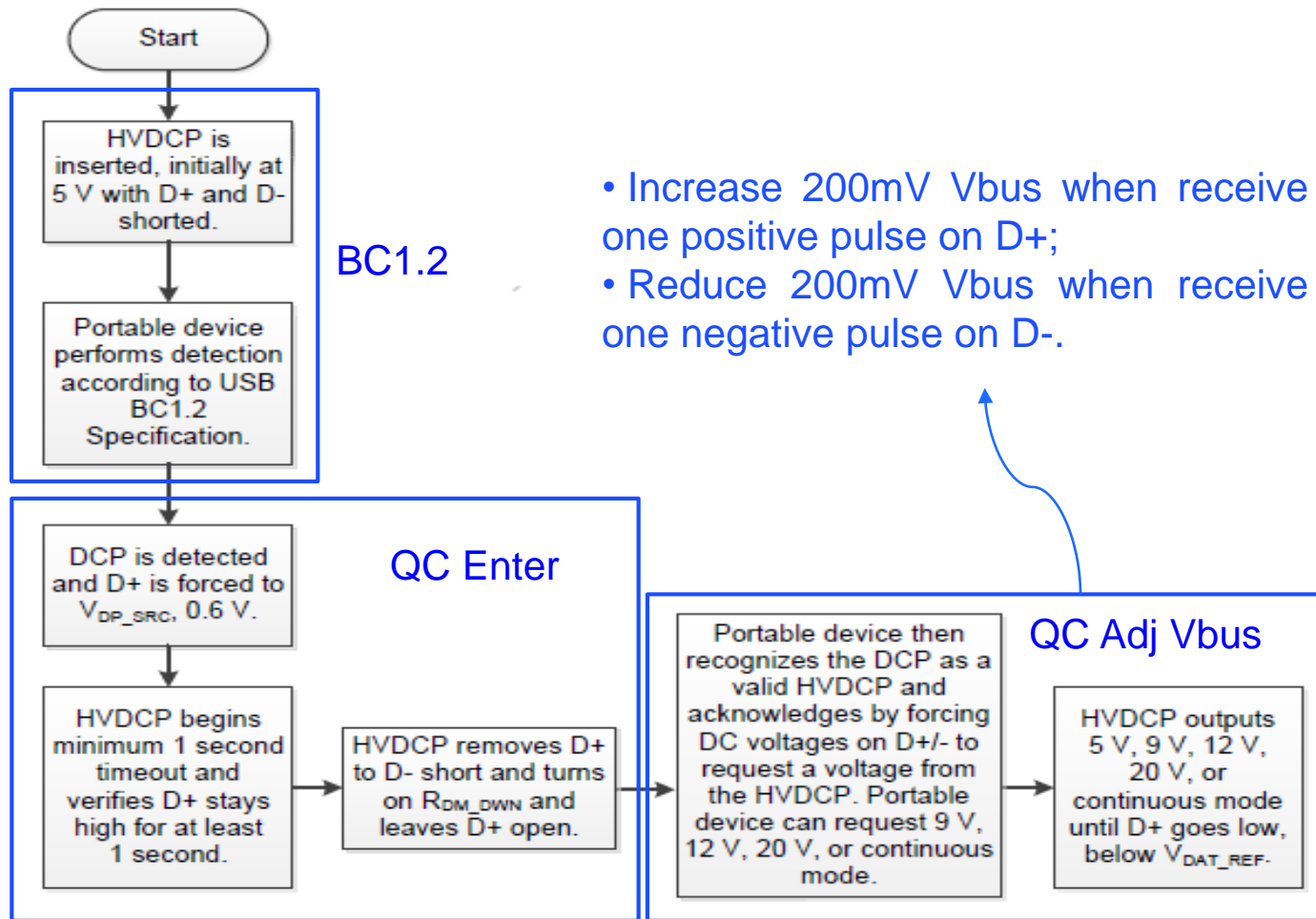

Portable Device		USB Bus Voltage
DP	DM	
0.6V	0.6V	12V
3.3V	0.6V	9V
0.6V	3.3V	3.6V-12V/200mV step according to QC3.0
3.3V	3.3V	No action
0.6V	GND	5V

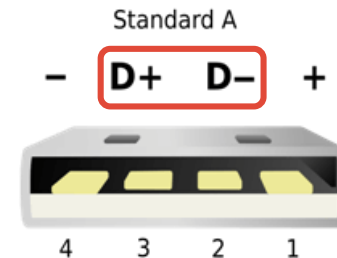

Qualcomm® Quick Charge™ (QC)

• Qualcomm® Quick Charge™ Technology Device List:



Devices

- AGM X3
- ASUS ZenFone 6*
- Black Shark 2
- BQ Aquaris X2
- BQ Aquaris X2 Pro
- Hisense U30
- Lenovo Z6 Pro*
- LG G7 ThinQ*
- LG G8 ThinQ*
- LG V40 ThinQ*
- LG V50 ThinQ*
- nubia mini
- nubia Z17
- nubia Z18
- Qiku N7 pro
- Razer Phone
- Razer Phone 2
- Redmi K20
- Redmi K20 Pro
- Redmi Note 7*
- Redmi Note 7 Pro*
- Samsung Galaxy A70
- Samsung Galaxy A80
- Smartisan R1
- Xiaomi Mi 8
- Xiaomi Mi 8 Explorer Edition
- Xiaomi Mi 8 Pro
- Xiaomi Mi 9
- Xiaomi Mi A2
- Xiaomi Mi MIX 3
- Xiaomi Mi MIX 3 5G
- Xiaomi POCO F1
- ZTE AXON Pro 9
- ZTE AXON 10 Pro



Devices

- 360 N7
- Asus ZenFone 3 Deluxe
- Baofeng Matrix (VR)
- Black Shark
- Black Shark Helo
- BlackBerry Evolve
- BlackBerry KEYone
- BlackBerry KEY2
- BlackBerry KEY2 LE
- BQ Aquaris U2
- BQ Aquaris U2 lite
- BQ Aquaris V
- BQ Aquaris V Plus
- BQ Aquarius X
- BQ Aquarius X Pro
- Coolpad Cool Changer S1
- DJI FPV goggles (VR)
- General Mobile GM5+
- GeniusIDEA Follow (drone)
- Gionee M2017
- Gionee M6S Plus
- Haier Leisure L7
- HP Elite x3
- HTC 10
- LG V20
- LG V30
- Meitu T9
- Nokia 6 (2018)
- Nokia 7 (2018)
- Nokia 8
- Nokia 9
- NuAns NEO
- Nubia X
- Nubia Z11
- Nubia Z11 Max
- Nubia Z11 miniS
- Philips EverPlay (portable speaker)
- Qiku N45
- Qiku N55
- Qiku N6
- Qiku N6 Pro
- Qiku Q5
- Qiku Q5 Plus
- Redmi Note 5
- RugGear RG760
- RugGear RG850
- Sharp Aquos R
- Sharp Aquos R Compact

MPS Certified QC3.0 Charger

Monolithic Power Systems

- MP5034

MPS

- MPQ4482GR Q AEC1

USB Power Delivery (PD)

Development of USB PD

PD2.0

- Fixed Power Supply
- Voltage: 5V/9V/15V/20V
- Current: 1.5A/2A/3A/5A

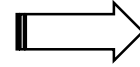

PD3.0

- PPS (Programmable Power Supply)
- Voltage: 3.3V~21V (*20mV/step adj*)
- Current: 3A or 5A (*50mA/step adj*)

Figure 10-1 Source Power Rule Illustration

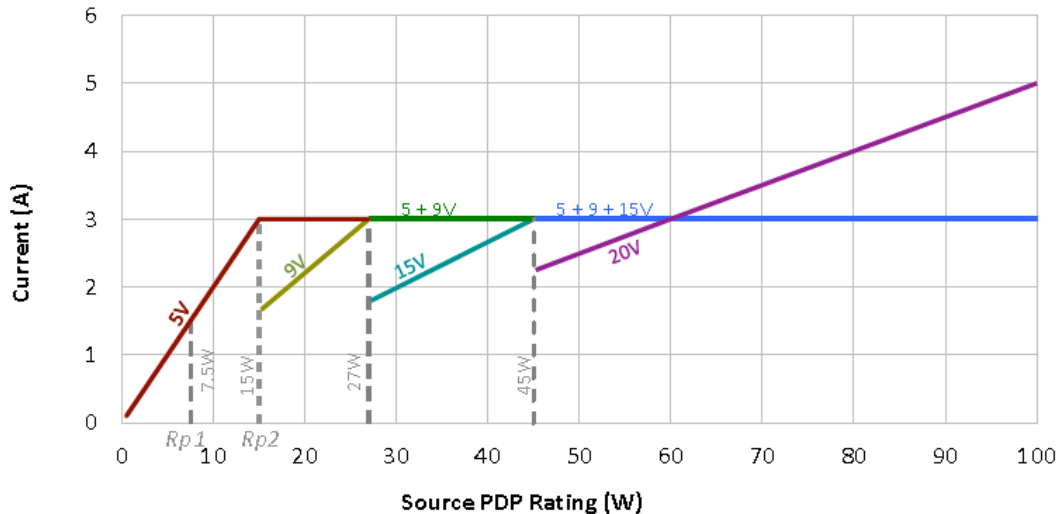

Table 10-8 Programmable Power Supply Voltage Ranges

	Fixed Nominal Voltage			
	5V Prog	9V Prog	15V Prog	20V Prog
Maximum Voltage	5.9V	11V	16V	21V
Minimum Voltage	3.3V	3.3V	3.3V	3.3V

The voltages and currents of a Source with a PDP of x W Shall support :

Table 10-2 Normative Voltages and Minimum Currents

PDP Rating (W)	Current at 5V (A)	Current at 9V (A)	Current at 15V (A)	Current at 20V (A)
$0.5 \leq x \leq 15$	$x + 5$			
$15 < x \leq 27$	3	$x + 9$		
$27 < x \leq 45$	3	3	$x + 15$	
$45 < x \leq 60$	3	3	3	$x + 20$
$60 < x \leq 100$	3	3	3	$x + 20^1$

¹ Requires a 5A cable.

USB Power Delivery (PD)

- USB PD System Overview

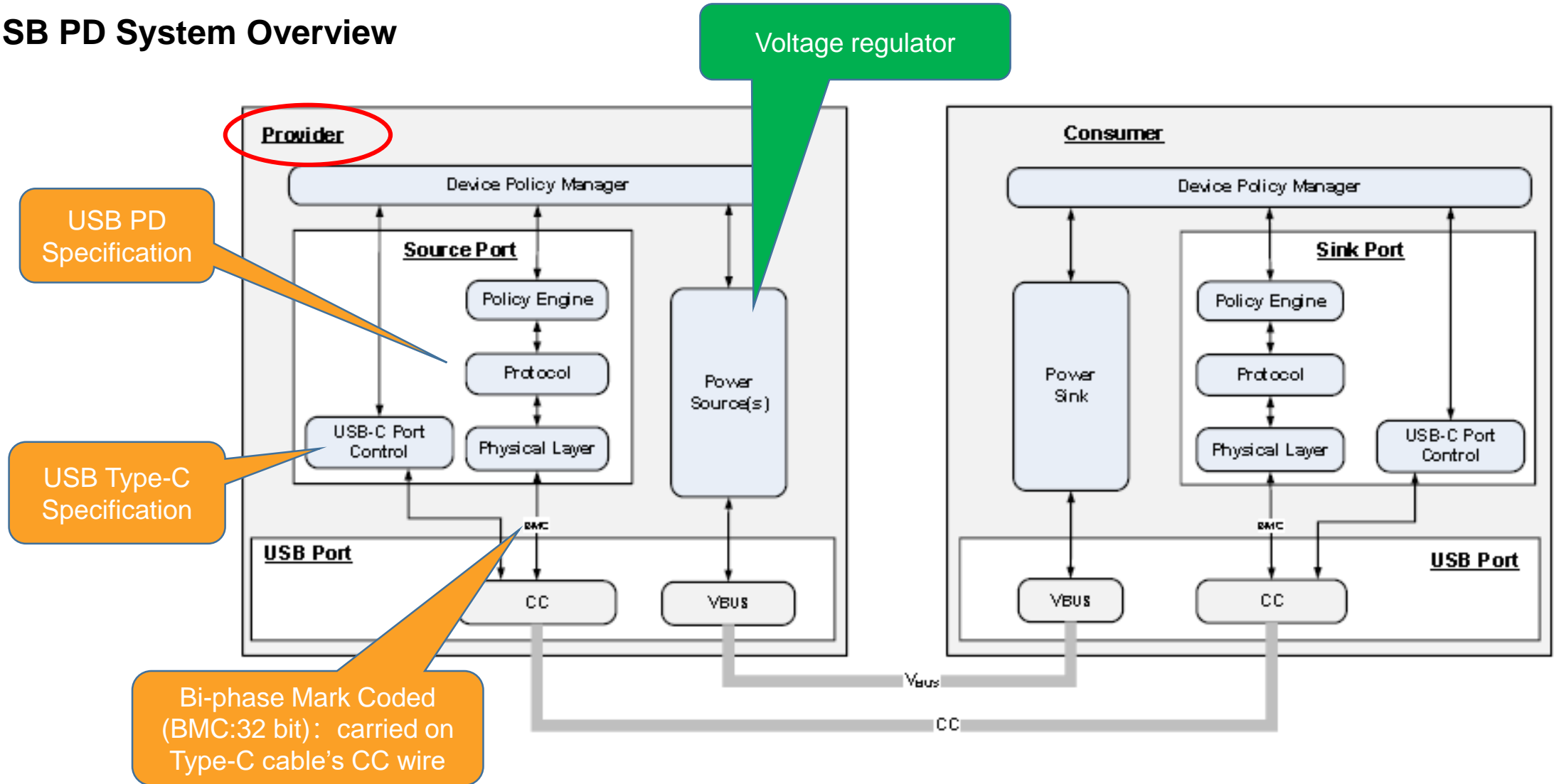

MPS Solutions for All in One USB Charger

Target Applications Design of Automotive USB Charger

- Target Applications of Automotive USB Charger



- Type-A
- Type-C

- Charging Port
- Data Port

- Single Port
- Dual Port

Step 1.

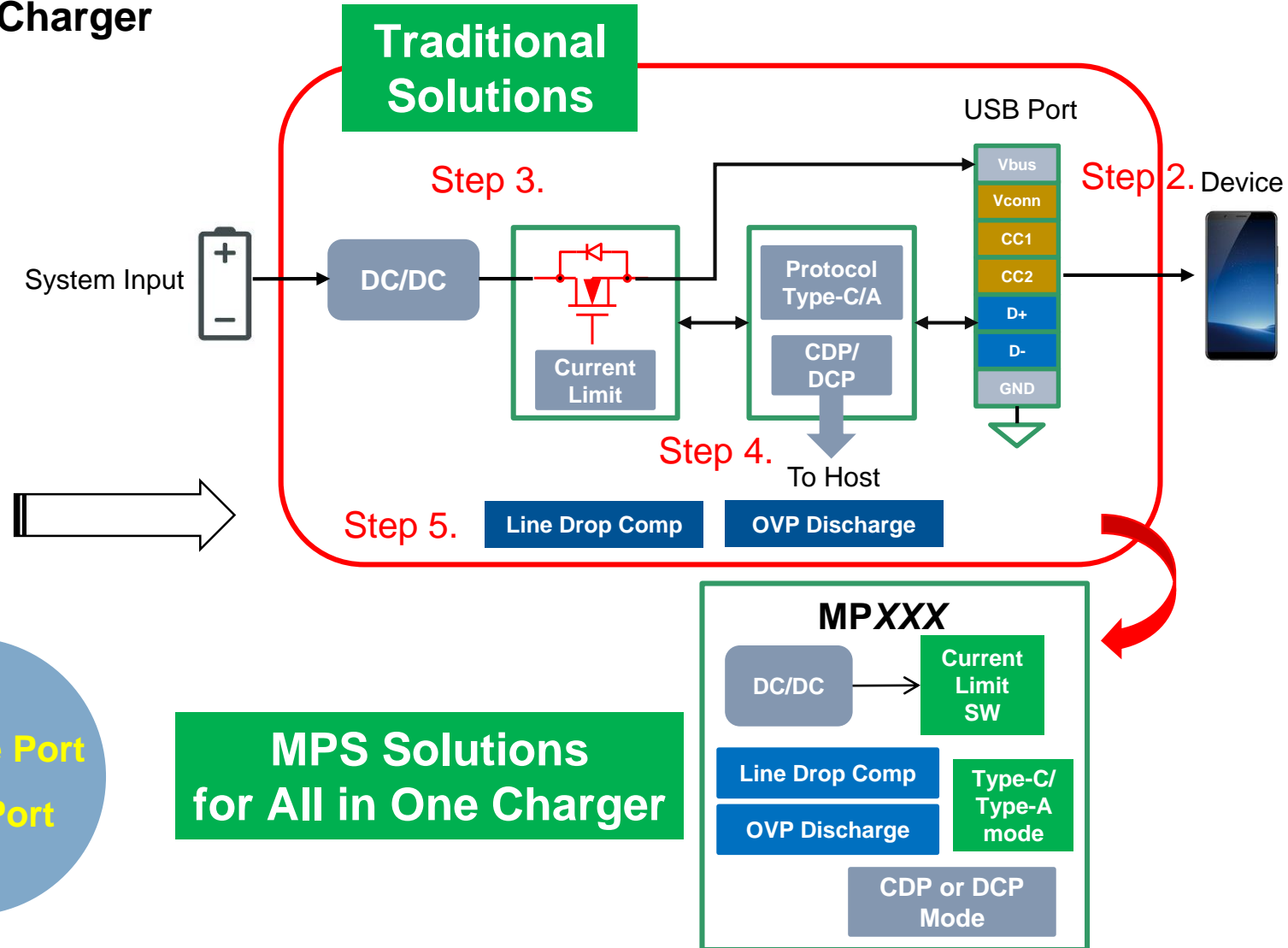

MPS Solutions for All in One Charger

Monolithic Single Chip Solution up to 1000V

- Fabless proprietary process technology
- Using most advanced fab equipment for analog power

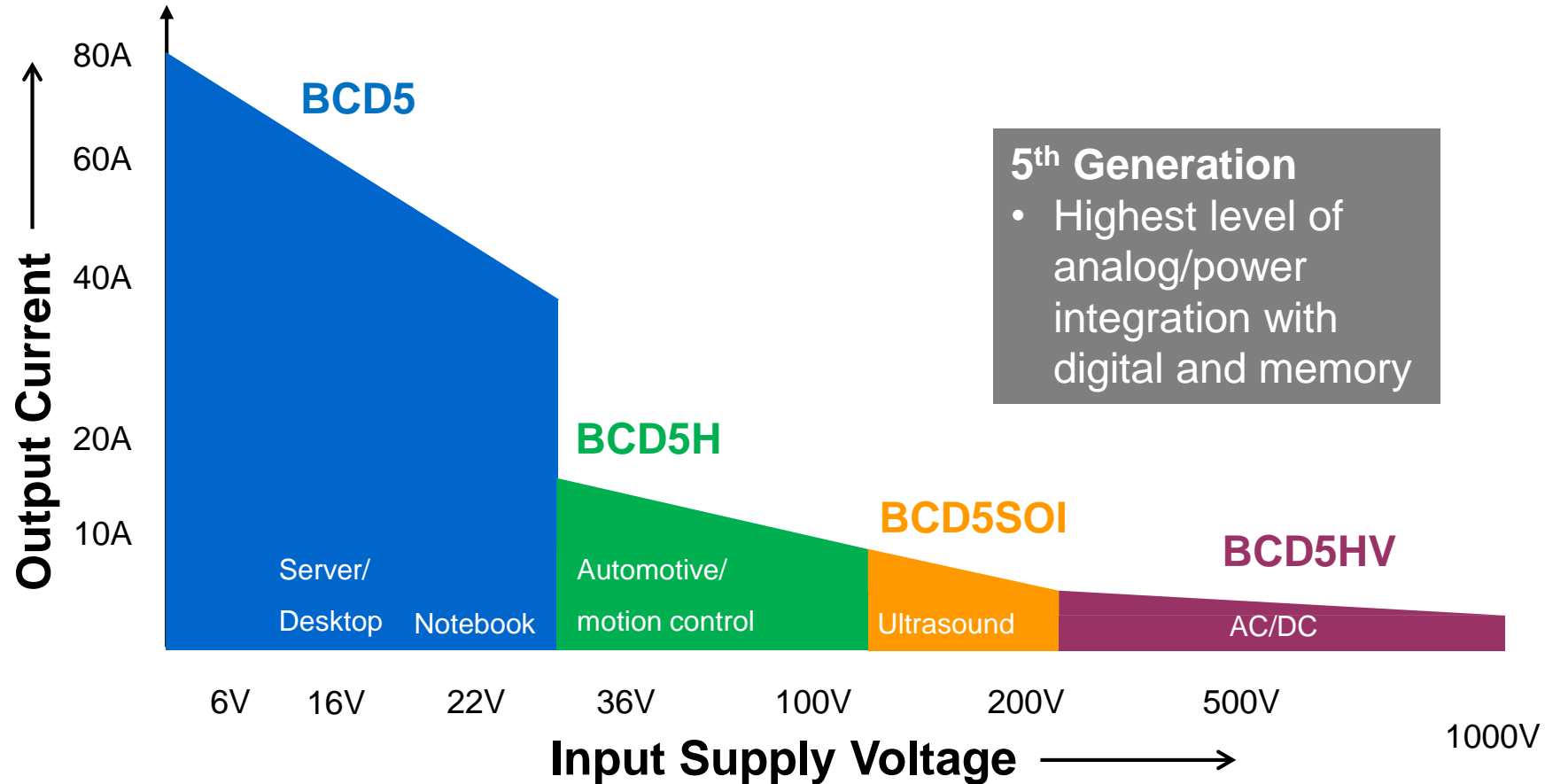

Typical Package Cross Section

Wire Bond

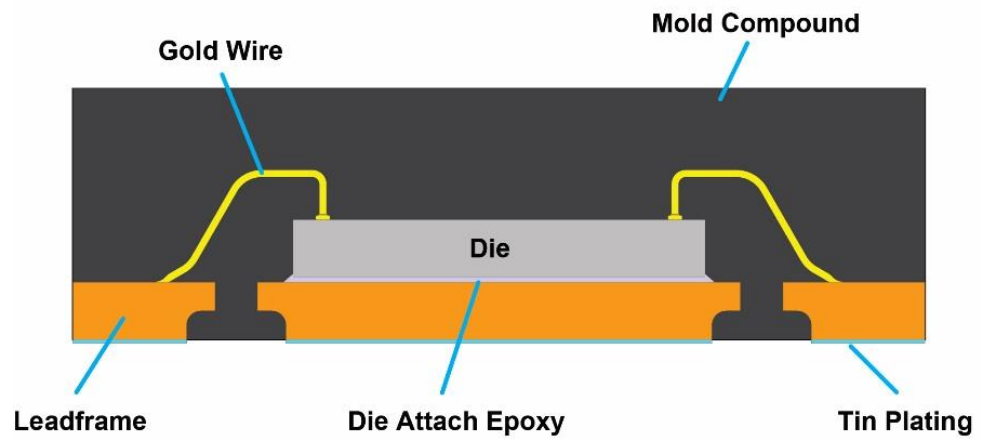

MPS Mesh Connect™ (No Wire Bond)

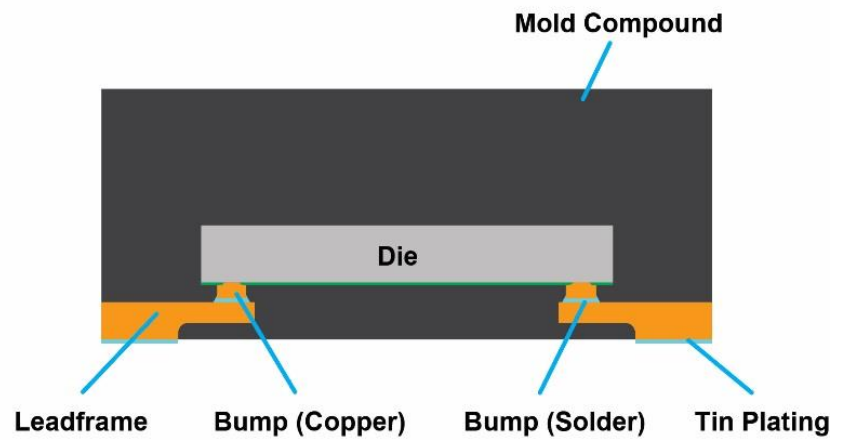

High Reliability, Small Form Factor, Better Heat Design,
No Inductance, and Faster Response

MPQ4482/-Q, All-in-one Single port, Type C/QC

FEATURES

- All-in-One Solution: Buck + USB SW + One Type-C DFP (w/o USB PD) 5V @ 3A + **QC3.0 Protocol**
- 4 - 36V Operation, 40V Transient Voltage SYNC Buck
- 3.6V-12V/3A Output Current
- Selectable FREQ and SYNC In
- **Vbus, CC lines and DP/DM Short to Battery Protect**
- Support QC3.0 and BC1.2/Apple divider Mode
- Precision OCP: 3.55A
- **Line Drop Compensation**
- Adjust Output Voltage
- Thermal Foldback
- OCP with Hiccup Mode

APPLICATIONS

- QC3.0 Charging Port

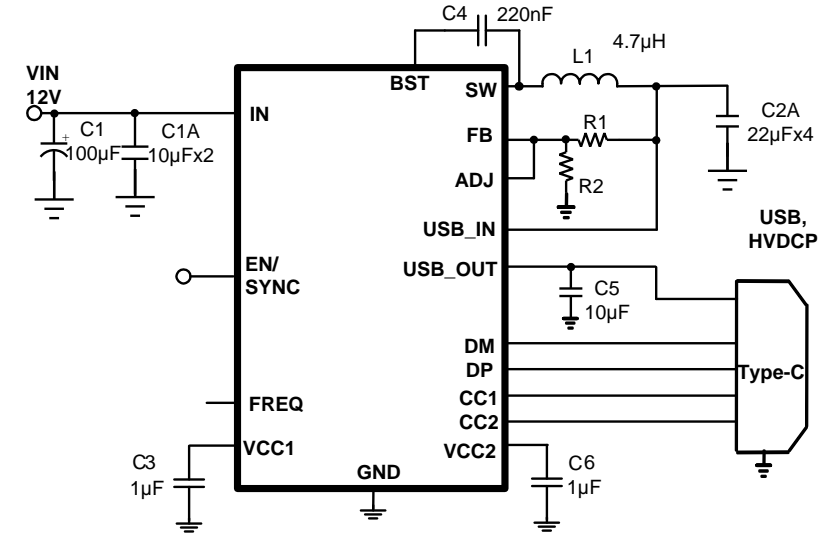

Available in a QFN (4mmx4mm) Package

MPQ4482-C: USB A or C with CDP

FEATURES

- All-in-One Solution: Buck + USB SW + One Type-C DFP (w/o USB PD) 5V @ 3A + **CDP/DCP Type-A mode**
- 6 - 36V Operation, 40V Transient Voltage SYNC Buck
- 2.4A or 3A Output Current
- Selectable FREQ and SYNC In
- **Vbus, CC lines and DP/DM Short to Battery Protect**
- **Support CDP Mode**
- **Integrated 480MHz USB2.0 Data Switch**
- Precision OCP: 3.55A
- **Line Drop Compensation**
- Adjust Output Voltage
- Thermal Foldback
- OCP with Hiccup Mode

APPLICATIONS

- Infotainment
- USB Hub

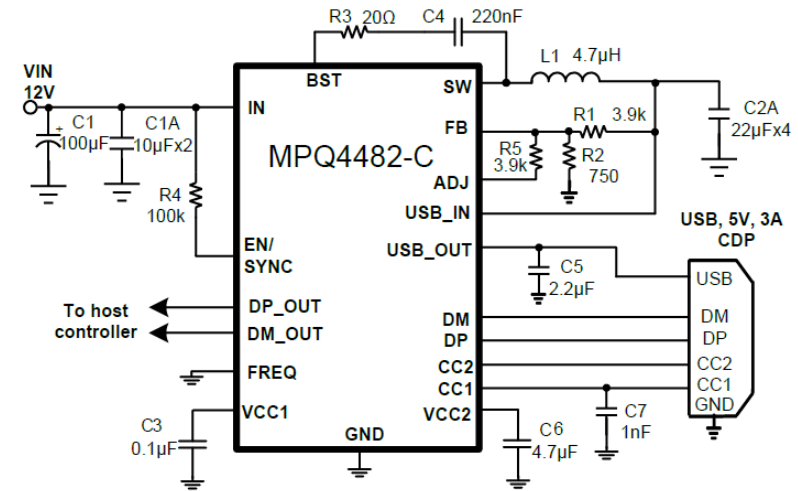

Available in a QFN (4mmx4mm) Package

Eye Diagram

Measured on EVB based on Figure 12 with 50cm Cable with MPQ4482-C Data Switch

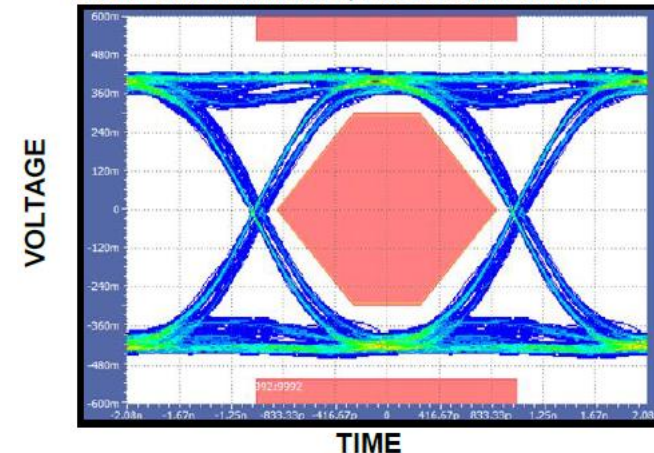

MPQ4228, MPQ4228-C, 3A/2.2MHz USB-C

FEATURES

- All-in-One Solution: Buck + USB SW + One Type-C DFP (w/o USB PD) 5V @ 3A + CDP Type-A mode,
- 6 - 36V Operation, 40V Transient Voltage SYNC Buck
- 3A USB, 5.5A Buck Output Current
- High Efficiency Buck Regulator Supporting 5.5A Iout
- 2.2MHz, 450kHz and Frequency Spread Spectrum
- Output Bias VCC LDO Integrated
- Vbus, CC lines and DP/DM Short to Battery Protect
- Support DCP(MPQ4228) CDP(MPQ4228-C) Mode
- Integrated 480MHz USB2.0 Data Switch (MPQ4228-C)
- Precision OCP: 3.55A
- Meet USB-IF BC1.2 Spec, Apple MFI R32 Spec
- Adjustable Line Drop Compensation
- IEC +-8kV Contact/15kV Air discharge ESD for I/O pins
- Adjustable Output Voltage
- Thermal Foldback
- OCP with Hiccup Mode

APPLICATIONS

- Infotainment
- Charging Only USB-C/A Port
- USB Hub

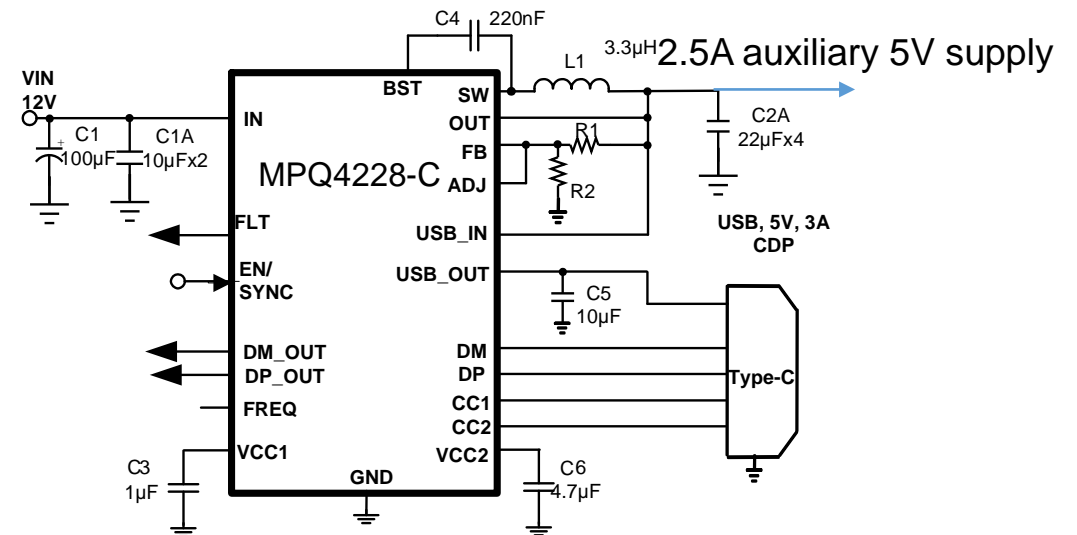

Available in a QFN (4mmx4mm) Package

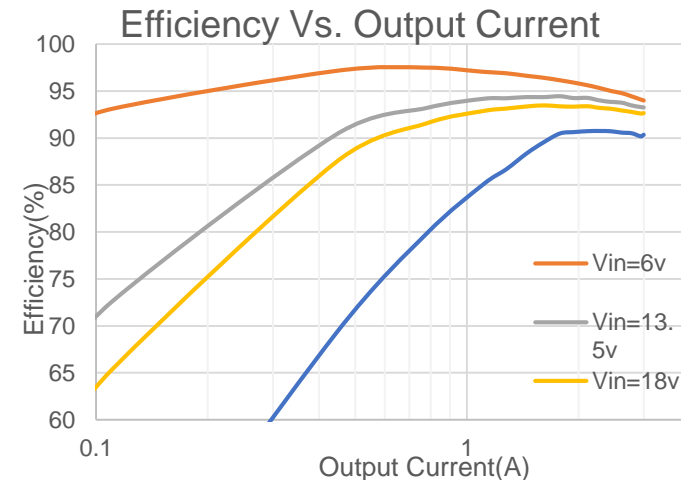

Up to 93.4% efficiency at 3A output @ 420kHz

MPQ4228, MPQ4228-C, 3A/2.2MHz USB-C

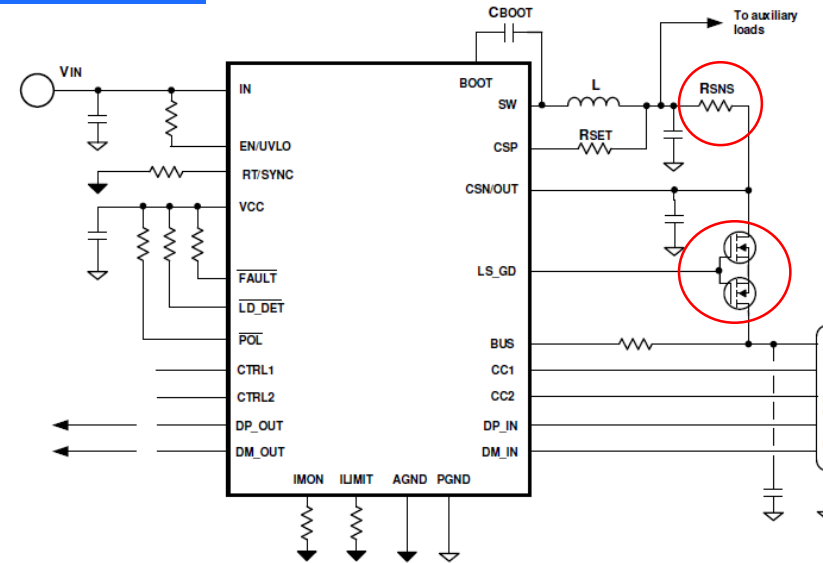
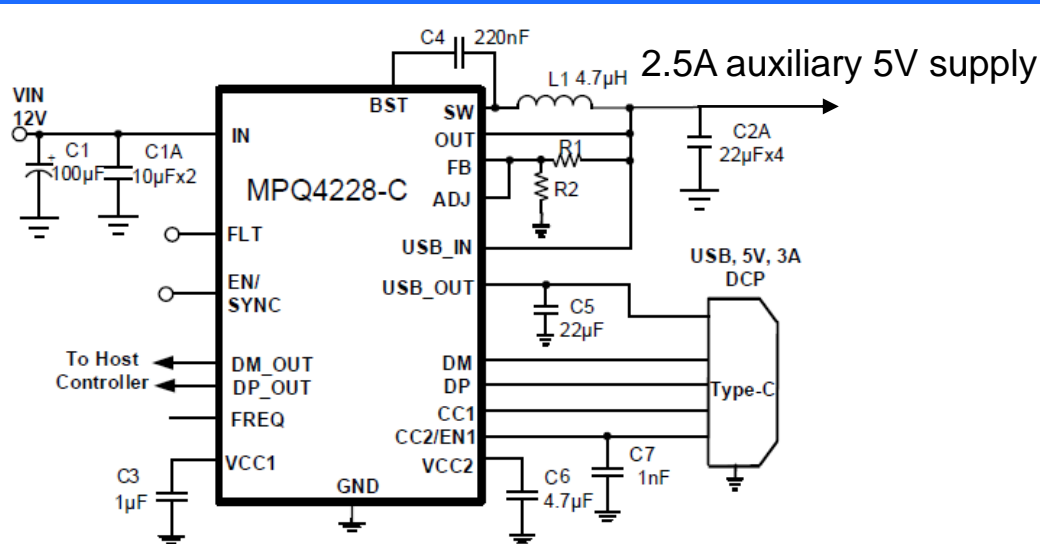

Item	MPQ4228-C	Competitor
BOM	QFN4x4 w/ integrated 24V/20mΩ USB Switch	QFN5x5, need ext. Rsens Ext. USB FET to support auxiliary 5V supply
Load Shedding Supporting	Yes, One die temp sense. Support Type-A mode load shedding as well.	External NTC, not support Type-A load shedding
Type-A Mode	Yes	No
USB2.0 Data Switch	2Ω Ron, less signal attenuation	4.3Ω Ron, eye diagram NG
MFI R32 Support	Yes	2.7V/2.7V divider mode(2.4A), Can't meet OVP, OCP spec
Buck Rds(on)	50mΩ/30mΩ	40mΩ/35mΩ
DP/DM Short to Battery	Ok	Vbus will charge to battery (12V), may damage the auxiliary device

MPS Solutions for Automotive USB PD Charger

USB Certified 60W USB PD 3.0+PPS

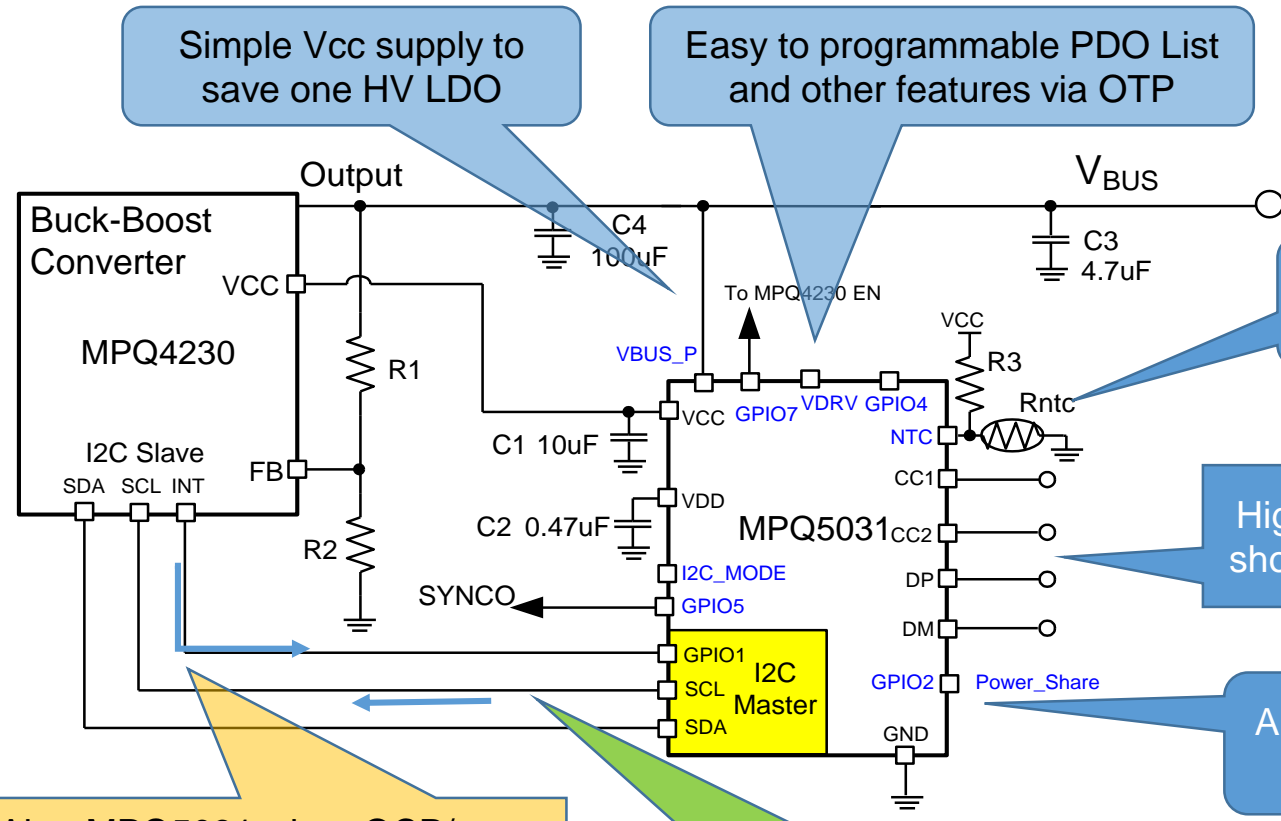

Simple Vcc supply to save one HV LDO

Easy to programmable PDO List and other features via OTP

Thermal sense for USB-C Connector protect

High voltage I/O pins: short to batt protection

Auto Power share for 2 PD ports

MPQ4230 Alert MPQ5031 when OCP/over temp happens via INT pin

MPQ5031 set Vbus and Iout_CC threshold via i2c. Accurate, stable and simple!

USB Certified 100W USB PD 3.0+PPS

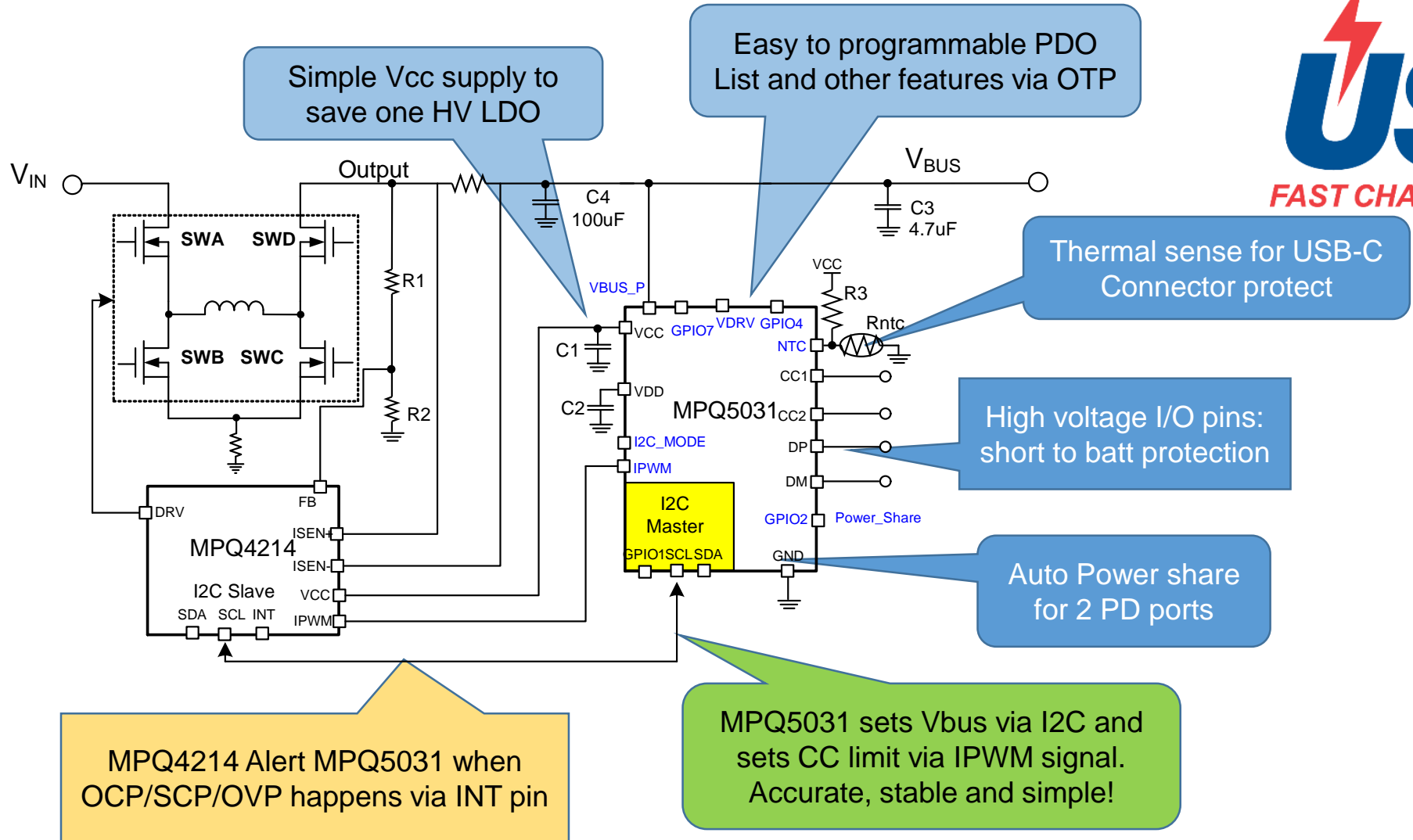

Complete USB-PD Solution (MPQ5031 + MPQ4230/MPQ4214)

- MPS Total Solution is optimized, certified, easy to use, low BOM count and smaller solution size while maintaining flexibility with user programming capability

Items	MPQ5031	Competition
Cost	Less expensive – tailored and optimized for USB PD with needed hardware + memories, I2C master/slave for USB PD.	More expensive– a lot of overhead, it's ARM core and flash memory; Also lots of other function option which is not needed for USB PD.
BOM	MPS total solution MPQ4230/4214+MPQ5031 for 60W/100W, output CV/CC control via two wire I2C control, simple, accurate, slew rate control and easy schematic.	VFB based CV/CC control for PPS, hard to tune the control loop stability, complicated schematic.
DP/DM Function	High voltage pin; support Apple charging, short mode, QC3.0 and Huawei FCP charging modes; Strong 24V ESD protect.	No such function and just has low voltage GPIO.
Integrated Vconn	Yes and with short to battery protection.	Need external Vconn switch and no short to battery protection.
Power Share	Yes, and only needs one GPIO for communication between two ports.	Yes, but needs 3 GPIOs for communication between two ports.
External LDO	Not needed. It has EN_MID output which can disable MPQ4230 Vbus but keep VCC alive .	Needed. Because no reverse block when Vconn has OVP, which may potential damage Vcc.
Vbus Isolation FET	Support low cost NMOSFET.	Only support PMOSFET which has SCP issue at 3.3Vin.
Firmware	Easy to use, user can program it by i2c GUI easily.	Require AE supporting to do FW change.

Complete USB-PD Solution (MPQ5031 + MPQ4230/MPQ4214)

MPQ4230/4231 FEATURES

- Support 60W Buck-Boost or 5A Peak Iout (MPQ4230)
- Support 45W Buck-Boost or 3A Peak Iout (MPQ4231)
- Wide 3.4V to 36V Operating Input Voltage Range
- 0.4V to 20.47V Output-Voltage Range, 10mV Resolution
- 250kHz, 350kHz and 420kHz Frequency Selectable
- Frequency Spread Spectrum Selectable
- Line Drop Compensation
- Accurate CC Output-Current Limit, 50mA/step, $\pm 5\%$
- I²C Interface with ALT
- PFM/PWM Mode, Current Limit, Output Voltage, Frequency Spread Spectrum, Line Drop Comp, etc.
- CRC Check for MTP Integrity
- Battery Short to Ground Protection Driver
- Load Shedding Send Alert
- EN Shutdown Active Discharge

APPLICATIONS

- USB Type-C Port/Hub
- USB Dedicated Charging Ports (DCP)

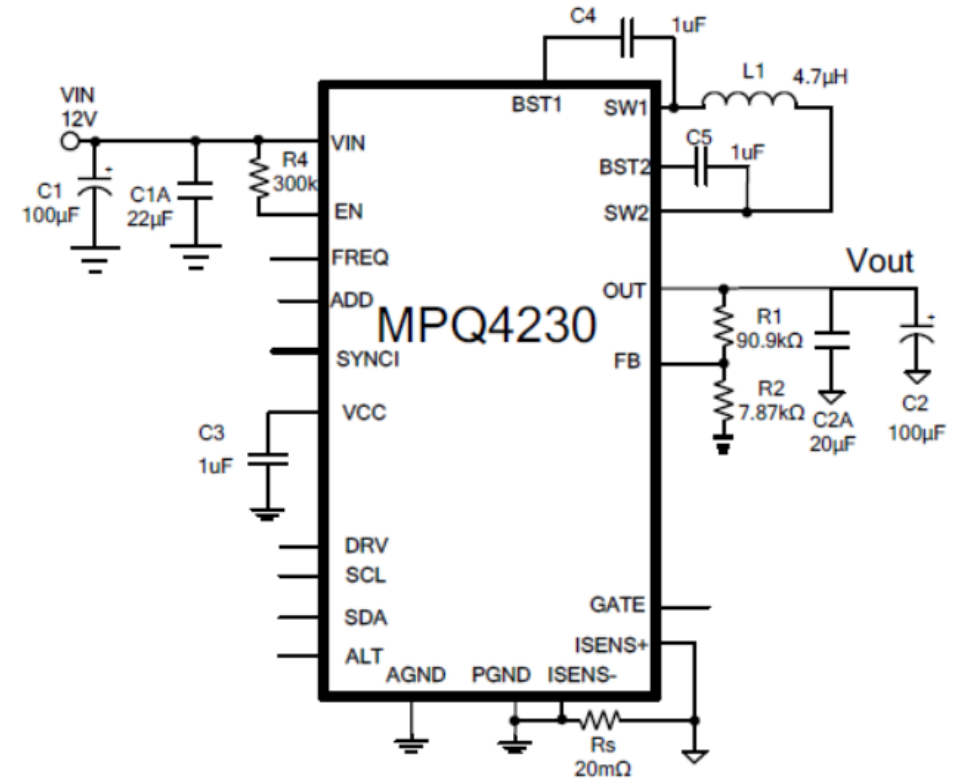

QFN-21 (4mmx5mm) Package with Wettable Flanks

Complete USB-PD Solution (MPQ5031 + MPQ4230/MPQ4214)

MPQ4214 FEATURES

- 4V to 40V Wide Input Voltage Range
- Programmable 0.3V to 2.047V VREF with 1mV Step
- IPWM Programmable CC current limit
- **Integrated VOUT Discharge Function**
- Programmable Average Current Limit
- I2C interface with INT
- Selectable PSM, and FCCM
- Selectable 200kHz, 300kHz, 400kHz, and 600kHz Frequency
- 7.2V / 2A MOSFET Gate Drivers
- OCP/SCP/OVP
- Available in AEC-Q100 Qualified Grade

APPLICATIONS

- USB Power Delivery
- Industrial PC Power Supplies
- Automotive Start-Stop Systems

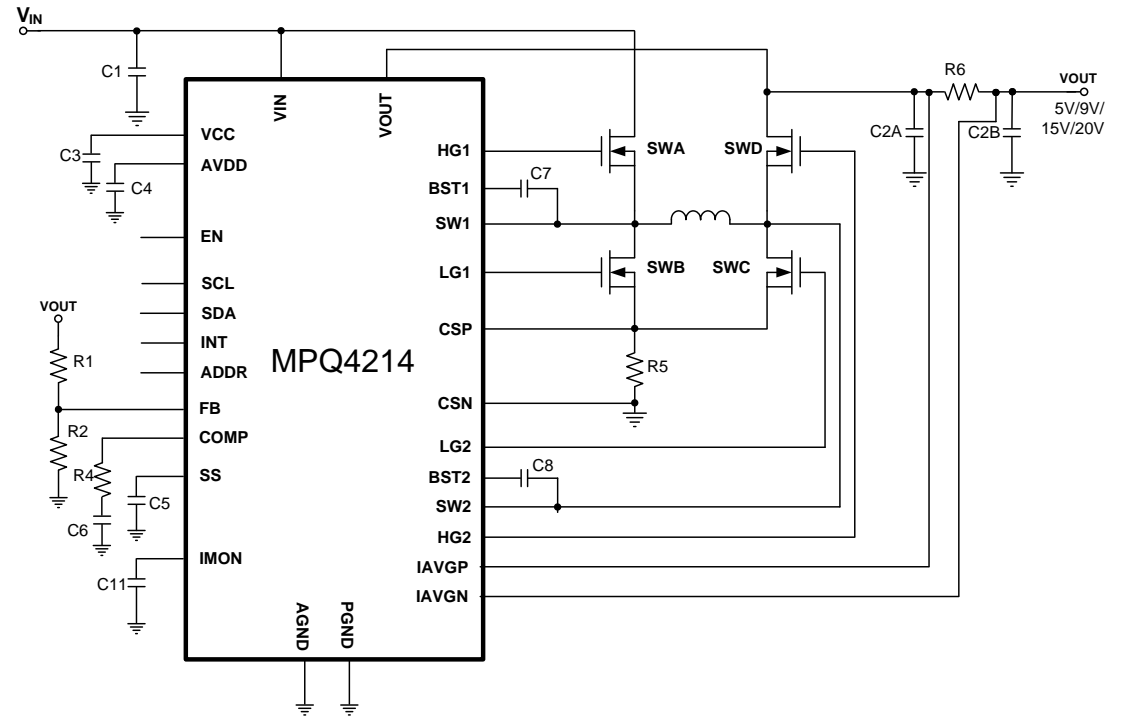

Available in a QFN (5mmx5mm) Package

Dual Channel PD Supply

Simple BOM for dual channel PD supply

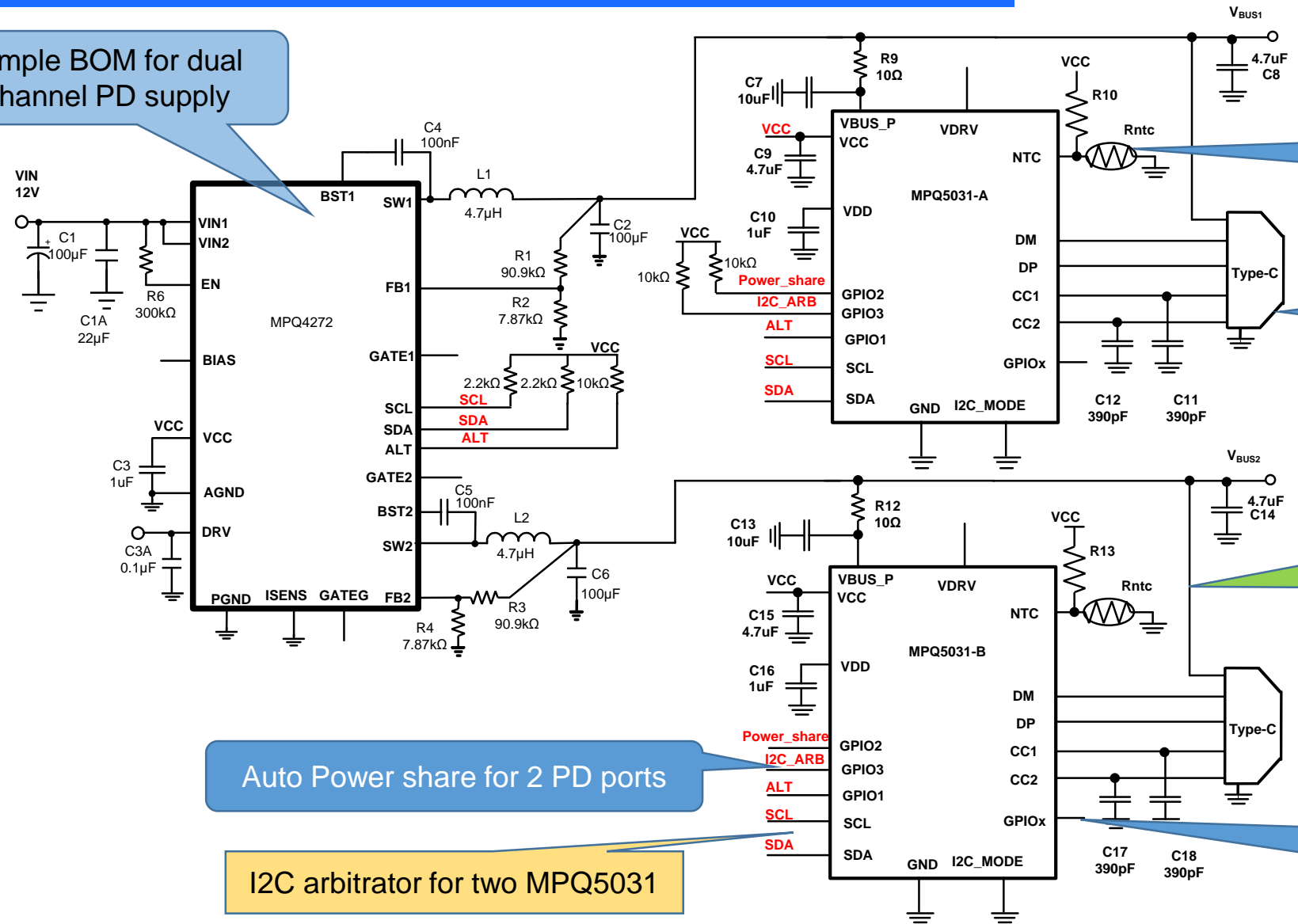

Thermal sense for USB-C Connector protect

High voltage I/O pins: short to batt protection

MPQ5031 set Vbus and Iout_CC threshold via i2c. Accurate, stable and simple!

Auto Power share for 2 PD ports

I2C arbitrator for two MPQ5031

Multi-functional GPIOx pins, like VBATT sense low to reduce PDO, NTC2 load shedding, etc.

Dual Channel PD Supply

MPQ4272 FEATURES

- **Dual 36V/3A Buck Converter**
- Wide 3.4V to 36V Operating Input-Voltage Range
- 0.4V to 20.47V or $V_{in} \cdot D_{MAX}$ Output-Voltage Range, 10mV resolution
- 250kHz/420kHz/1.1MHz/2.1MHz Selectable Switching Frequency
- Frequency Spread Spectrum
- **Low Dropout Mode**
- Line Drop Compensation
- Accurate +/-5% adjustable CC Output-Current Limit 50mA/step via I2C
- Battery Short to Ground Protection Driver
- I/O Pin Short to Battery Protection Driver
- VBUS Isolation NMOS Gate Driver
- EN Shutdown Passive Discharge

APPLICATIONS

- USB Power Delivery
- Industrial PC Power Supplies

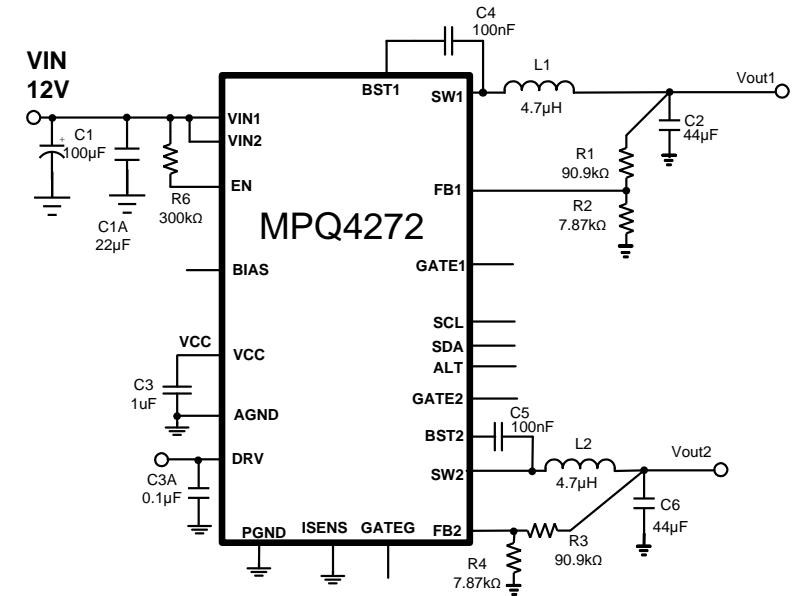

Available in a QFN (4mmx5mm) Package with Wettable Flanks

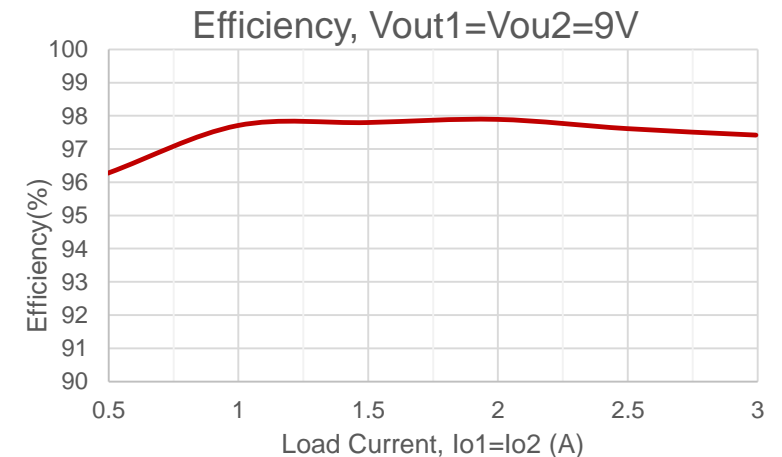

MPS Solutions for Automotive USB Dual Port Charger

Dual Type-C Charging only/Hub Ports

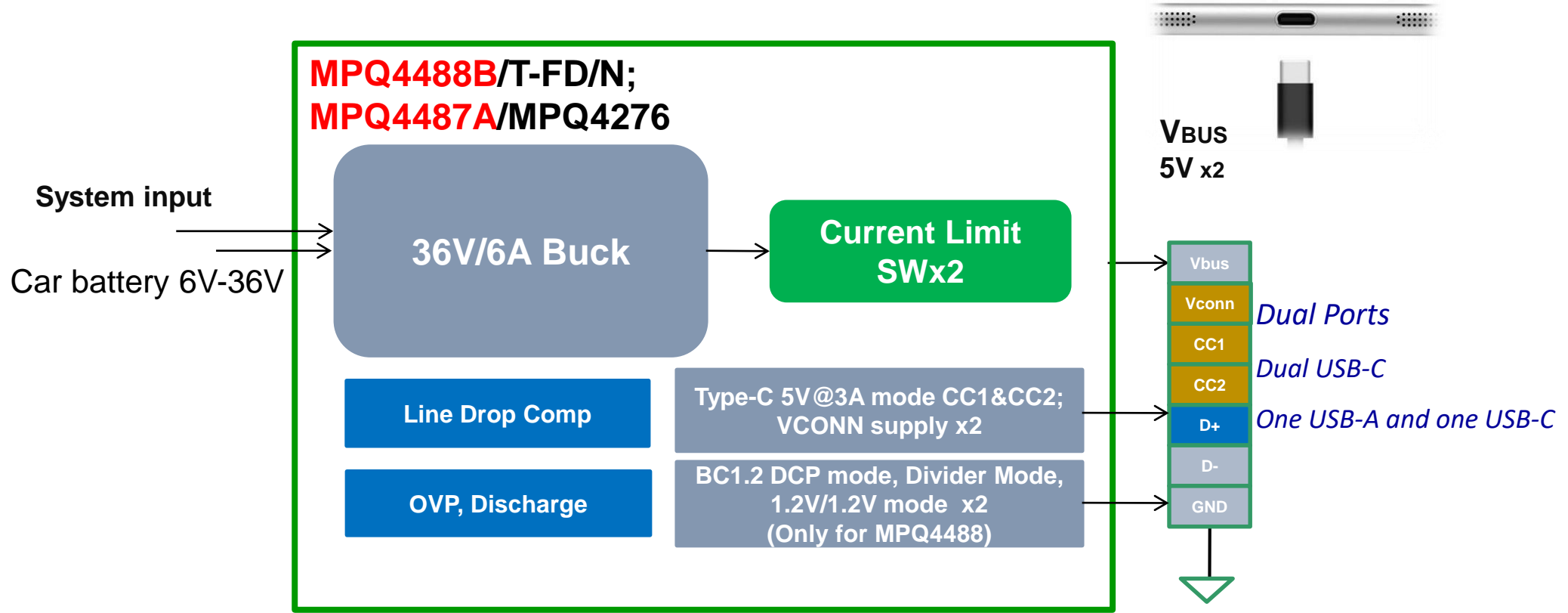

APPLICATIONS

- Automotive USB Type-C Charging Ports
- Automotive HUB USB Ports
- USB Dedicated Charging Ports (DCP) (For MPQ4488)

1xCDP Type-A + 1xDACP Type-C/A

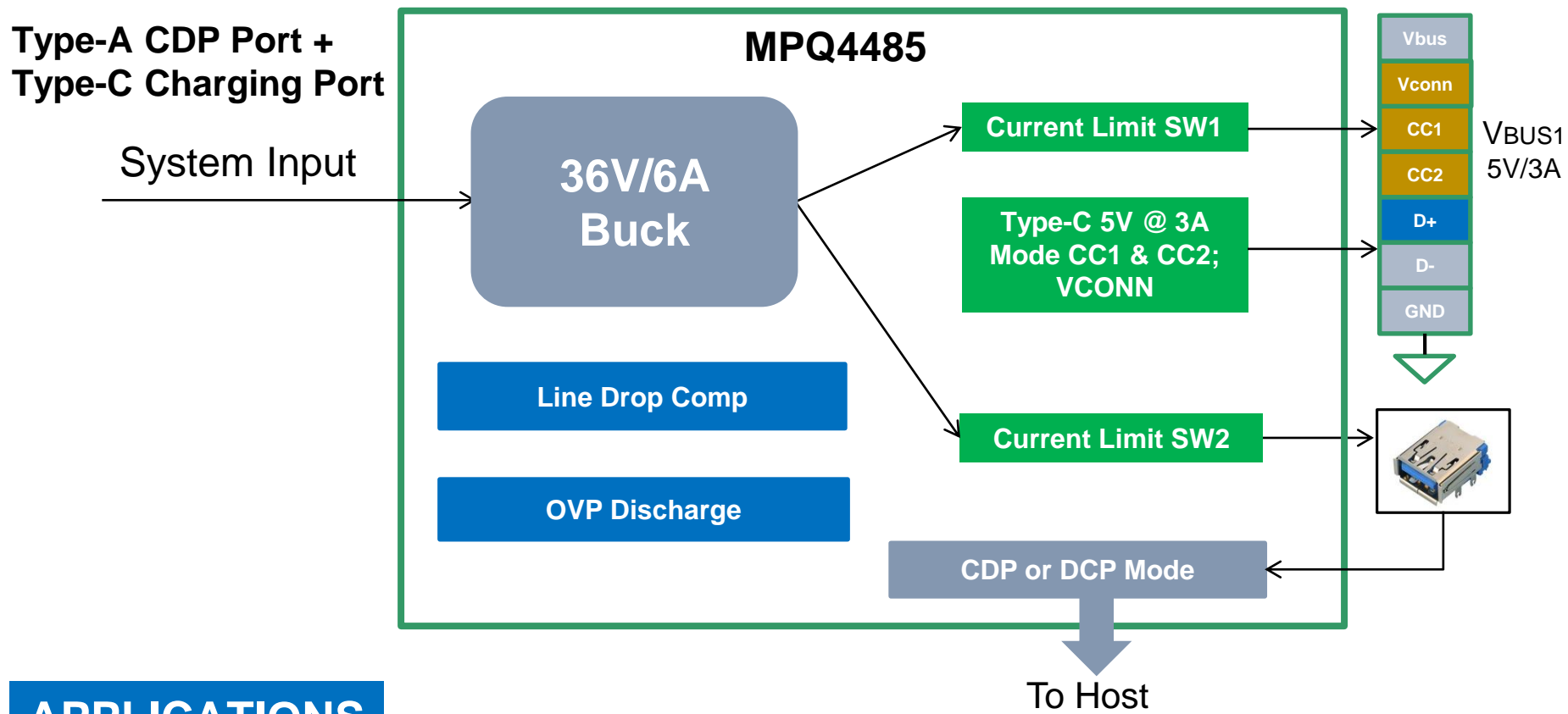

APPLICATIONS

- USB Charging Downstream Port (CDP)
- USB Dedicated Charging Ports (DCP)
- USB Type-C Charging Port

Integrated Buck and High-Speed Data Switch
High ESD Rating for the Data Switch

Dual CDP/DCP/Type-C

Dual Type-C Ports
with Short-to
Battery Protection

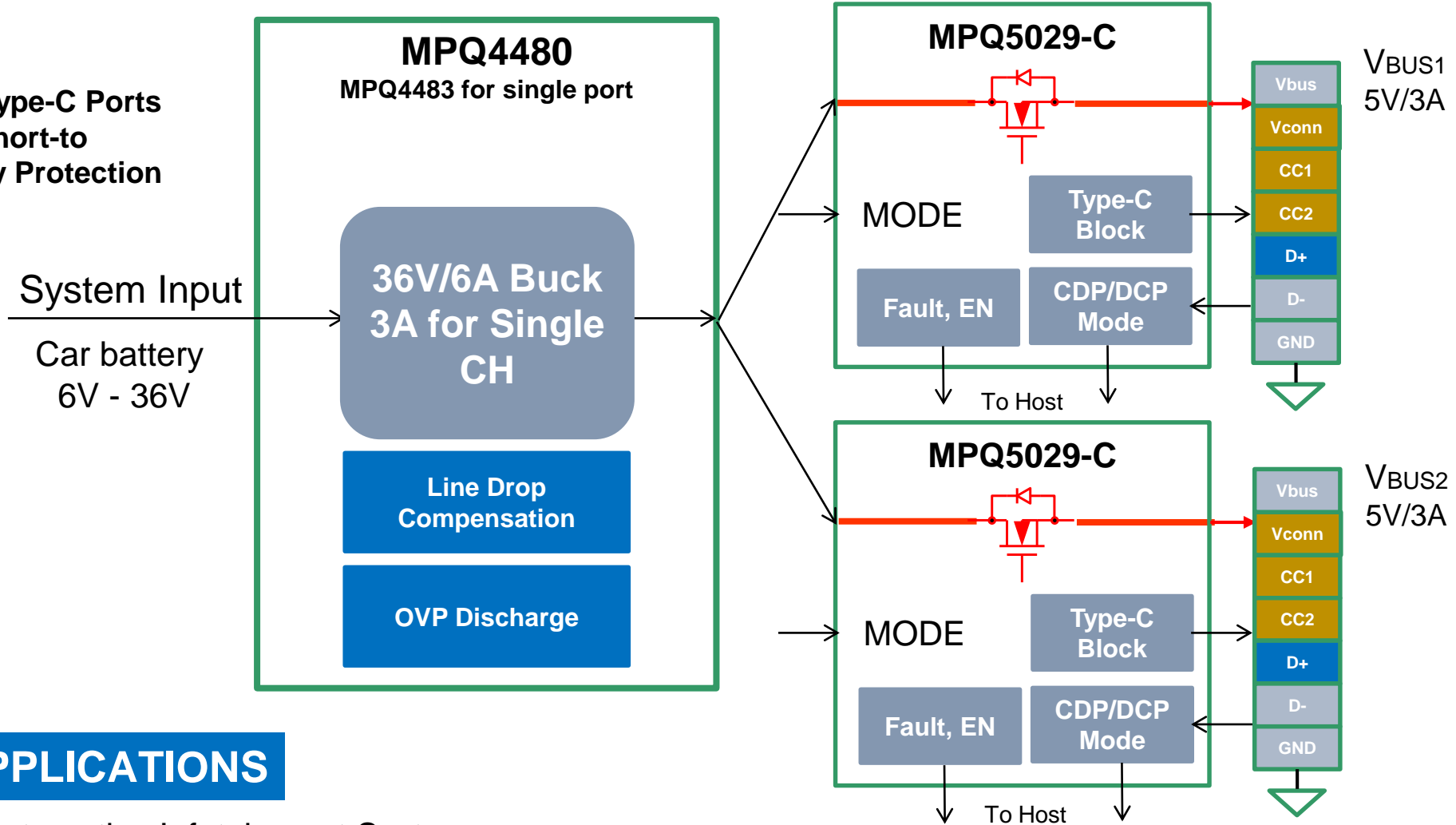

APPLICATIONS

- Automotive Infotainment System
- Automotive USB Hub

Short-to-battery protection for Vbus, CC1/2, D+/D-, GND

1xType-C + 1xType-A DCP

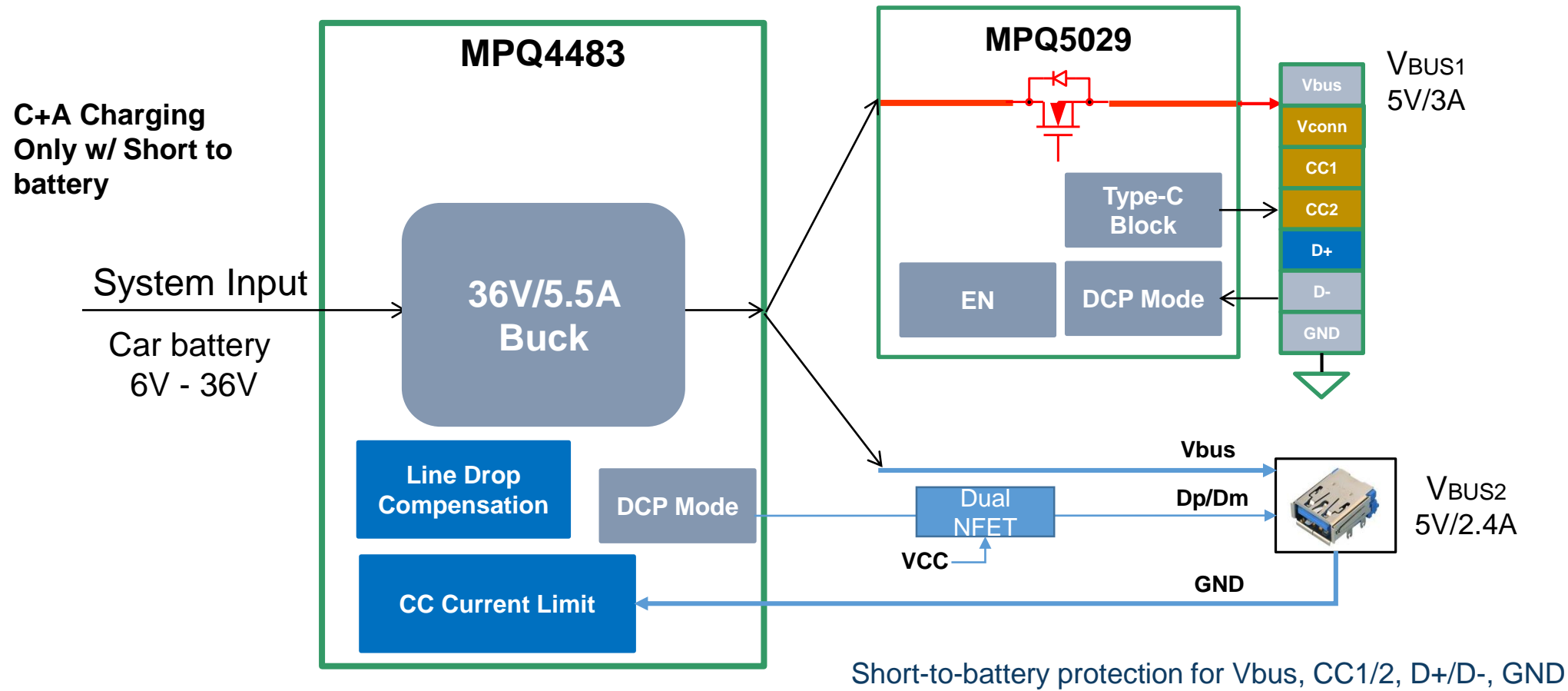

APPLICATIONS

- Automotive Charging Only Port

Automotive USB Charging Products Roadmap

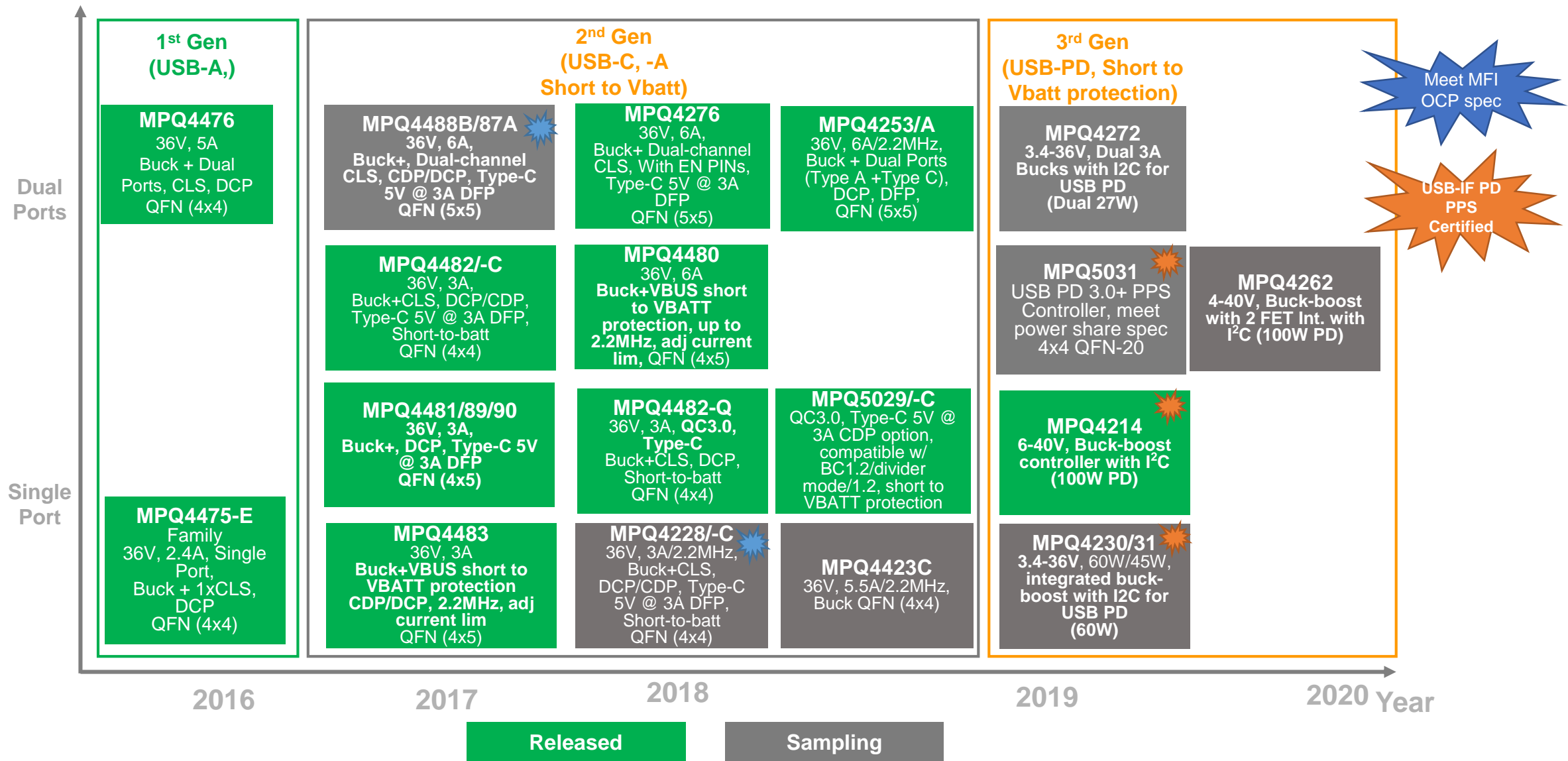

References & Links

- Monolithic Power Systems (MPS) www.monolithicpower.com
- Universal Serial Bus Type-C Cable and Connector Specification 1.0
- Universal Serial Bus Power Delivery Specification 3.0
- Battery Charging Specification 1.2

Thank You