

MPS[®]

MPS[®]

Monolithic Power Systems[®]

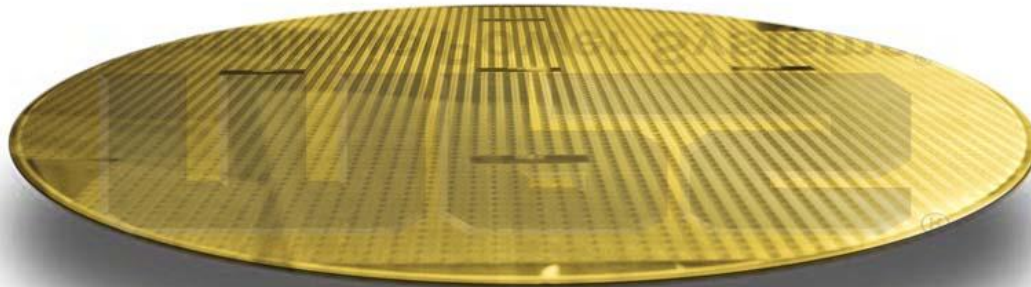

RFI – Xilinx ZU7EV

10/14/2016



ZU7EV Automotive ADAS Solution – MPS power solution

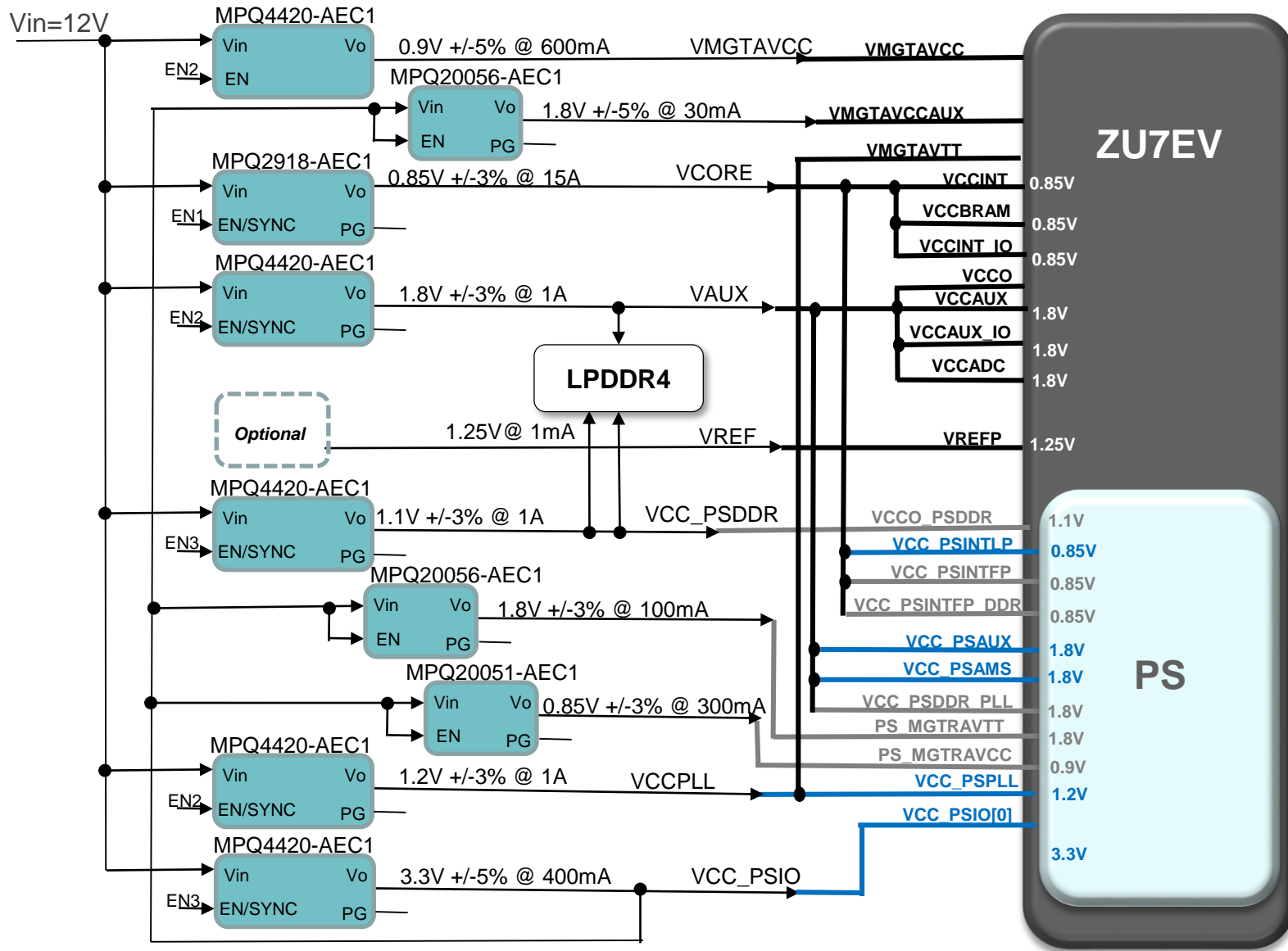



MPS Design specifications

ZU7EV								Sequence						
Rail#	Vin (V)	Rail	MPS part# (Iout max)	Vout (V)	Spec tolerance	Load (A)	POWER (W)	Up	Dwn	Efficiency (%)	Footprint	AC Ripple	AC Transient	DC Error
2	12	Vcore (Includes subrails)	MPQ2918 (15A)	0.85	+/-3%	15.000	12.750	1	4	86%	QFN-20 (3mmx4mm)	+/-1.75%	+/-5%	+/-1.5%
3	12	Vaux (Includes subrails)	MPQ4420 (2A)	1.80	+/-3%	1.000	1.800	2	3	86%	TSOT23-8 (3mmx3mm)	+/-0.28%	+/-1.9%	+/-1.5%
4	3.3	Vps_mgtravcc	MPQ20051 (1A)	0.85	+/-3%	0.300	0.255	3	2		QFN-8 (3mmx3mm)	PSRR=63dB @10kHz		+/-3.0%
5	3.3	Vps_mgtravtt	MPQ20056 (0.25A)	1.80	+/-3%	0.100	0.180	3	2		TSOT23-5 (3mmx3mm) or QFN-8 (2mmx3mm)	PSRR=63dB @10kHz		+/-3.0%
6	12	Vccpspll, Vmgtavtt	MPQ4420 (2A)	1.20	+/-3%	1.000	1.200	2	3	88%	TSOT23-8 (3mmx3mm)	+/-0.4%	+/-2.9%	+/-1.5%
7	12	Vcc_psis	MPQ4420 (2A)	3.30	+/-5%	0.400	1.320	3	2	91%	TSOT23-8 (3mmx3mm)	+/-0.15%	+/-1%	+/-1.5%
8	12	Vcco_psddr	MPQ4420 (2A)	1.10	+/-3%	1.000	1.100	3	2	87%	TSOT23-8 (3mmx3mm)	+/-0.45%	+/-3%	+/-1.5%
9	12	Vmgtavcc	MPQ4420 (2A)	0.90	+/-3%	0.600	0.540	2	3	85%	TSOT23-8 (3mmx3mm)	+/-0.56%	+/-3.9%	+/-1.5%
10	12	Vmgtavccaux	MPQ20056 (0.25A)	1.80	+/-3%	0.030	0.054	3	2		TSOT23-5 (3mmx3mm) or QFN-8 (2mmx3mm)	PSRR=63dB @10kHz		+/-3.0%
11	12	Vref	n/a	1.25	0.20%	0.001	0.001							

Schematics (Typical)

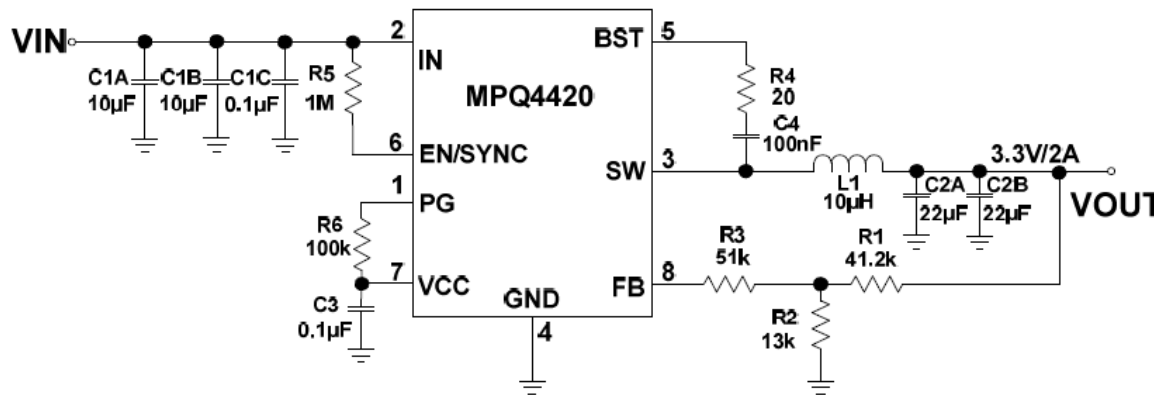

Layout guidelines

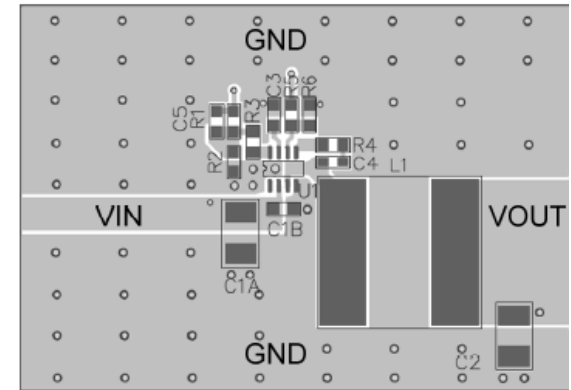

Top Layer

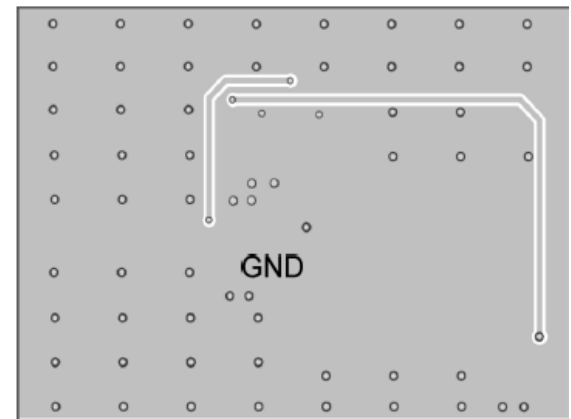

Bottom Layer

- **For Rails:**
 - VAUX, VCCPSPLL, VMGTAVTT, VCCPSIO, VCCOPSDDR, VMGYAVCC
- **External Components: 9**
- **Total PCB : 7 x 10 mm (double layer PCB)**

Schematics (Typical)

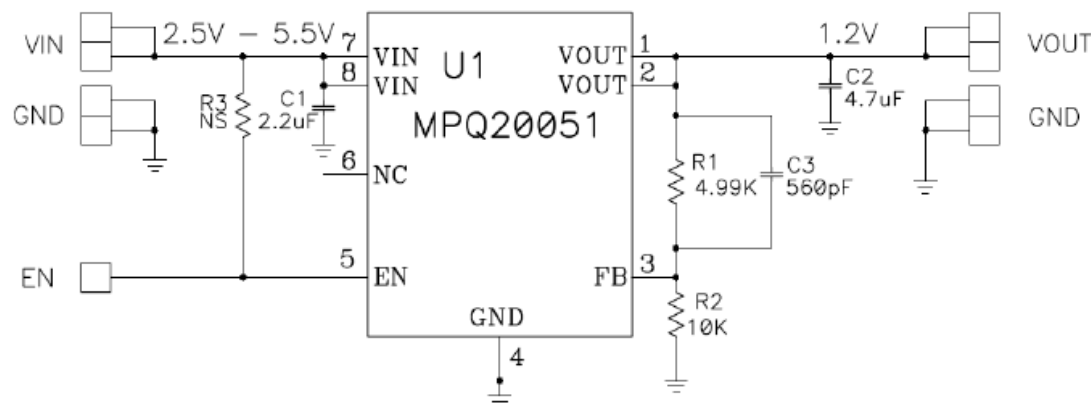

- **For Rails:**
 - VPSMGTRAVCC
- **External Components: 6**
- **Total PCB : 6x6 mm (single layer PCB)**

Layout guidelines

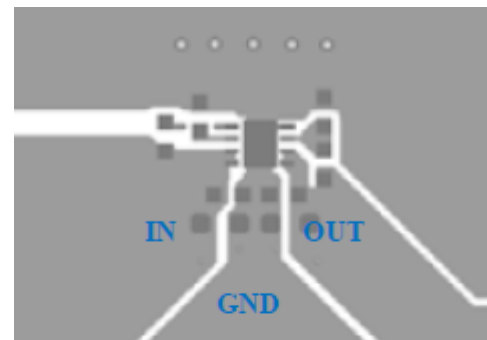

Top Layer

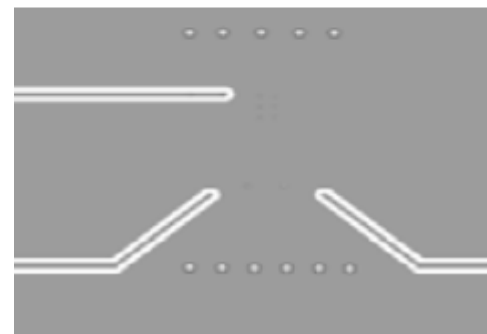

Bottom Layer

Schematics (Typical)

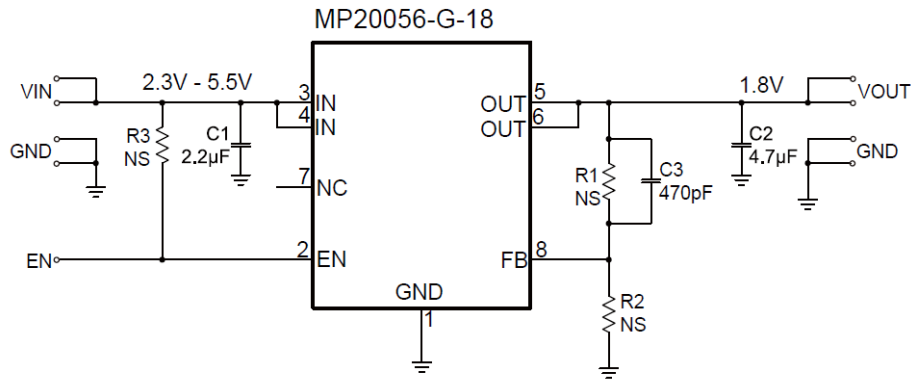

Layout guidelines



- **For Rails:**
- **VPSMGTRAVTT, VMGTAVCCAUX**
- **External Components: 6**
- **Total PCB : 6x6 mm (single layer PCB)**

Schematics (Typical)

Layout guidelines

TYPICAL APPLICATION CIRCUITS

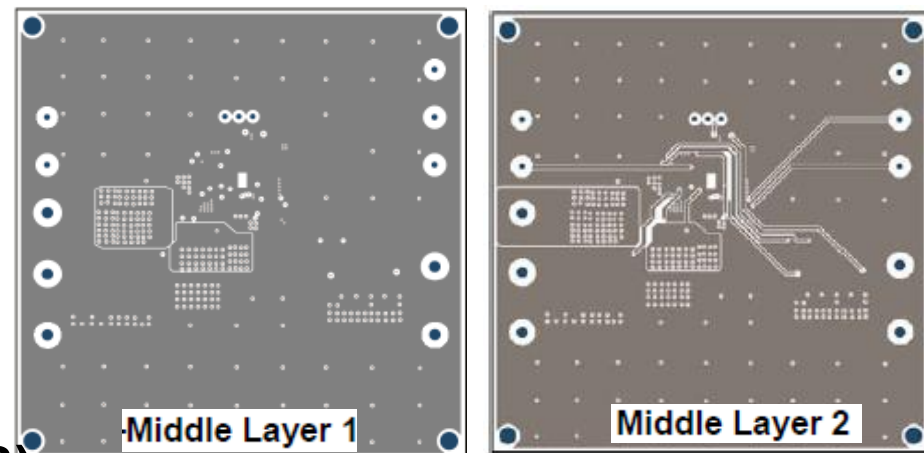
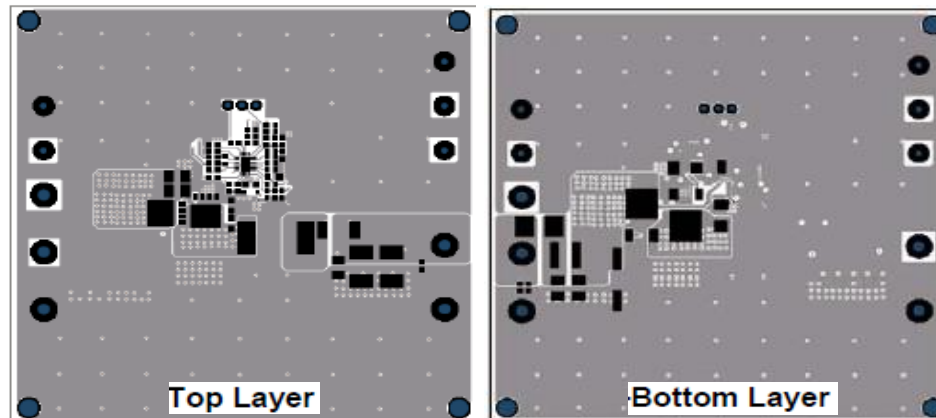
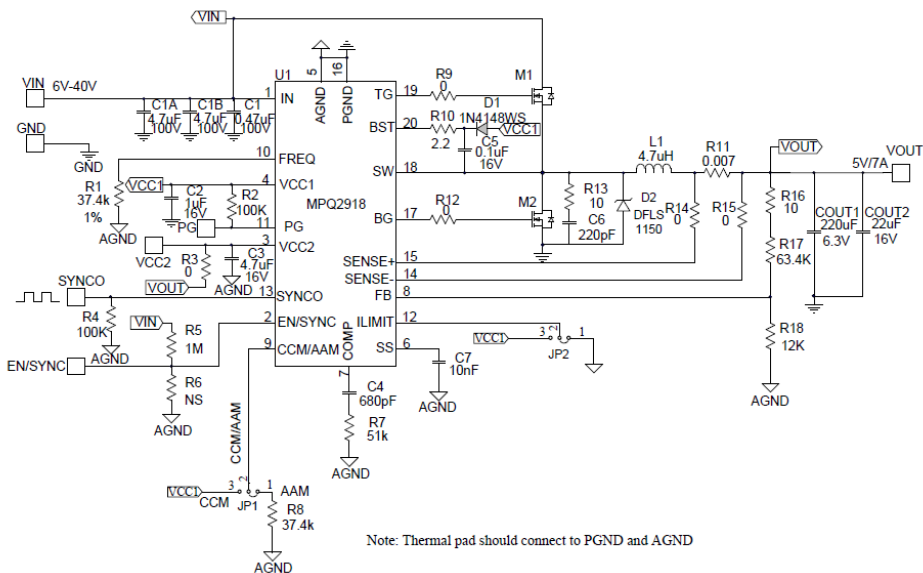

- For Rail:
- VCORE
- External Components: 26
- Total PCB : 20x16 mm (4-layer PCB)

- MPQ4420
 - AEC-Q100 Grade1
 - 36V Input Transient Tolerance
 - High-Efficiency Synchronous Mode
 - Over-current protection and thermal shut down
- MPQ20051 and MPQ20056
 - AEC-Q100 Grade1
 - Low noise, high PSRR
 - Current Limiting and Thermal Protection
- MPQ2918
 - AEC-Q100 Grade1
 - Synchronous step-down controller (up to 40V)
 - Advanced Asynchronous Mode (AAM) for optimized light-load efficiency
 - Over-voltage protection, Over-current protection, and thermal shutdown

Thank you

For additional information please contact

MPS Reference Design Team

at referencedesign@monolithicpower.com

- For general information

<http://www.monolithicpower.com>