

## Introduction

The rated current is a typical parameter for [DC/DC converters](#), and the maximum possible ambient temperature ( $T_A$ ) depends on the PCB size and the IC's thermal resistance. In this article, an automotive expert will examine the thermal behavior of MPS's [MPQ4326-AEC1](#) compared to a traditional 6A device on a small, 2-layer PCB (60mmx40mm).

## Using a 2-Layer Layout

The planned production costs and the PCB size determine the required number of layers, typically two layers. In a 2-layer automotive PCB design, the component placement in DC switching power supplies requires careful consideration to meet EMC and thermal specifications.

## The Method

This article tests the closely matching 2-layer layouts of the MPQ4326-AEC1 and a traditional device rated for 6A (see Figure 1). While each layout has unique component positions, the matching placements for the polygons and vias enable a comparison of the differences between the thermal and efficiency performances of these layouts (see Figure 2 and Figure 3).

Figure 1 shows the typical application schematic for the MPQ4326-AEC1, which closely matches a traditional 6A device.

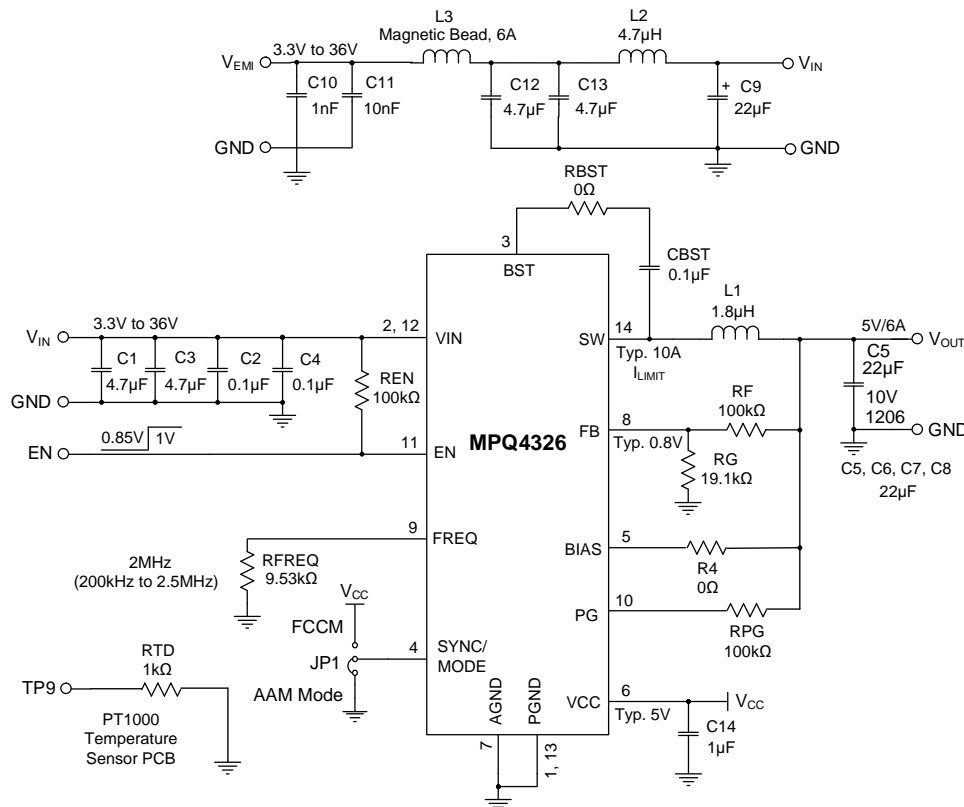

**Figure 1: MPQ4326-AEC1 Typical Application Schematic**

Both ICs use the same external component package sizes and layout, enabling a true 1:1 comparison for efficiency and thermal performances. Some differing IC-specific values include feedback, the switching frequency resistor, and pinout details.

Figure 2 shows the PCB component placement for the MPQ43262-AEC1.

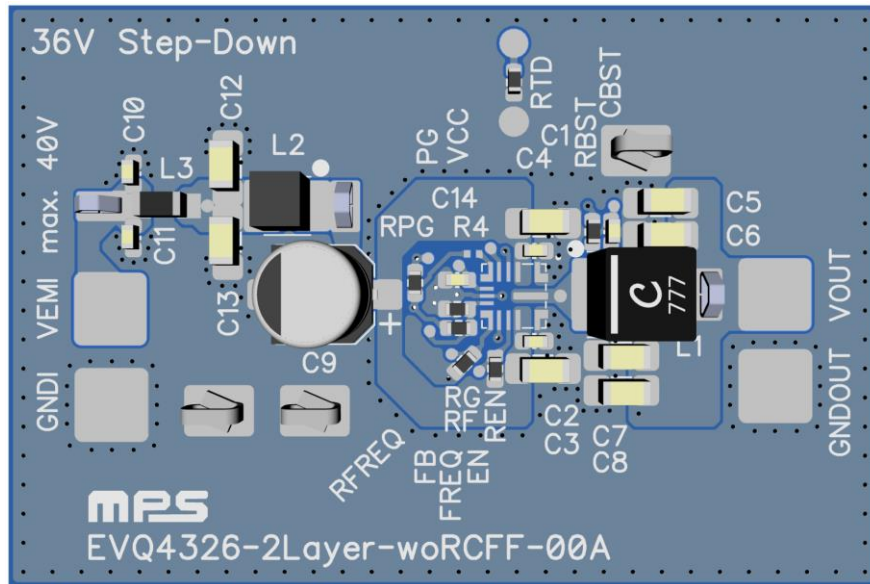

Figure 2: MPQ4326-AEC1 2-Layer PCB (60mmx40mm) Component Placement

Figure 3 shows the PCB component placement for a traditional 6A device.

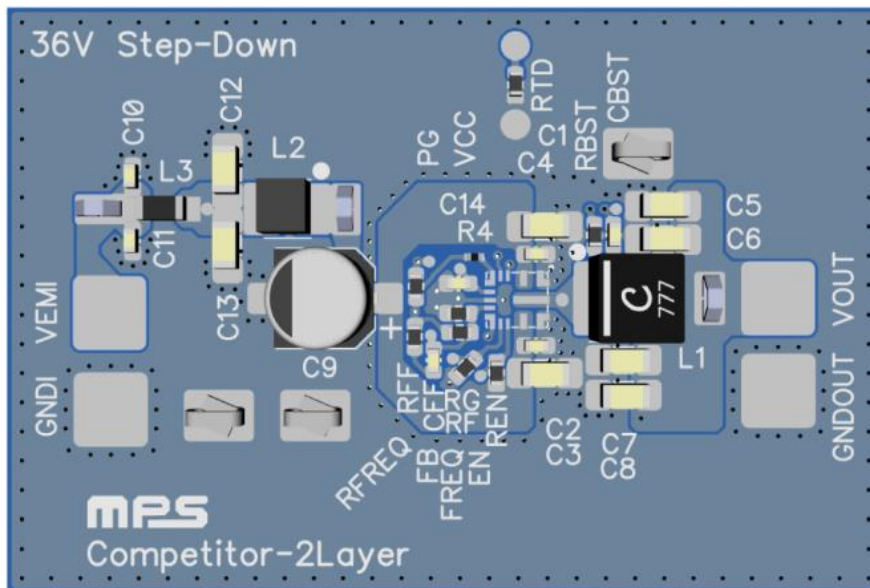

Figure 3: Traditional 6A Device 2-Layer PCB (60mmx40mm) Component Placement

The layout on both PCBs has a common GND plane for the bottom layer as well as a 35µm copper thickness with 1.55mm between the layers on standard FR-4 epoxy. The optional platinum resistance temperature detector (RTD) can measure the PCB temperature.

### Efficiency Measurement

Efficiency is defined as a quotient of the electrical power from the output power ( $P_{OUT}$ ) to input power ( $P_{IN}$ ) of a DC/DC converter. Efficiency is determined by device-specific parameters, application-specific parameters, and PCB-specific parameters, which are described in more detail below:

#### Device-Specific Parameters

- Channel on resistance ( $R_{DS(ON)}$ ) of the high-side and low-side MOSFETs (HS-FET and LS-FET, respectively)
- Electrical resistance of the mechanical contact between the silicon die and the pads
- Rising and falling time that determines how quickly the MOSFETs can be switched on and off
- Power consumption of internal circuitry (e.g. gate driver and logic)
- Junction temperature ( $T_J$ )

#### Application-Specific Parameters

- Input voltage ( $V_{IN}$ ) and output voltage ( $V_{OUT}$ )
- Switching frequency ( $f_{SW}$ )
- Load current ( $I_{LOAD}$ )
- Convection and ambient temperature ( $T_{AIR}$ )

#### PCB-Specific Parameters

- Layout traces, polygons, vias, and switching inductance size produce heatsink, which impacts  $T_J$
- Power loss of the switching inductance ( $P_{IND}$ ), where the common efficiency measurement method considers  $P_{IND}$  as an additional loss of the DC/DC converter

For a proper 1:1 efficiency comparison of the two DC/DC converters, the application and PCB parameters must be the same. Figure 4 shows a comparison of the two PCBs.

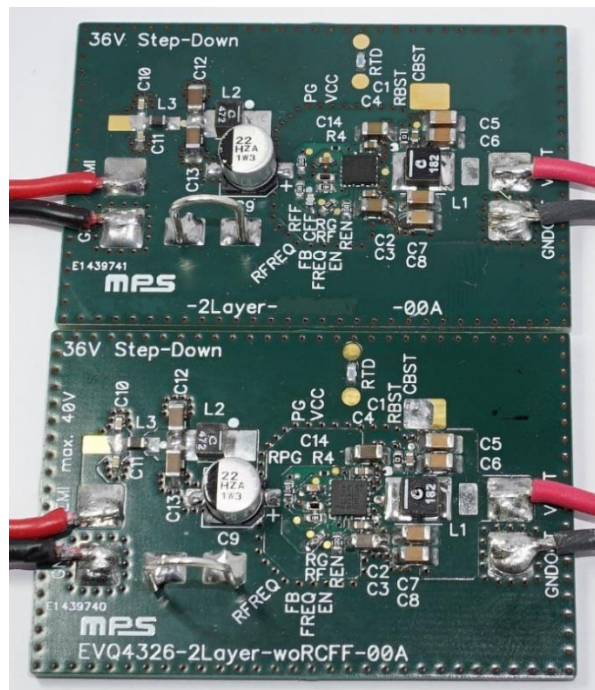

Figure 4: Comparison of 2-Layer PCBs for the MPQ4326-AEC1 and a Traditional 6A Device

## Test Set-Up

Figure 5 shows the set-up to measure the efficiency and the thermal images, where the same power supply drives both PCBs with the same length of power and load cables. Efficiency is measured using four-wire technology for current and voltage. The measuring points are on the electrolytic capacitor for  $V_{IN}$  and on the output MLCCs for  $V_{OUT}$ .



**Figure 5: Test Set-Up for Efficiency and Infrared Thermal Images**

Each PCB can be loaded separately with an adjustable constant current. The IR thermal camera records the temperature profile of both PCBs simultaneously. The PCBs operate at the same conditions with matching surfaces, cables, and air convection, resulting in equal heat dissipation to the ambient temperature.

The MPQ4326-AEC1 comes in a QFN-14 (4mmx4mm) package that is rated for  $I_{LOAD} = 6A$  and a junction-to-ambient thermal resistance,  $\theta_{JA} = 46.7^{\circ}C/W$  on a JE51-7 thermal test PCB. The traditional 6A device comes in a QFN-14 (3.5mmx4mm) package that is rated for  $I_{LOAD} = 6A$  and  $\theta_{JA} > 46.7^{\circ}C/W$  on a JE51-7 thermal test PCB.

$\theta_{JA}$  allows for a 1:1 heat flow comparison from the die temperature to the ambient temperature when soldered on a JEDEC JE51-7 test PCB. A smaller  $\theta_{JA}$  enables improved heat flow from the IC package on the PCB to the ambient air temperature.

**Comparison of Efficiency Curves**

Figure 6 shows the efficiency and total power loss curves for the MPQ4326-AEC1.  $V_{IN}$  is 8V for the orange line, 12V for the red line, 18V for the green line, and 26V for the blue line.

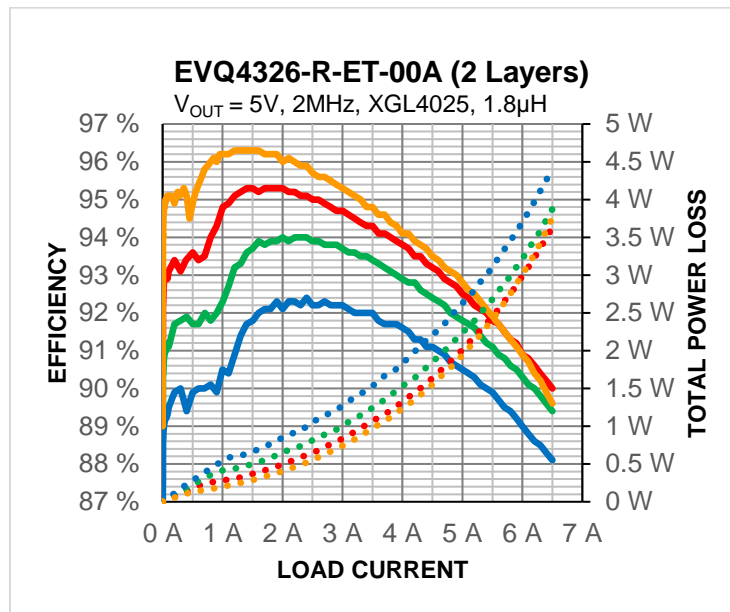

**Figure 6: MPQ4326-AEC1 Efficiency and Total Power Loss on a 2-Layer PCB**

Figure 7 shows the efficiency and total power loss curves for the traditional 6A device. Similar to Figure 6,  $V_{IN}$  is 8V for the orange line, 12V for the red line, 18V for the green line, and 26V for the blue line.

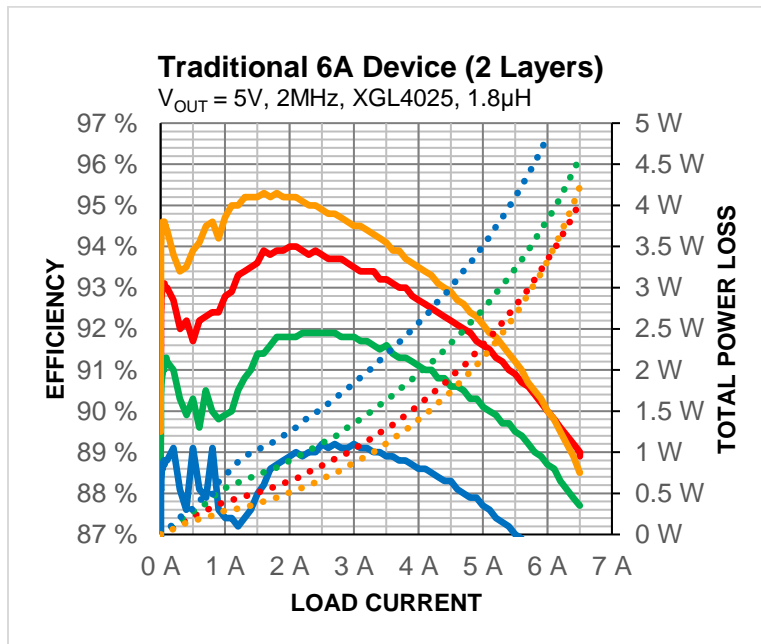
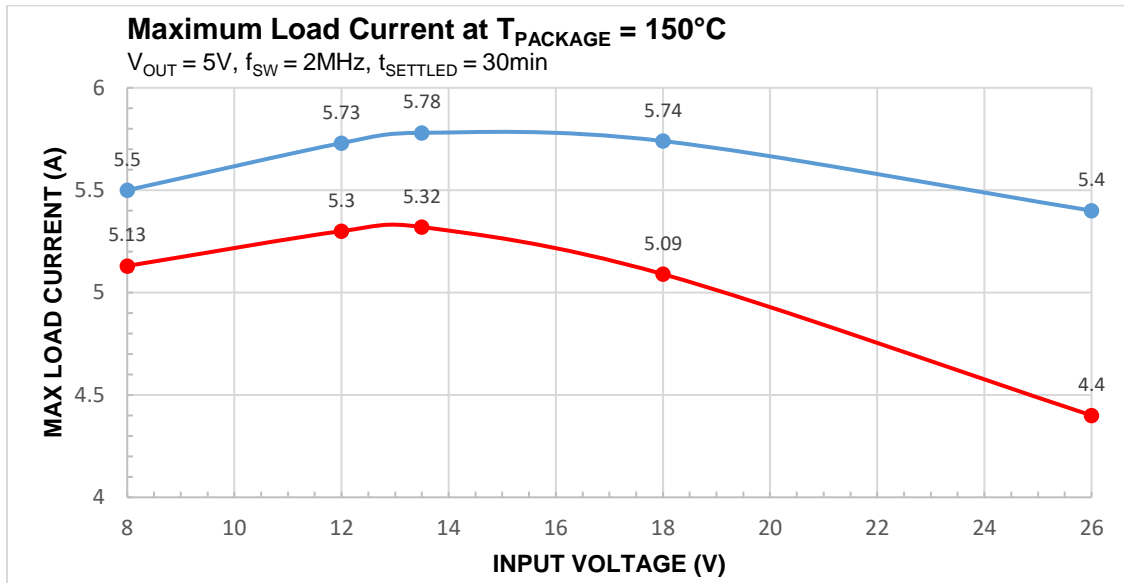

**Figure 7: Traditional 6A Device Efficiency and Total Power Loss on a 2-Layer PCB**

Under the same applications and PCB conditions, the MPQ4326-AEC1 achieves higher efficiency and lower total power loss. Thus, the advantage of the MPQ4326-AEC1 at high load currents is clear.

**Maximum Load Current vs. Input Voltage at  $T_{PACKAGE} = 150^{\circ}C$**

Figure 8 shows the maximum achievable  $I_{LOAD}$  ( $I_{LOAD\_MAX}$ ) when the package temperature at the top of the IC ( $T_{PACKAGE}$ ) remains constant at  $150^{\circ}C$  while sweeping  $V_{IN}$ . The blue line represents the MPQ4326-AEC1, and the red line represents the traditional 6A device.

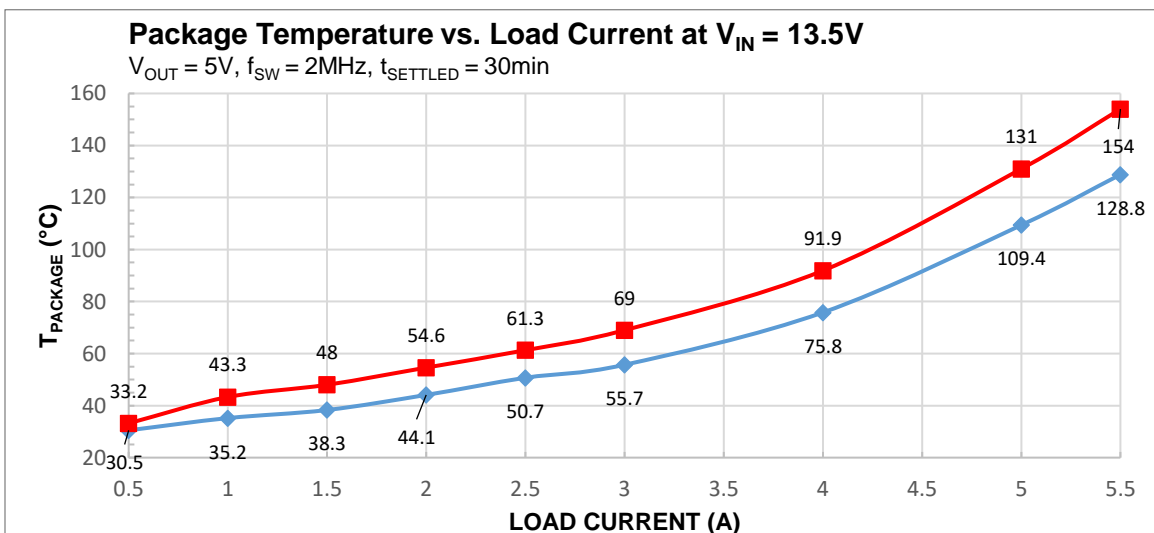

**Figure 8: Maximum Load Current at  $T_{PACKAGE} = 150^{\circ}C$**

Compared to the traditional 6A device, the MPQ4326-AEC1 supports up to 1A of additional  $I_{LOAD}$  under the same conditions and  $T_{PACKAGE}$ .

**Package Temperature vs. Load Current at  $V_{IN} = 13.5V$**

Figure 9 shows  $T_{PACKAGE}$  when sweeping  $I_{LOAD}$ , where the blue line represents the MPQ4326-AEC1, and the red line represents the traditional 6A device.

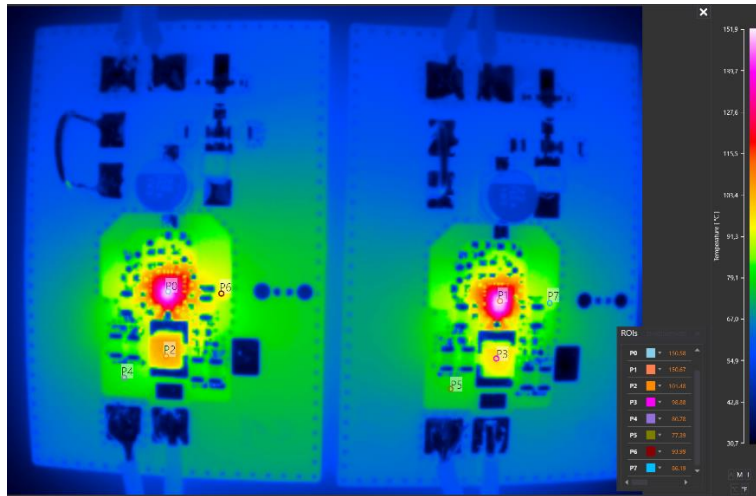

**Figure 9: Package Temperature vs. Load Current at  $V_{IN} = 13.5V$**

At  $I_{LOAD} = 5.5A$ , the MPQ4326-AEC1's  $T_J$  is below the traditional 6A device's  $T_J$  by  $25^{\circ}C$ . The advantages of the MPQ4326-AEC1 are significant. Each measurement point is settled for 30 minutes to ensure steady conditions.

**Thermal Image of Maximum Load Current vs. Input Voltage at  $T_{PACKAGE} = 150^{\circ}C$**

Figure 10 shows the infrared images of the two PCBs, which each have a different  $I_{LOAD\_MAX}$  when  $T_{PACKAGE}$  reaches  $150^{\circ}C$ . The thermal images are tested at  $V_{IN} = 26V$ ,  $V_{OUT} = 5V$ ,  $T_{AIR} = 23^{\circ}C$ ,  $f_{SW} = 2MHz$ , and  $t_{SETTLED} = 30min$ .  $I_{LOAD}$  of each PCB is adjusted to its maximum value until  $T_{PACKAGE}$  of both PCBs reaches  $150^{\circ}C$ . The MPQ4326-AEC1 is shown on the left at  $I_{LOAD\_MAX} = 5.4A$  and  $P_{OUT} = 27W$ . The traditional 6A device is shown on the right at  $I_{LOAD\_MAX} = 4.4A$  and  $P_{OUT} = 22W$ .

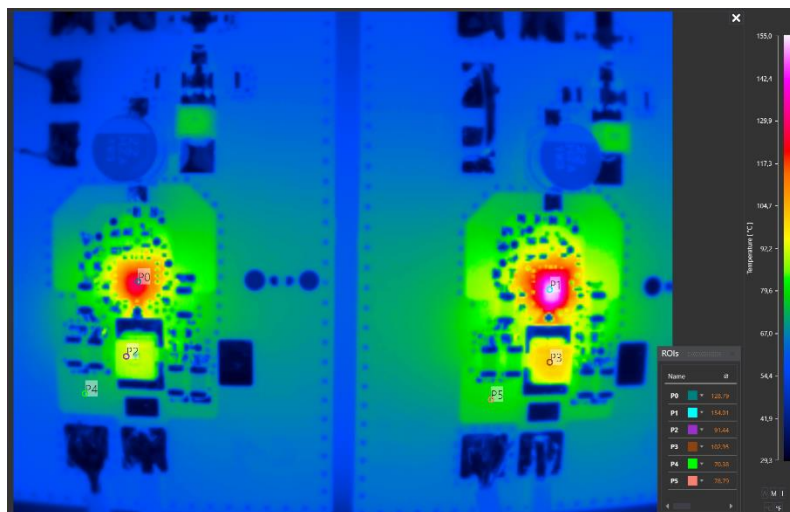

**Figure 10: MPQ4326-AEC1 vs. Traditional 6A Device at  $T_{PACKAGE} = 150^{\circ}C$  and Different  $I_{LOAD\_MAX}$  Values**

Under the same conditions, the MPQ4326-AEC1 can achieve up to 1A of additional output current. The MPQ4326-AEC1’s PCB (left) has a slightly higher temperature caused by the higher  $P_{OUT}$  and higher input currents.  $T_{PACKAGE}$  is the same for both PCBs, indicating the MPQ4326-AEC1 package’s improved efficiency and lower  $\theta_{JA}$  from the silicon to the ambient temperature, mainly in the solder pads.

**Thermal Image of Package Temperature vs. Load Current at  $V_{IN} = 13.5V$**

Figure 11 shows the infrared images for  $T_{PACKAGE}$  when sweeping  $I_{LOAD}$ . The thermal images are tested at  $I_{LOAD} = 5.5A$ ,  $P_{OUT} = 27.5W$ ,  $V_{IN} = 13.5V$ ,  $V_{OUT} = 5V$ ,  $T_{AIR} = 23^{\circ}C$ ,  $f_{SW} = 2MHz$ , and  $t_{SETTLED} = 30min$ .  $I_{LOAD}$  increases to its maximum value until  $T_{PACKAGE}$  of one of the PCBs reaches  $150^{\circ}C$ . The MPQ4326-AEC1 is shown on the left at  $T_{PACKAGE} = 129^{\circ}C$ . The traditional 6A device is shown on the right at  $T_{PACKAGE} = 154^{\circ}C$ .



**Figure 11:  $T_{PACKAGE}$  vs.  $I_{LOAD}$  of MPQ4326-AEC1 and Traditional 6A Device**

Under the same conditions, the MPQ4326-AEC1's  $T_{\text{PACKAGE}}$  remains 25°C below the traditional 6A device. Measurement stops at  $I_{\text{LOAD}} = 5.5\text{A}$  as the traditional 6A device's  $T_{\text{PACKAGE}}$  reaches 154°C. This prevents  $T_{\text{PACKAGE}}$  from further increasing and causing thermal shutdown.

### Conclusion

In this article, we made comparative measurements using the [MPQ4326-AEC1](#) and a traditional 6A device, nominally specified for  $I_{\text{LOAD}} = 6\text{A}$ . The specified rated current can be achieved on a small, low-cost PCB with differences in  $T_{\text{PACKAGE}}$  and  $I_{\text{LOAD\_MAX}}$ . Across the efficiency, maximum load current, package temperature, and thermal measurements, the MPQ4326-AEC1 demonstrates key advantages in efficiency and lower total power loss.

The PCB's size and technology must be adjusted when operating at higher  $T_A$  values, as the heat flow of the 2-layer (60mmx40mm) PCB is insufficient. Furthermore, the 1:1 comparative test proves that a 6A DC/DC converter cannot consistently deliver a 6A  $I_{\text{LOAD}}$ , depending on the PCB's heat flow capability, thermal resistance of the package, and efficiency.

MPS products provide specifications for the nominal current. Contact an MPS FAE for more details on optimizing PCBs for application specifications, and explore MPS's wide selection of [switching converters and controllers](#).