

Spread Spectrum to Reduce EMI

Presenter: Christian Kueck

April 6th , 2022

Presenter Intro: Christian Kueck

- Senior FAE supporting automotive Tier-1 customers throughout Germany
- About three decades of experience managing EMI challenges
- Deeply involved in the definition and compliance testing of our leading AEC-Q100 power management solutions
- 6 years at MPS as Power Senior Field Application Engineer
- 22 years at Linear Technology
 - Strategic Marketing Manager for Europe – Product definition and product support for PSU and LED circuits
 - Field Application Engineer
- Additional:
 - Design Engineer, Quality Assurance, Materials Engineer
- Microelectronics. Dipl. Ing., Elektrotechnik University of Dortmund



Today's Agenda

The Motivation

PSU Fixed Frequency Spectrum

Effect of Switching Frequency and Duty Cycle on EMI

What Can Spread Spectrum Accomplish

Effective Methods to Make Spread Spectrum

Frequently Asked Questions About Spread Spectrum

Open Q&A

Motivation

Often results are just a hair or two above the limits. So what can you do?

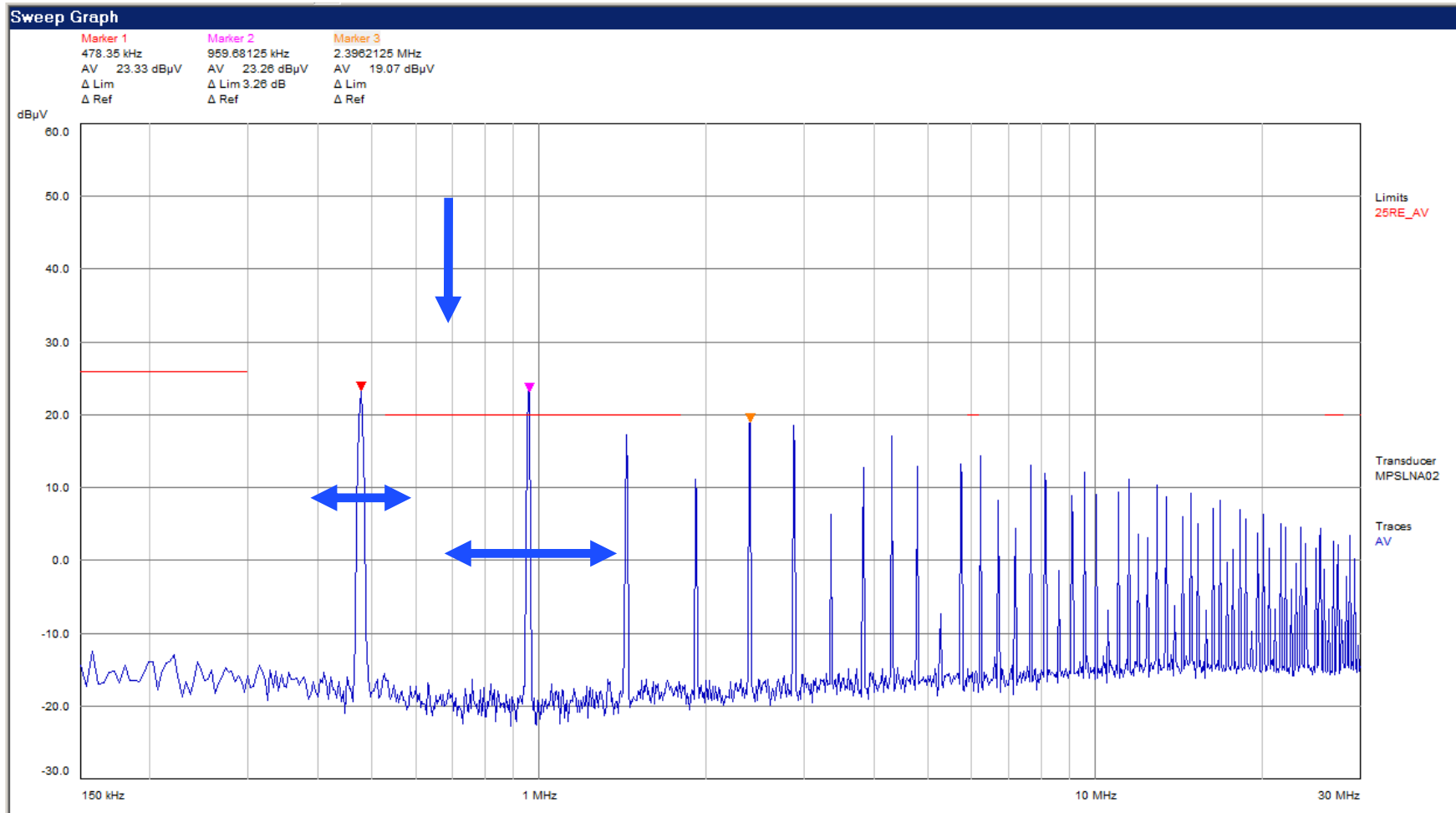

Fixed Frequency PSU Spectrum

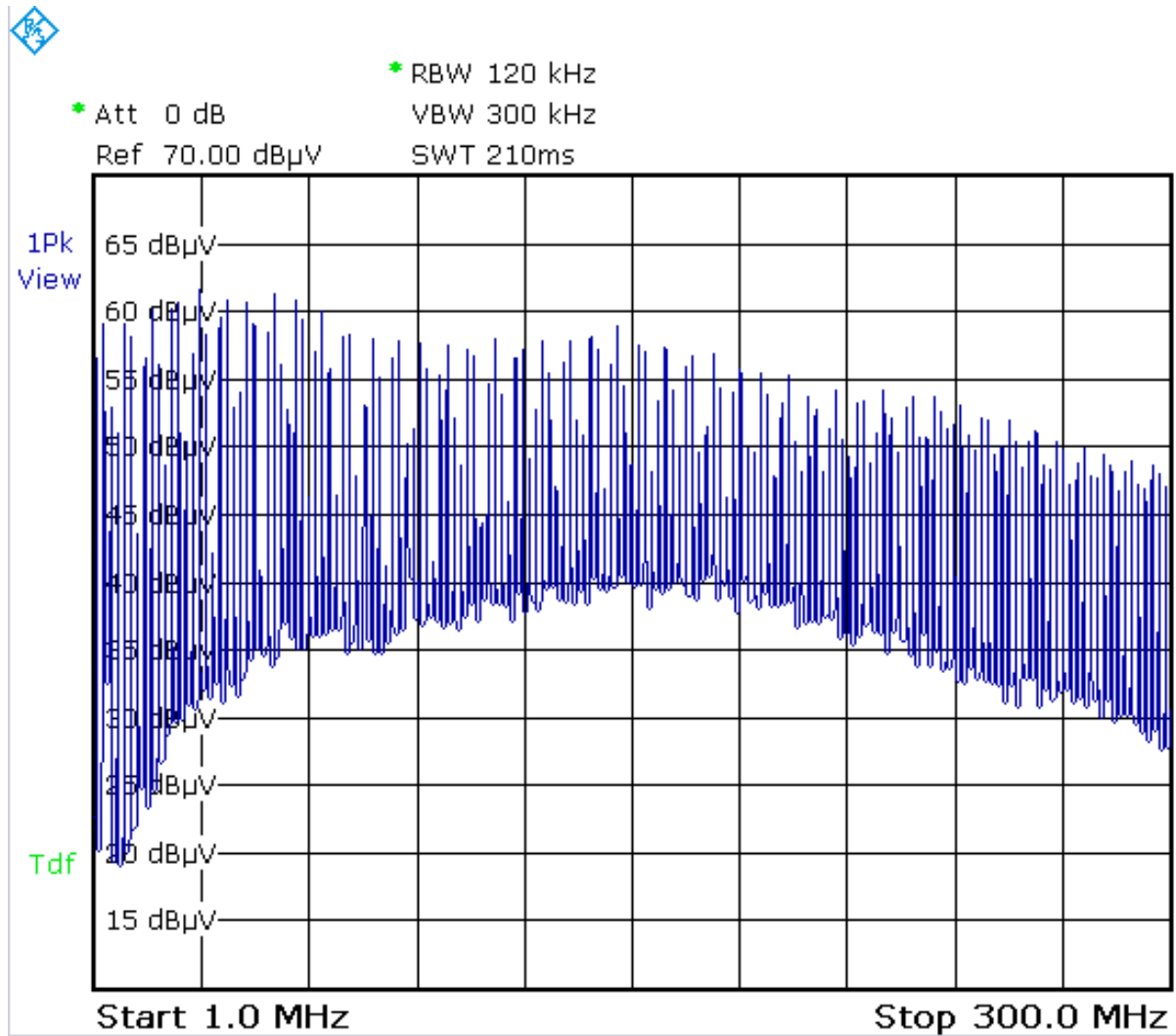

The typical PSU switch excitation source creates a flat periodic “fence” of spurs in the frequency domain, spaced by the switching frequency.

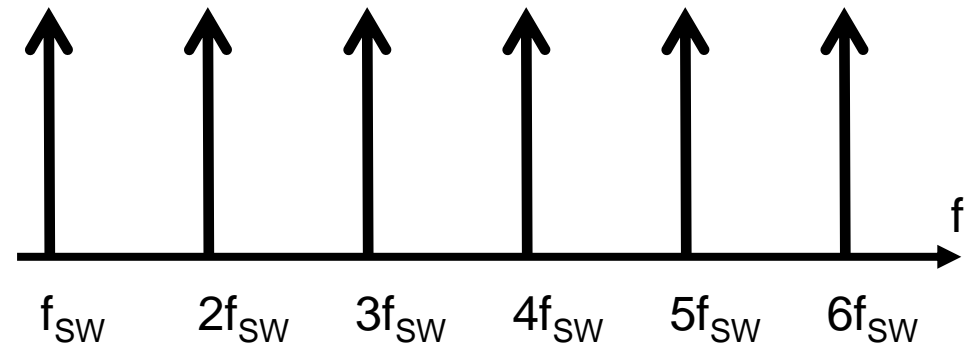

Fixed Frequency PSU Spectrum

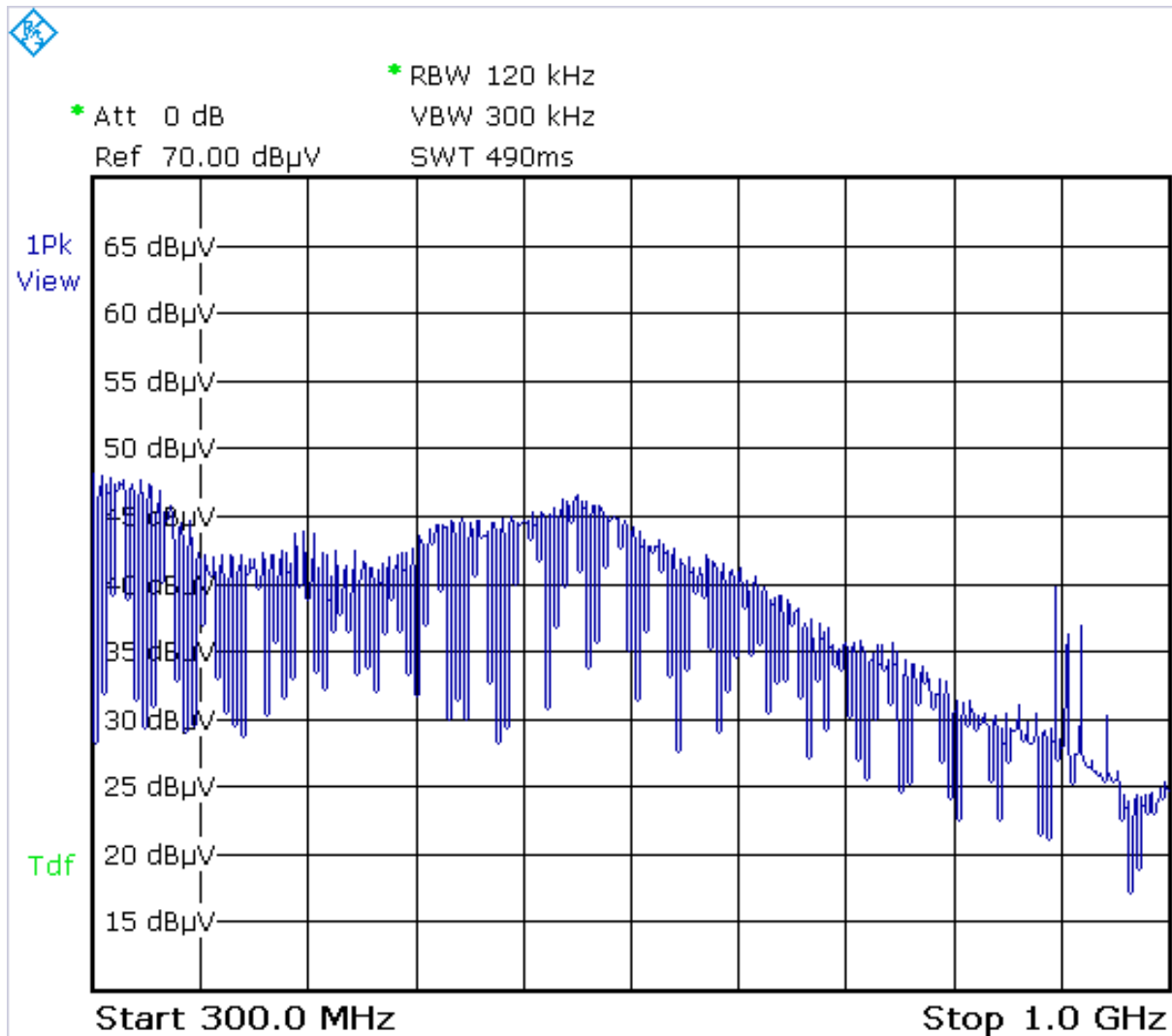

At a certain frequency, it will attenuate like a high order low pass.

For most modern hard switch designs, there should not be much energy left above 500MHz.

PSUs have harmonics into the high triple digits. Spread spectrum on high harmonics is seldom covered in literature.

How Does Duty Cycle Affect the Lower Harmonics? Video

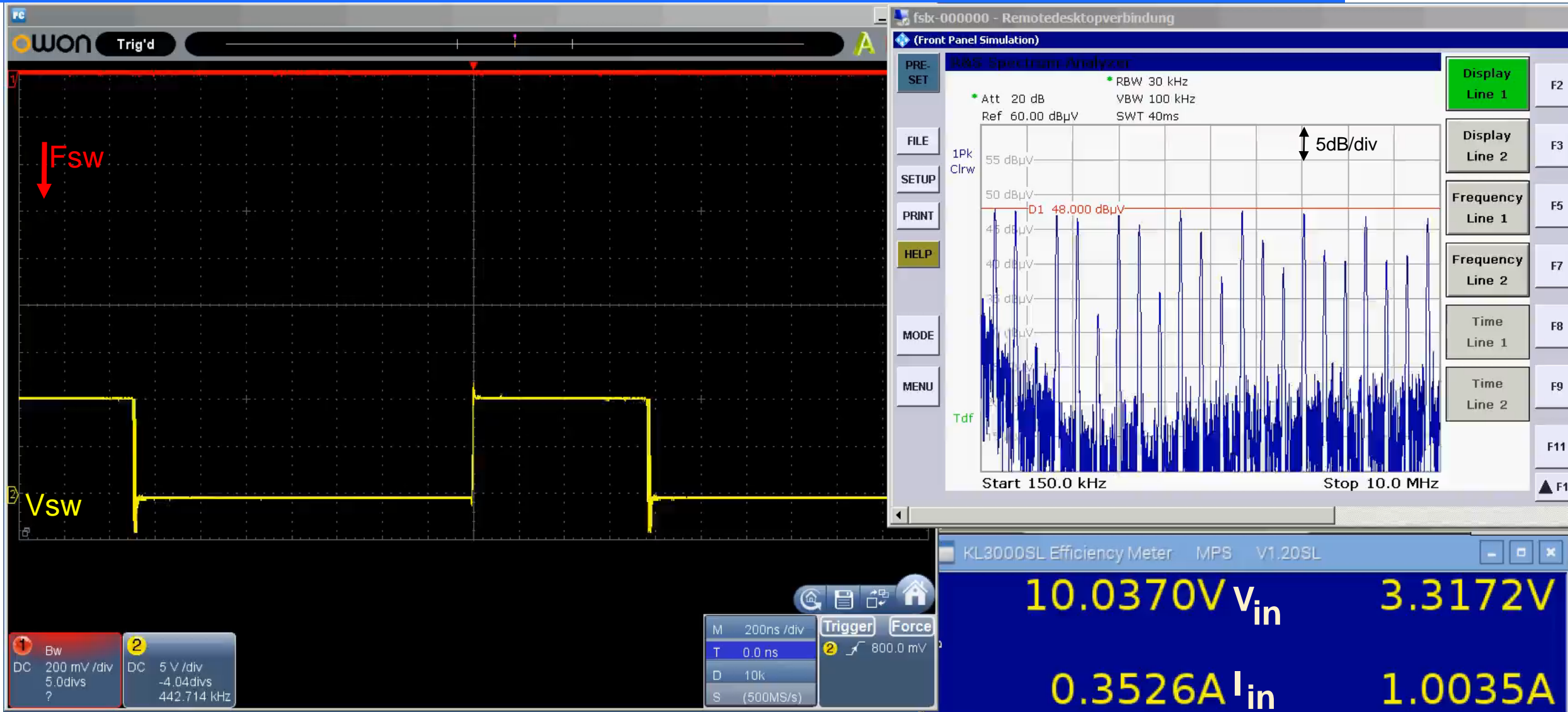

How Does Duty Cycle Affect the Lower Harmonics?

At 50% duty cycle, all even harmonics disappear.

Lower harmonics distribution depends on duty cycle = V_{OUT} / V_{IN} for a buck topology and can be derived by fourier transformation of the switch node waveform

Harmonic energy goes up with input voltage

How Does Switching Frequency Affect the EMI <10MHz? Video

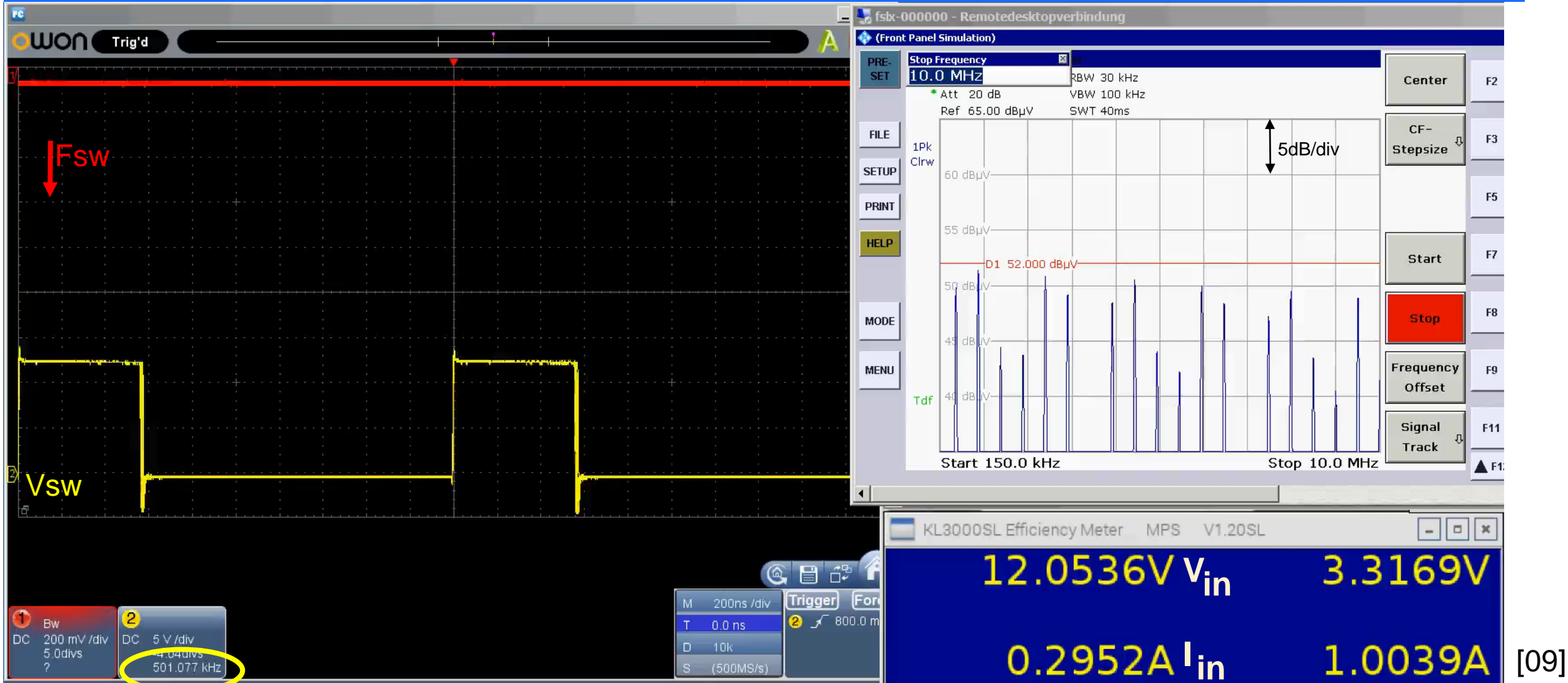

Switching Frequency

How Does Switching Frequency Affect EMI 150kHz-300MHz? Video

500k
1MHz
2MHz

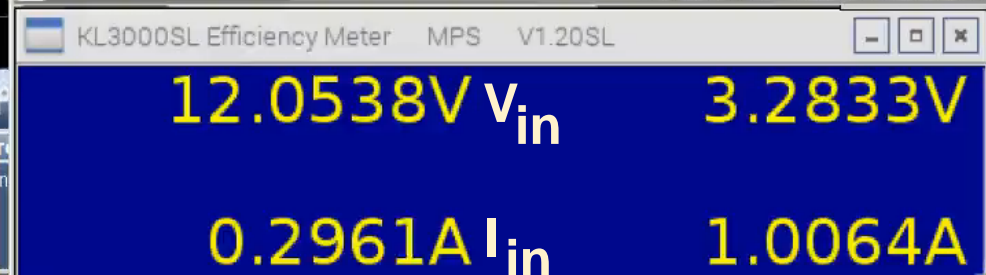
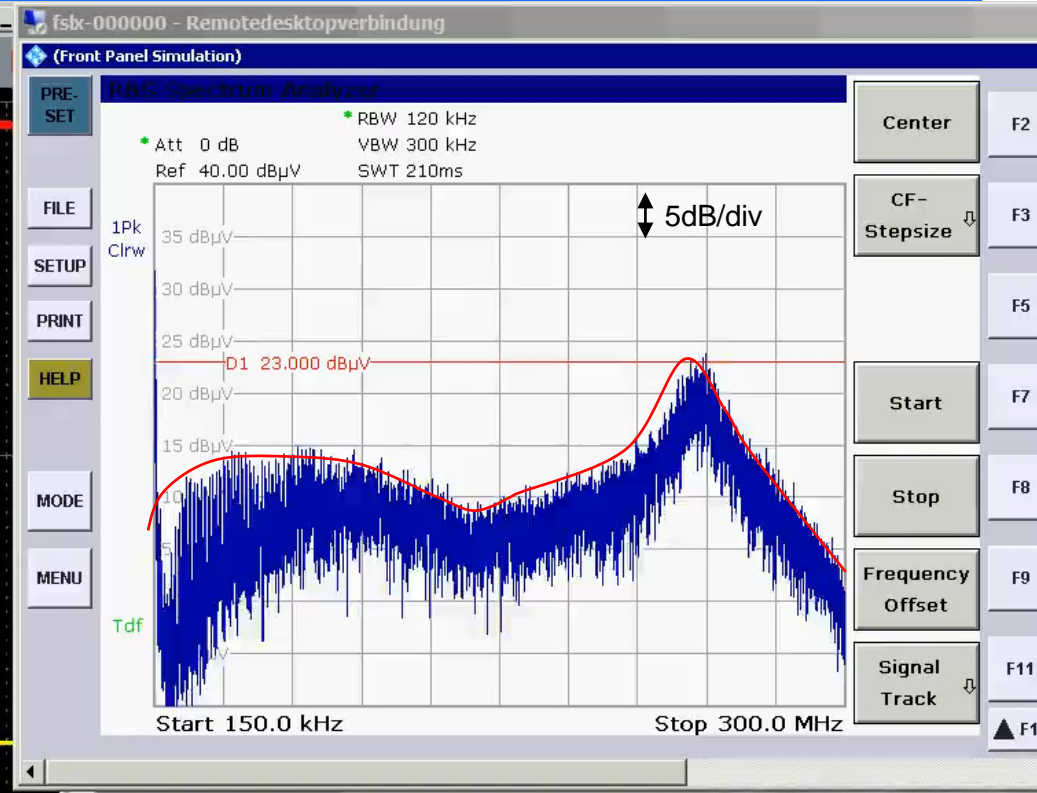
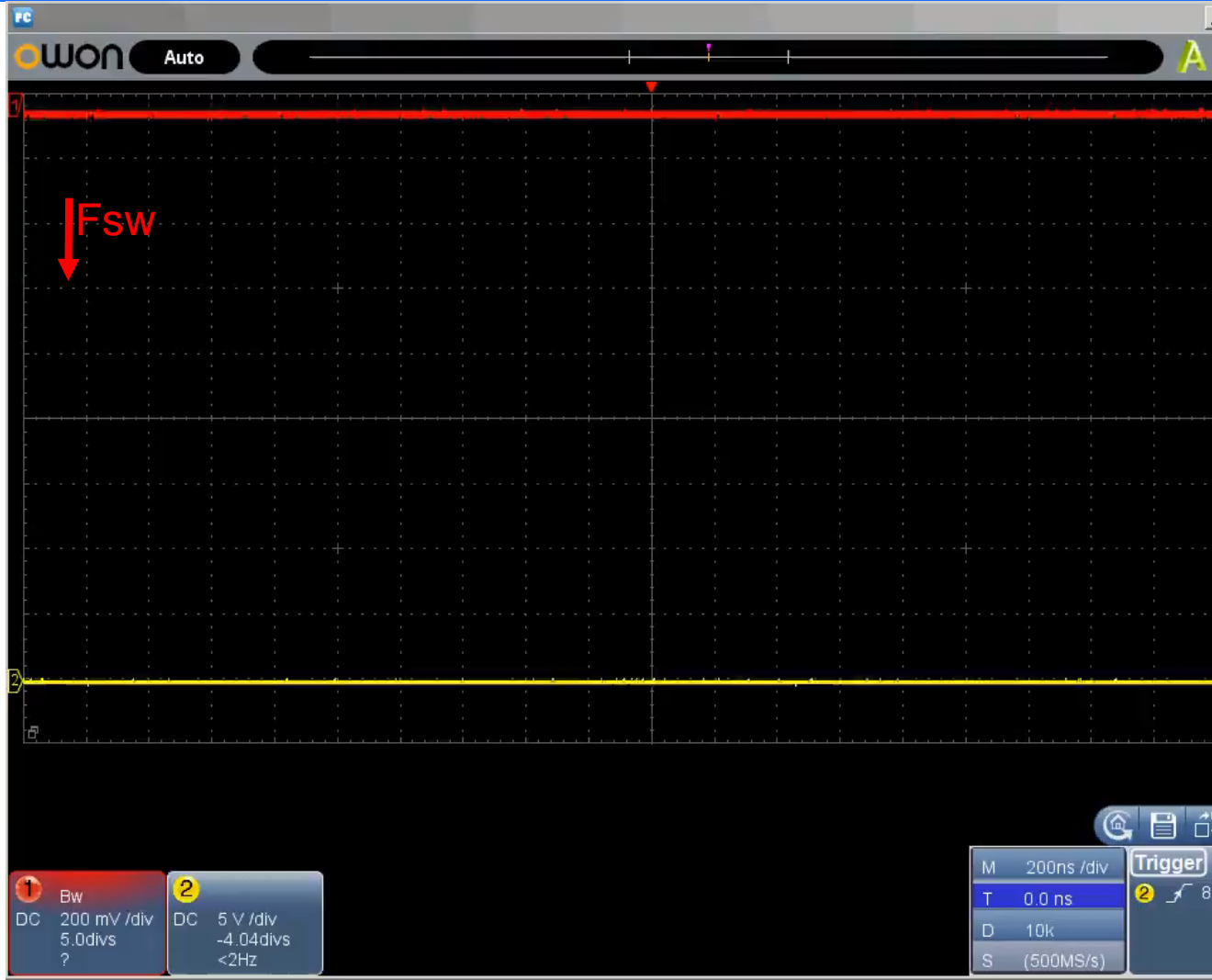

[10]



EMI Receiver According to CISPR 16-1-1

Block Diagram of an EMI Receiver

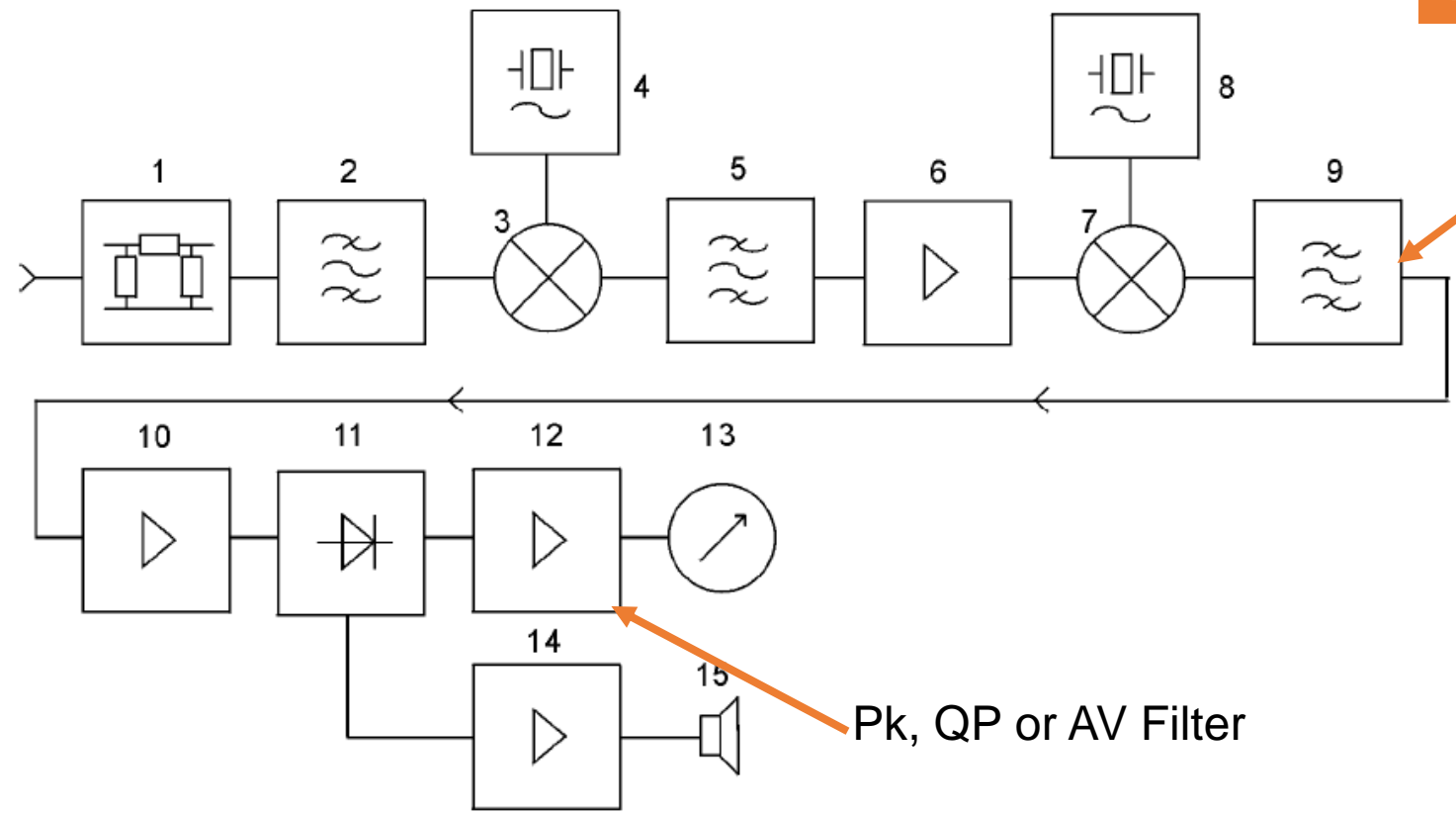

RBW – Resolution Bandwidth Filter
 9 KHz <30MHz
 120 KHz >30MHz

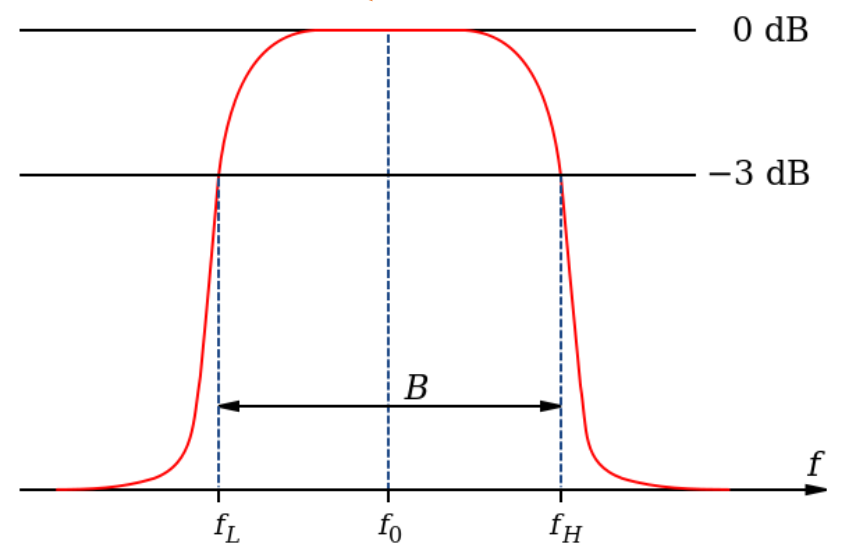

Pk, QP or AV Filter

EMI Receiver Spectral View

The RBW filter moves with constant velocity (frequency change) through the receiver span from Freq start to Freq stop. This is a convolution operation in the frequency domain.

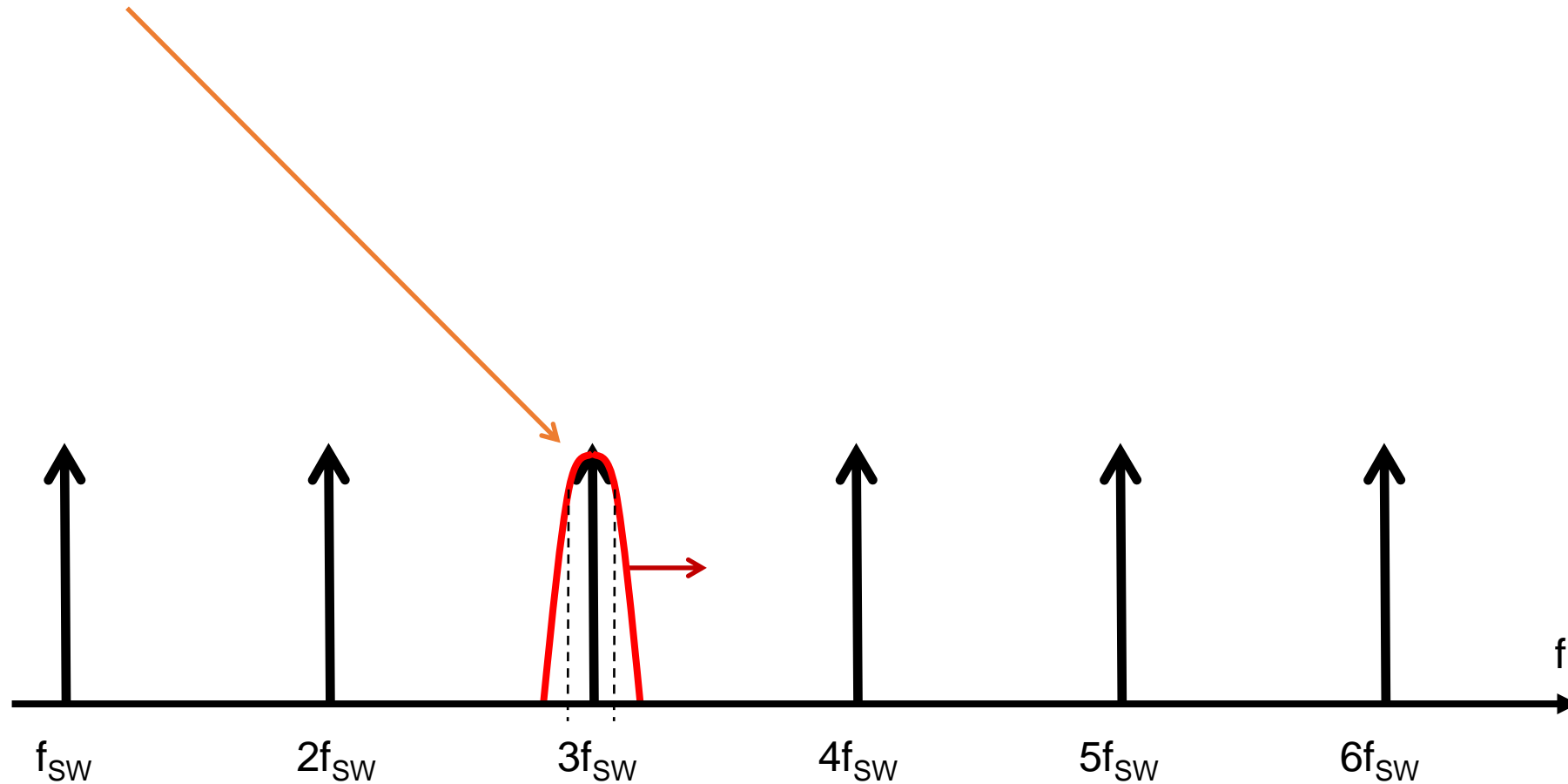

EMI Receiver Spectral View

Area where you can still hide spur energy that the EMI receiver does not see

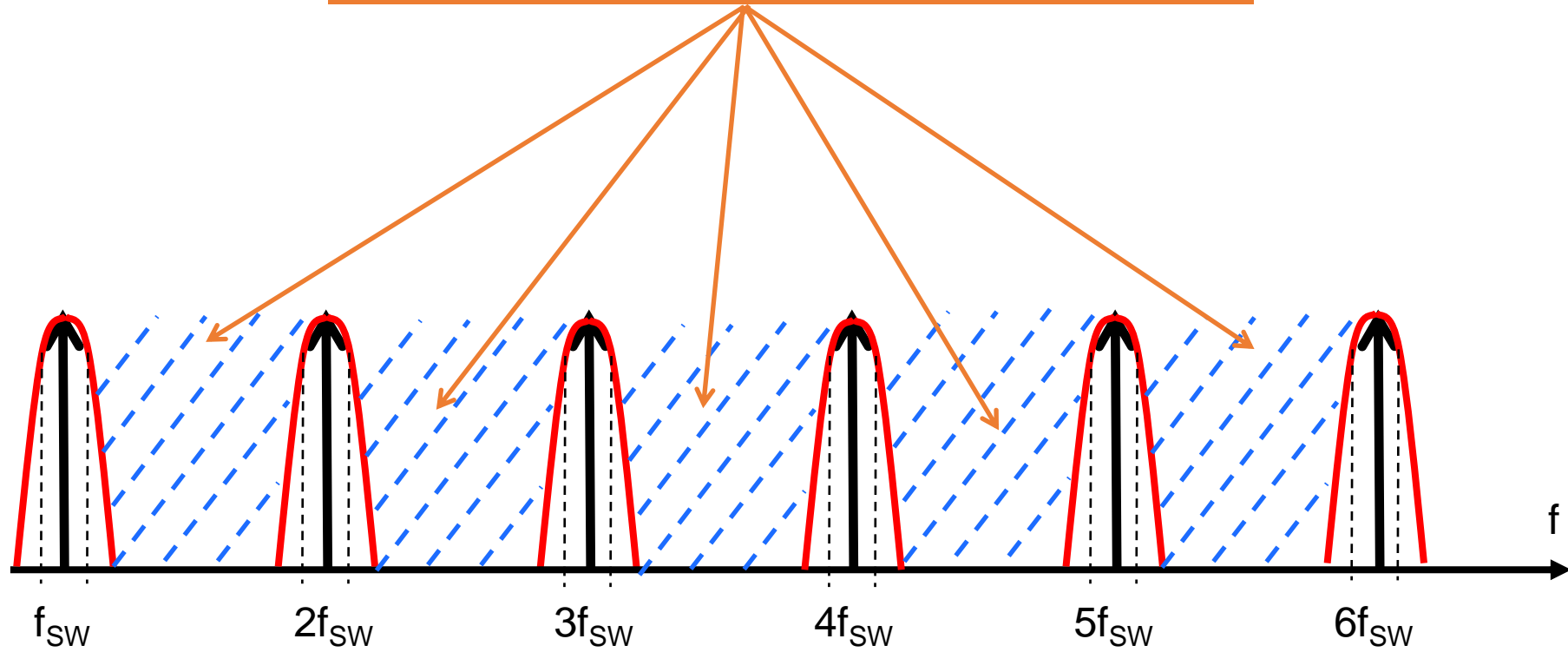

EMI Receiver Spectral View

Ideal would be a white noise like spectrum

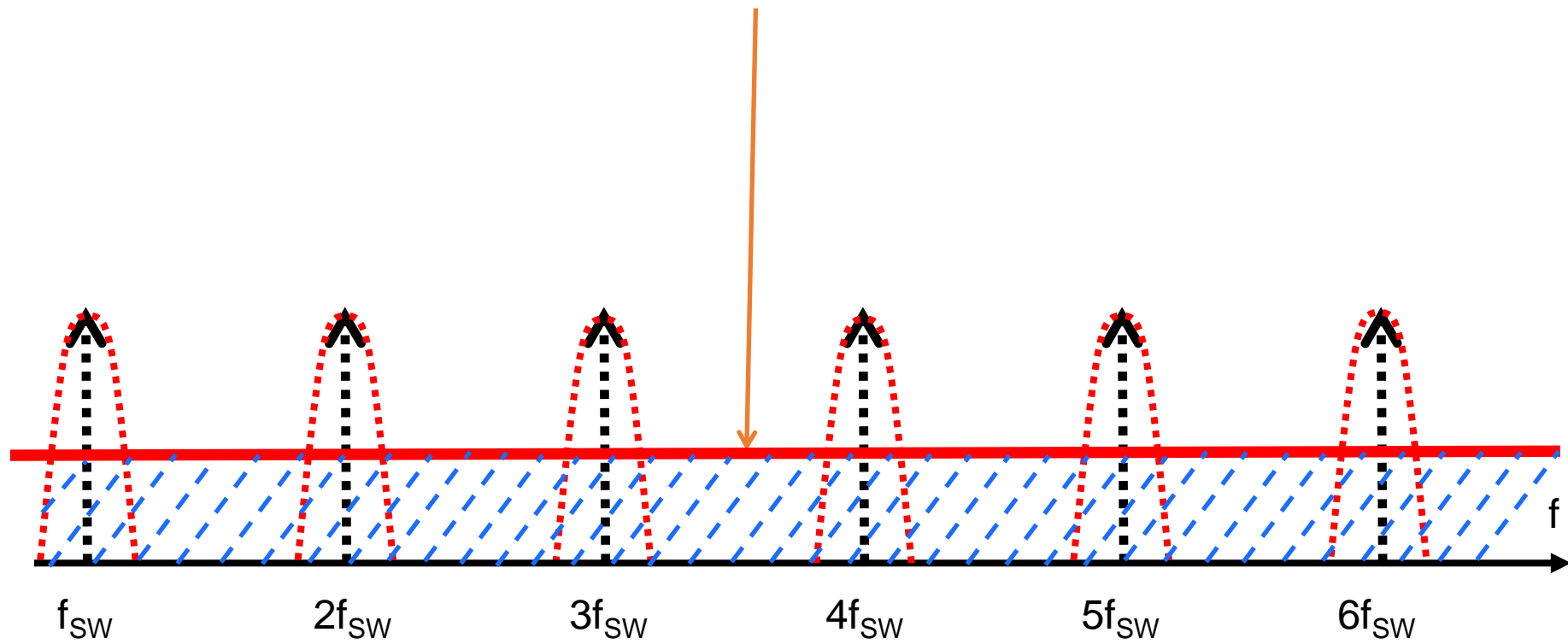

EMI Receiver Spectral View

Optimal Attenuation

$$\text{Attenuation} = 10 * \log_{10} \left(\frac{RBW}{f_{sw}} \right)$$

Lower attenuation >30 MHz

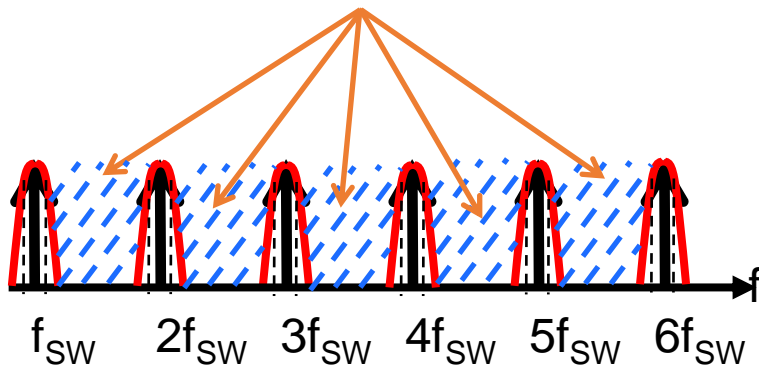

Maximum Achievable Spread Spectrum Attenuation			
	0.15MHz–30MHz	30MHz–1GHz	>1GHz
RBW [kHz]	9	120	1000
f_{sw} [kHz]	[dB]	[dB]	[dB]
100	-10.5	0.0	0.0
200	-13.5	-2.2	0.0
400	-16.5	-5.2	0.0
1000	-20.5	-9.2	0.0
2000	-23.5	-12.2	-3.0
3000	-25.2	-14.0	-4.8
5000	-27.4	-16.2	-7.0
10000	-30.5	-19.2	-10.0
100000	-40.5	-29.2	-20.0

RBW Filter Time Domain View of Spur in the Frequency Domain

If the carrier stays longer than the bandpass impulse response time $\frac{1}{RBW}$ inside the passband, there will be no attenuation through the RBW filter, and you see the spurs' original energy.

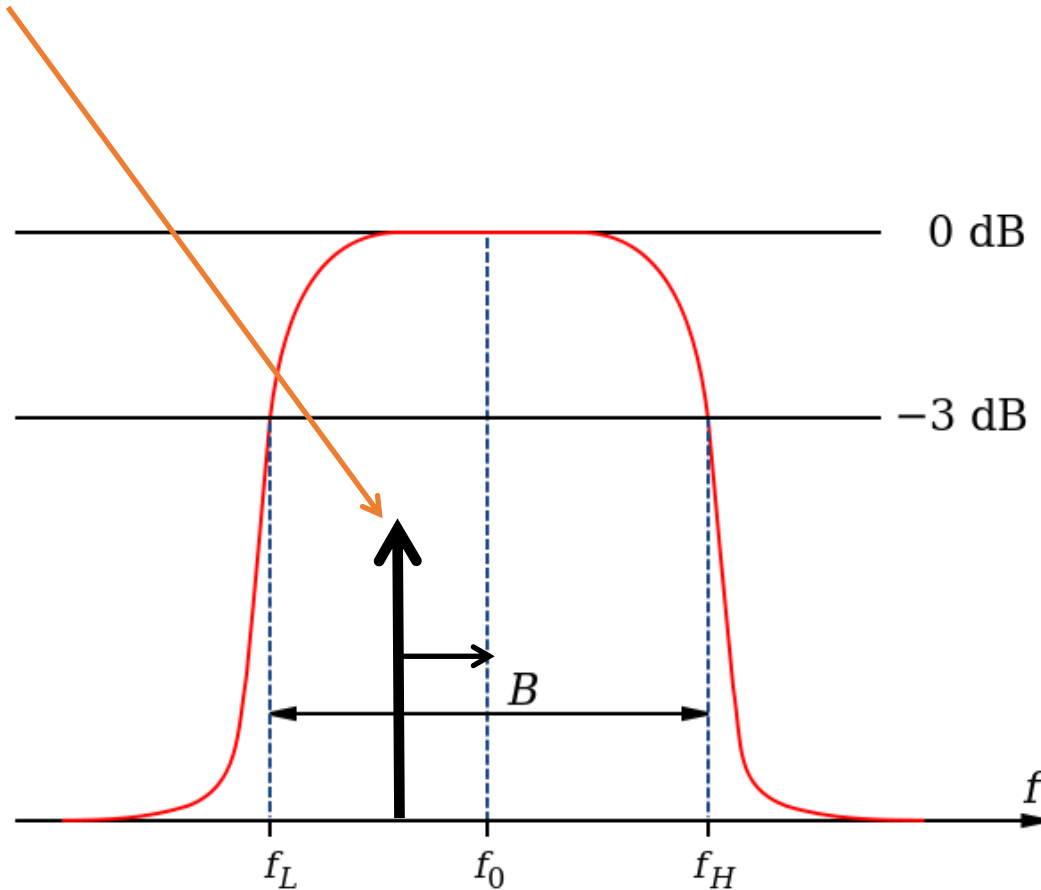

$$\frac{1}{9kHz} = 111\mu s$$

$$\frac{1}{120kHz} = 8.33\mu s$$

RBW Filter Time Domain View of Spur in the Frequency Domain

To get attenuation through spectral movement, one needs to rip with spurs faster through the RBW filter than their time domain impulse response.

The speed at which the frequency changes needs to be faster than:

$$\frac{RBW}{\text{Impulse response time}} = \frac{RBW}{\frac{1}{RBW}} = RBW^2 = a \quad \text{with be measured in } \frac{\text{Hz}}{\text{s}} \text{ or in } \frac{\text{Periods}}{\text{s}^2}$$

According to CISPR16 / 22 / 25, for the bands to get attenuation in PK mode at all the frequency change (speed or sweep) needs to be faster than:

150kHz to 30MHz with RBW = 9kHz > 81MHz/s
30MHz to 1GHz with RBW = 120KHz > 14.4GHz/s
>1GHz with RBW = 1MHz > 1THz/s

FM Modulation Frequency Domain View

Signal needs to be somewhat periodic (can't move constant to infinity).

Constant energy for no additional output ripple => FM = frequency modulation

Modulation frequency (FM)

The repetitive frequency $FM = 1/\text{period}$ where the modulation waveform repeats.

Modulation depth $(\Delta f) = f_{MAX} - f_{MIN}$.

The span or stroke of the modulated signal

Modulation index $h = \frac{\Delta f}{FM}$

Goes linear up with harmonic number

FM Modulation Attenuation

Modulation depth Δf rises linearly with the harmonic number of the spur = $N * \Delta f$

The same applies for the modulation index $h = \frac{N * \Delta f}{f_m}$

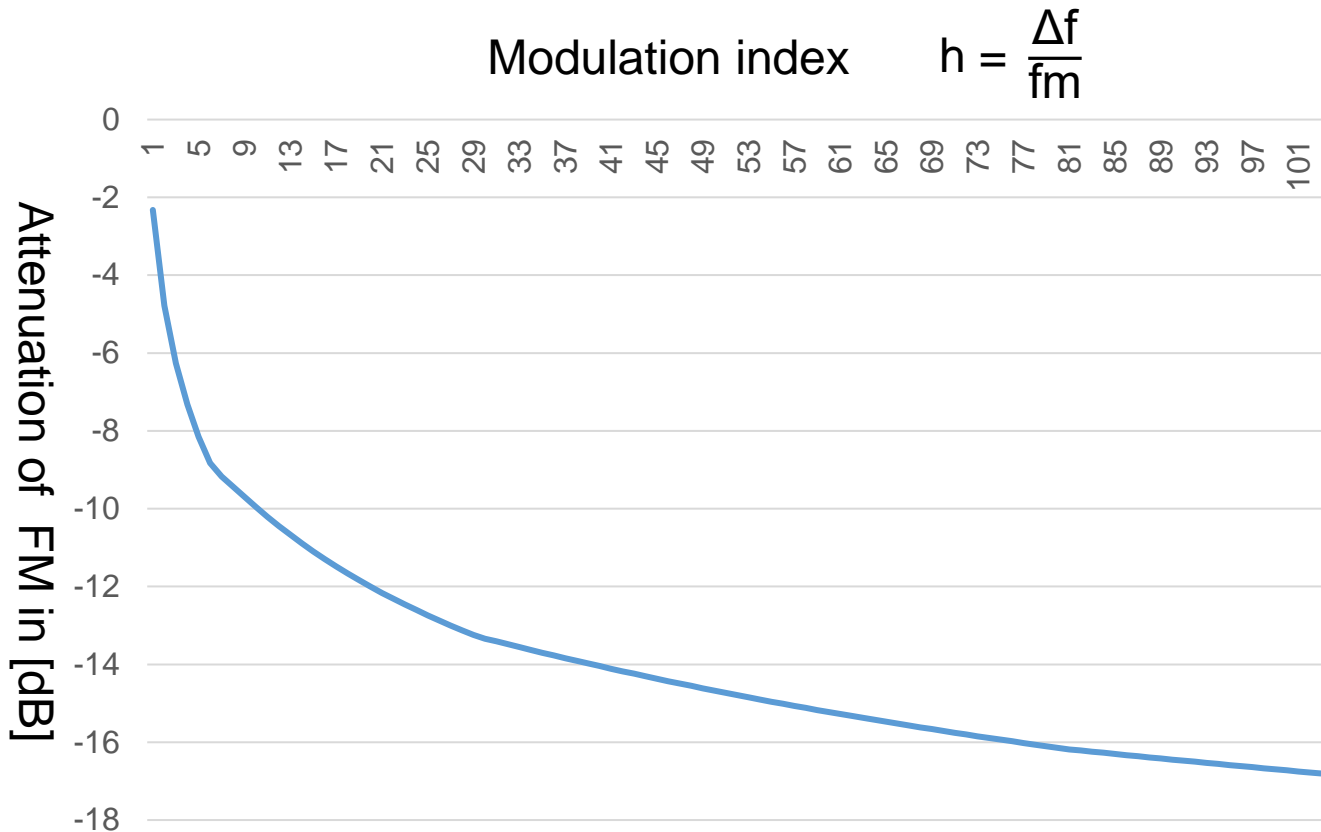

High harmonic numbers easily reach a large modulation index.

However, for fundamental and low harmonic numbers, a low modulation frequency is needed.

This violates the time domain view that is needed to be much faster than 111 μ s or 8.33 μ s out of the RBW window.

Low Modulation Index / High Modulation Frequency Video

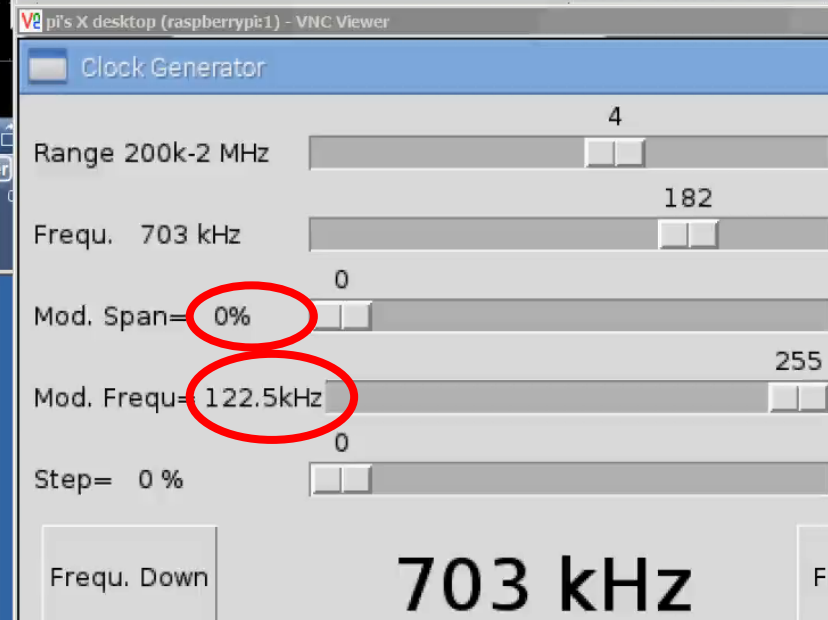
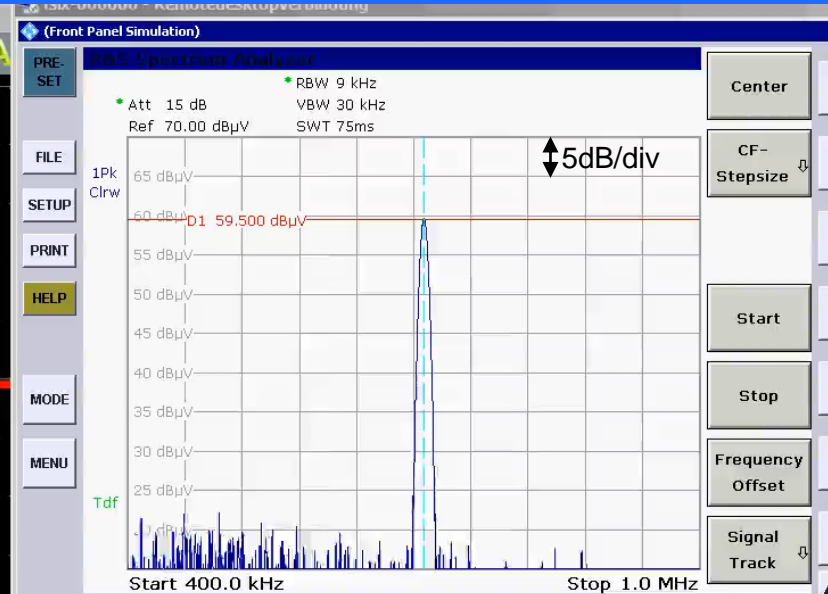
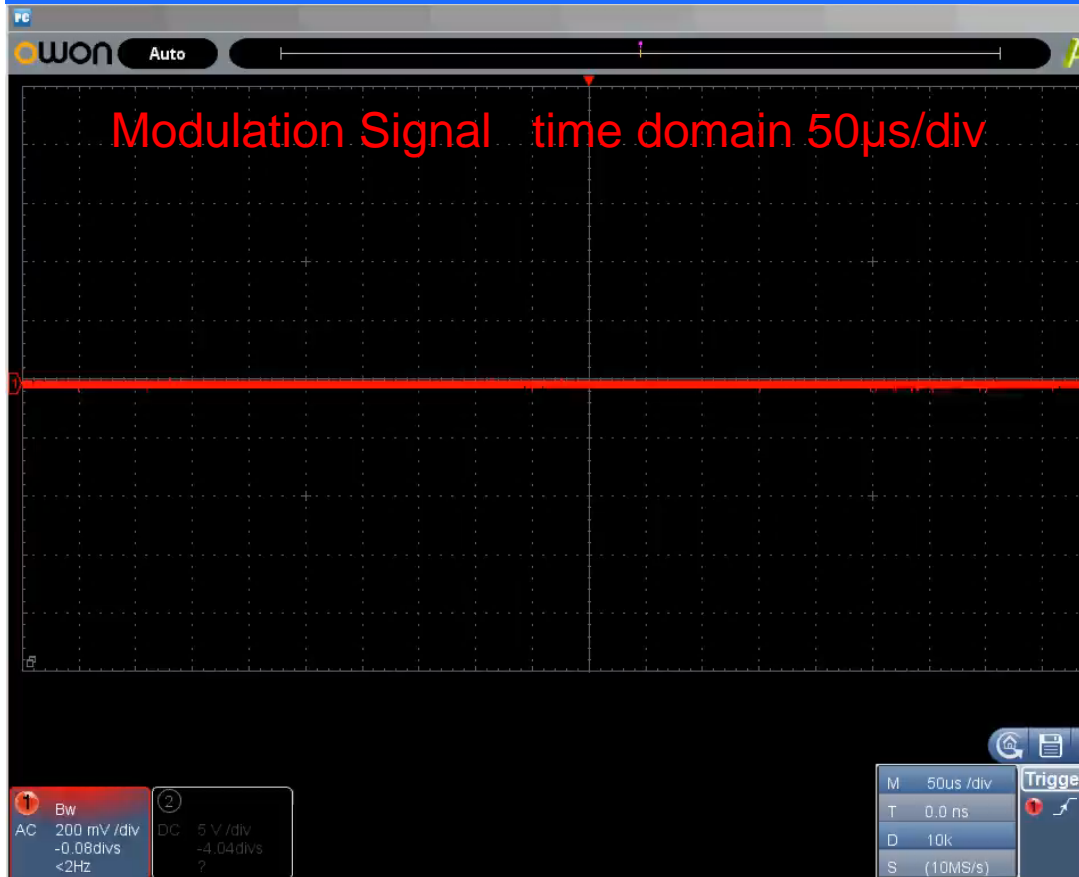

Too high modulation frequency = low modulation index makes only a few spurs with little attenuation.

For the 9kHz RBW area <math>< 30\text{MHz}</math>, a modulation frequency of about 9kHz gives best results.

150kHz to 30MHz View Over Modulation Frequency Video

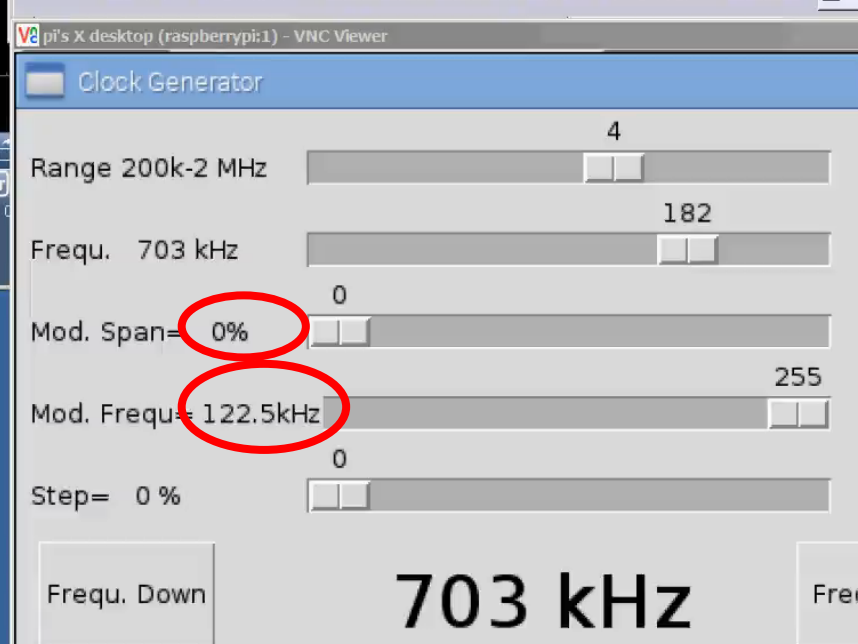
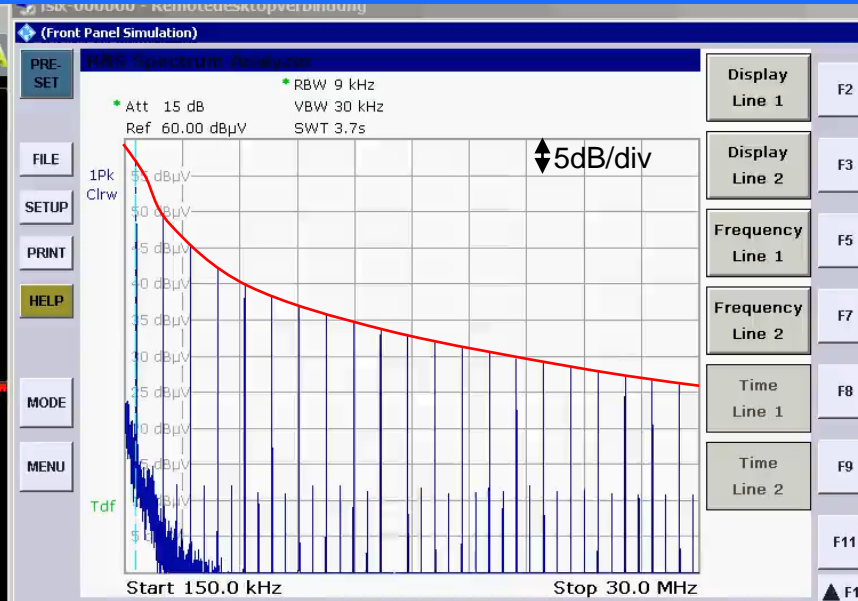
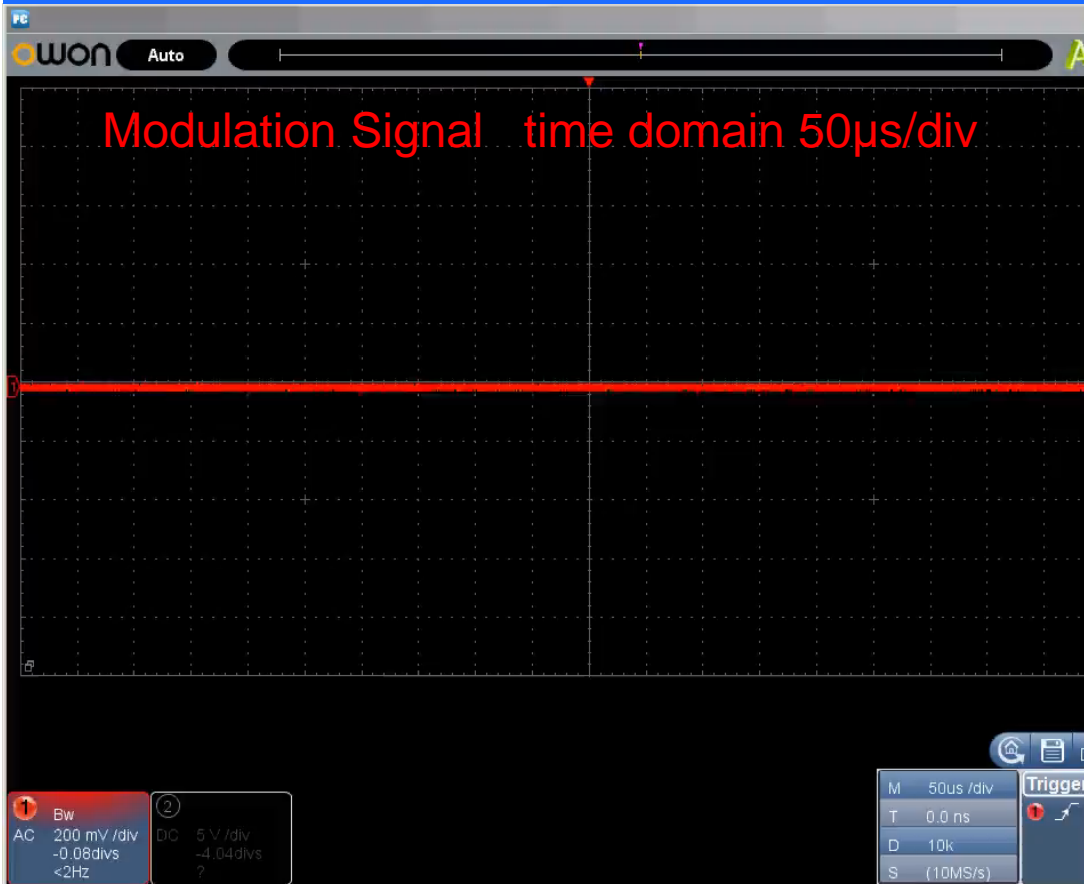

Too high a modulation frequency makes only a few spurs with little attenuation. For the 9kHz RBW area <30MHz, a modulation frequency of about 9kHz gives best results.

Too low modulation frequencies give little attenuation for the fundamental and low harmonics

150kHz to 30MHz View Over Modulation Span Video

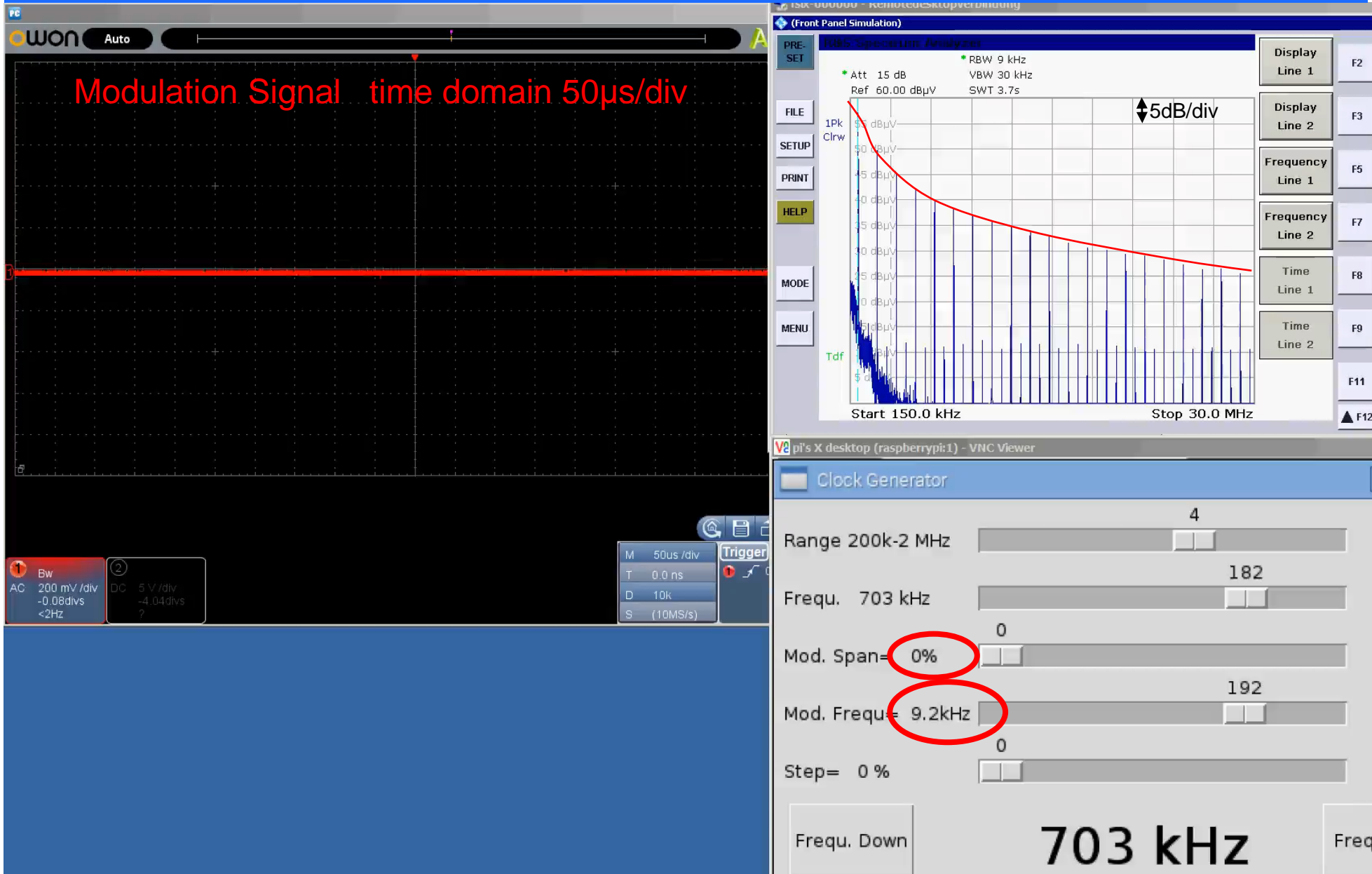

A high modulation span will give good attenuation results, but is demanding on the regulation loop.

Modulation index goes up with modulation span Δf

$$h = \frac{\Delta f}{f_m}$$

120kHz RBW Range >30MHz Video

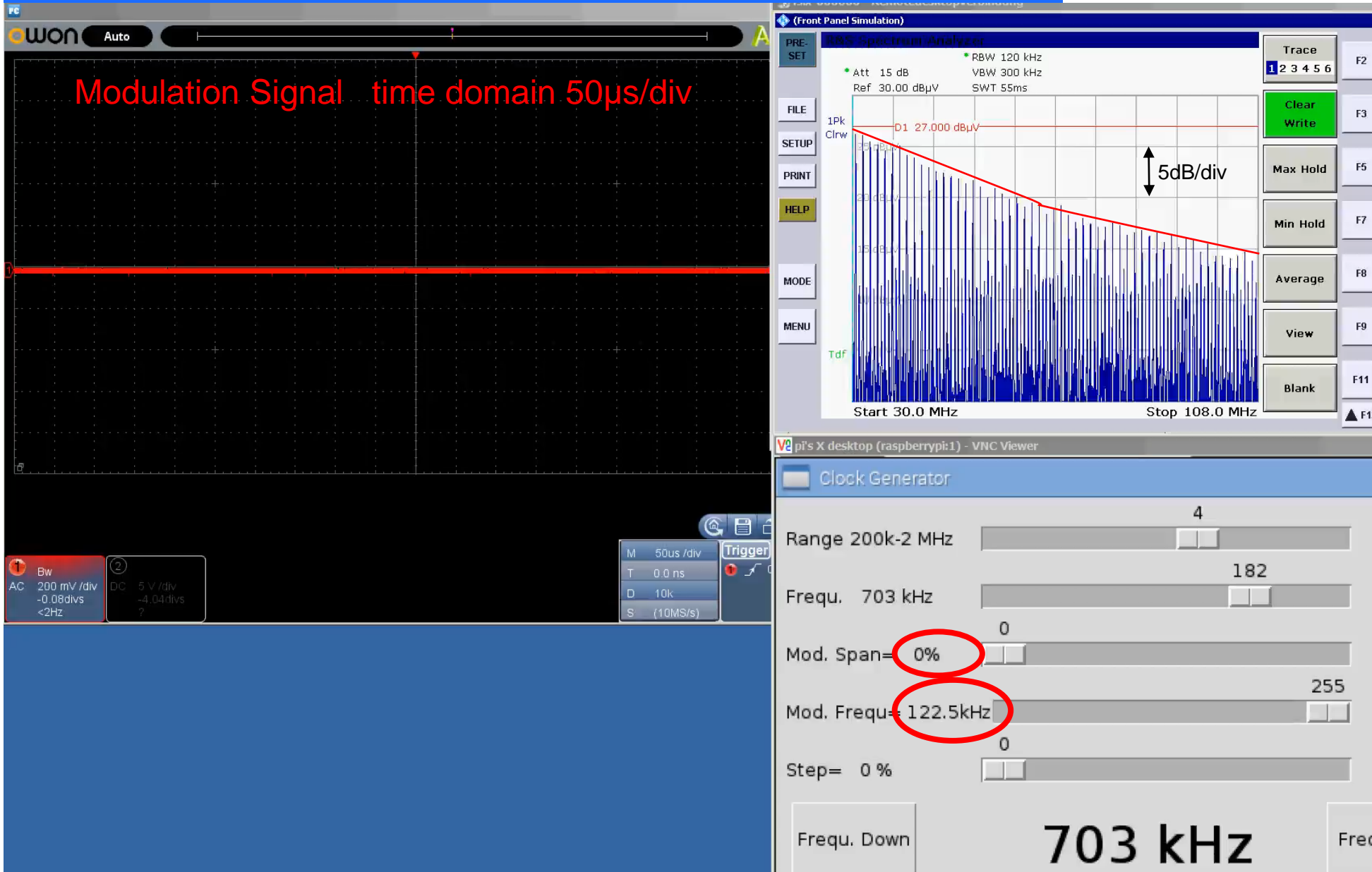

For the 120kHz RBW frequency range, >30MHz high modulation frequency would be best because their spurs still “move” fast enough against the >14.4GHz/s that the 120kHz RBW filter impulse response requires.

The absolute possible attenuation is a lot lower due to the 120kHz RBW filter used above 30MHz

Modulation Frequency

RBW = receiver bandwidth

Too low FM frequency for RBW filter impulse response
Spur stays too long inside RBW

Too low modulation index
Too few spurs with too much individual energy

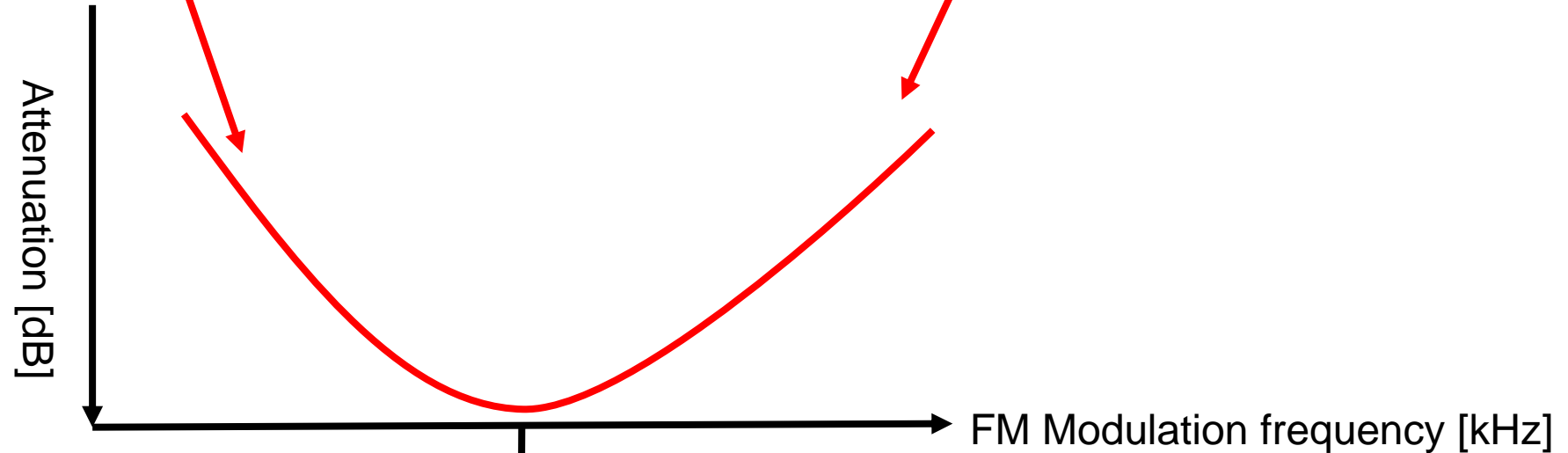

9kHz for <30MHz range or
120kHz for >30Mhz range

Modulation Waveforms

For a given RBW, the modulation frequency should not be too high, or too low.

High modulation frequencies = low modulation index (bad).

Low modulation frequencies = low RBW filter impulse response attenuation (bad).

For typical modulation spans, modulation frequencies around the RBW seem to work best. That is typically 9kHz for the <30MHz range, and 120kHz for the >30MHz region.

Usually, you optimize for the 9kHz RBW range since here get the most attenuation (reward).

Now, what is the best modulation waveform shape?

We know it should be a constant velocity in Hz/s. A high number would be good, but if it is periodic, modulation frequency must return to its start.

Modulation Waveforms – Triangular

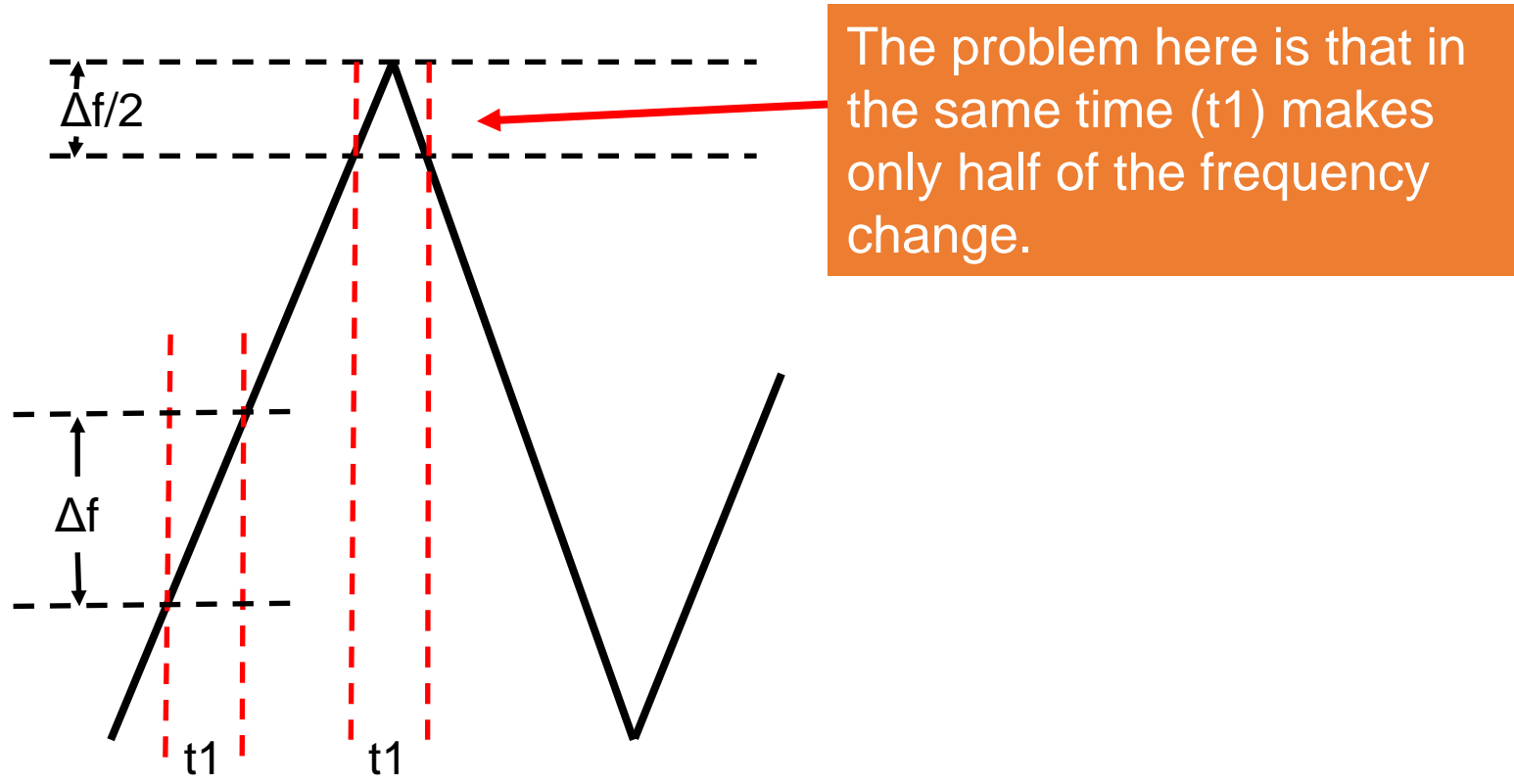

The problem here is that in the same time (t_1) makes only half of the frequency change.

Modulation Waveforms – Sawtooth

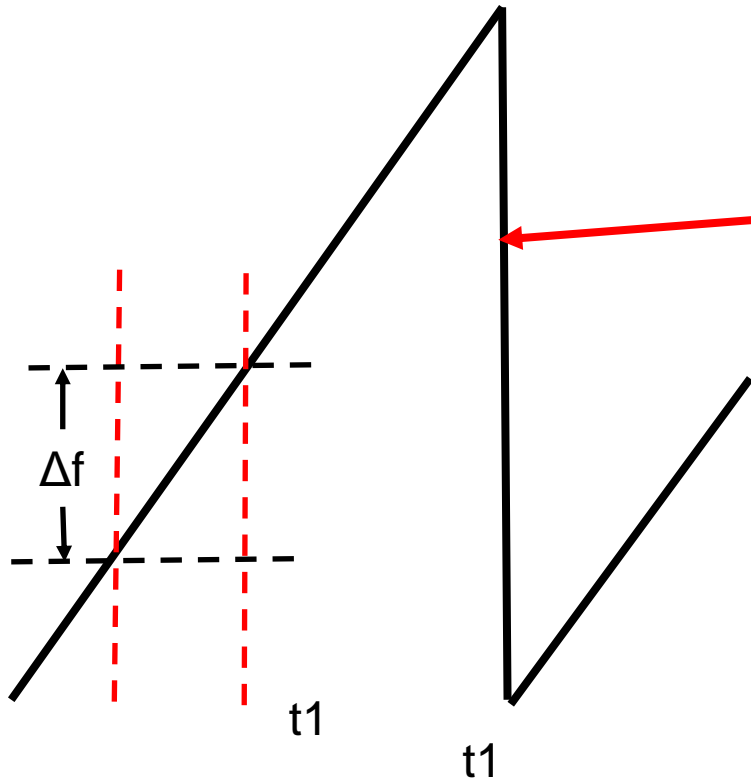

The df/dt here is high or infinity, which is good. However, the abrupt frequency change often creates additional output ripple in fixed frequency control loop designs.

Modulation Waveforms – “Hershey kiss” and Stepped Triangular

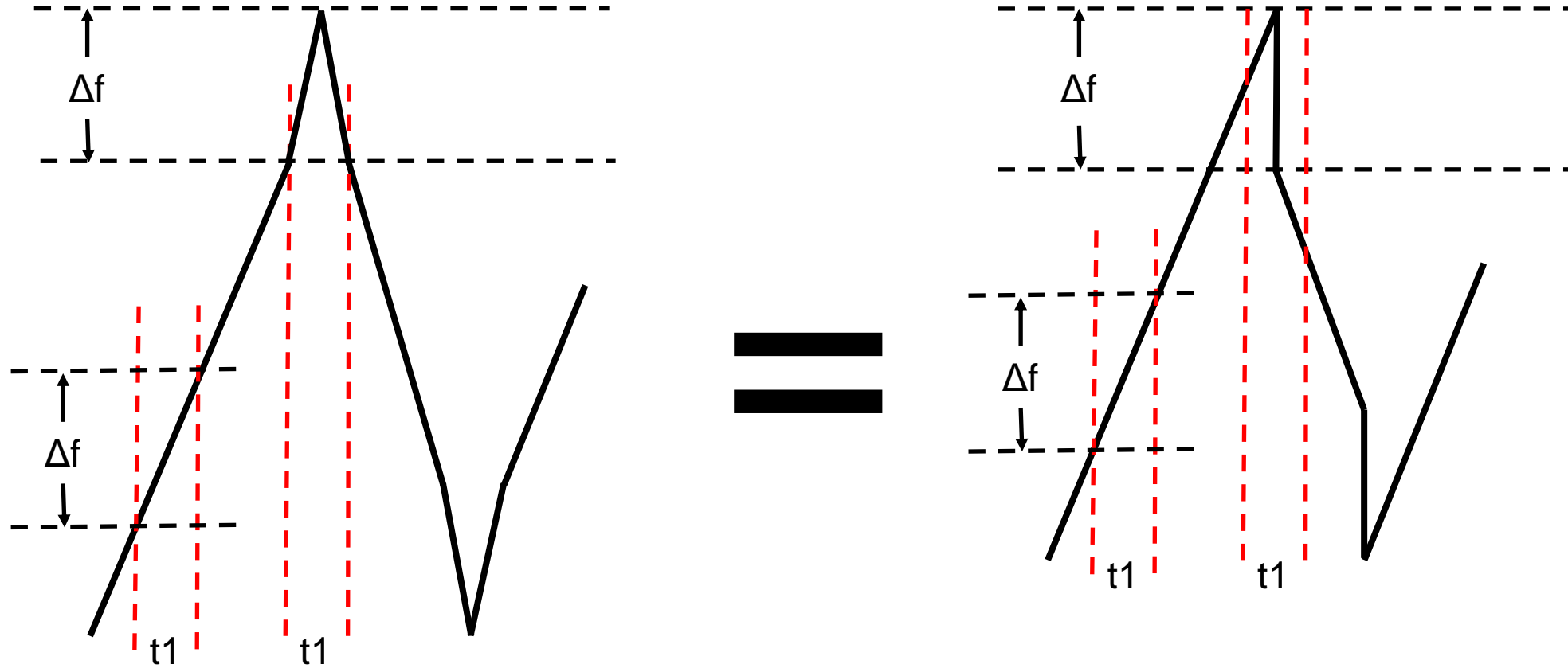

Constant df/dt

Spread Spectrum Implementation for Parts without Internal FSS

If they have a resistor program FREQ pin

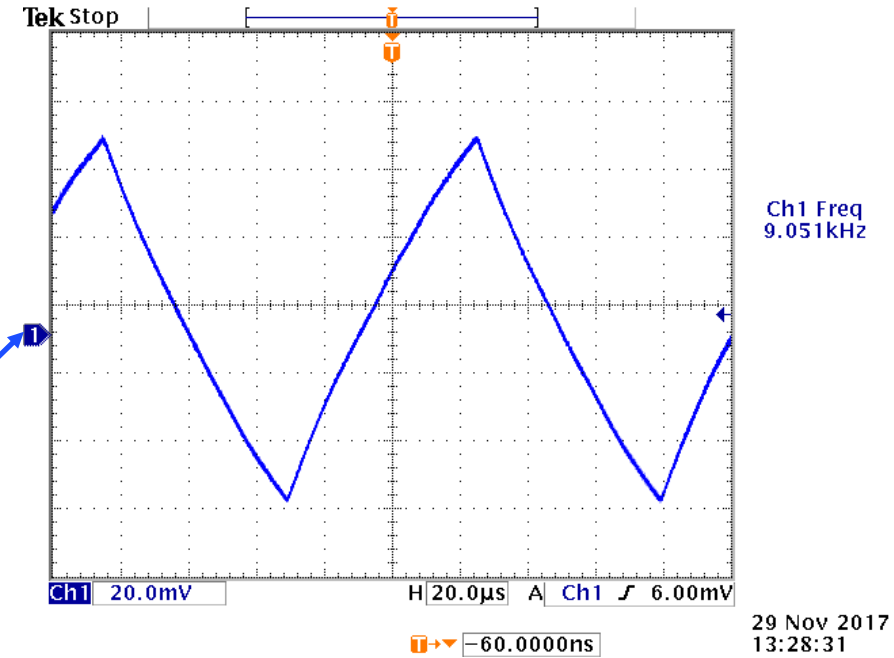
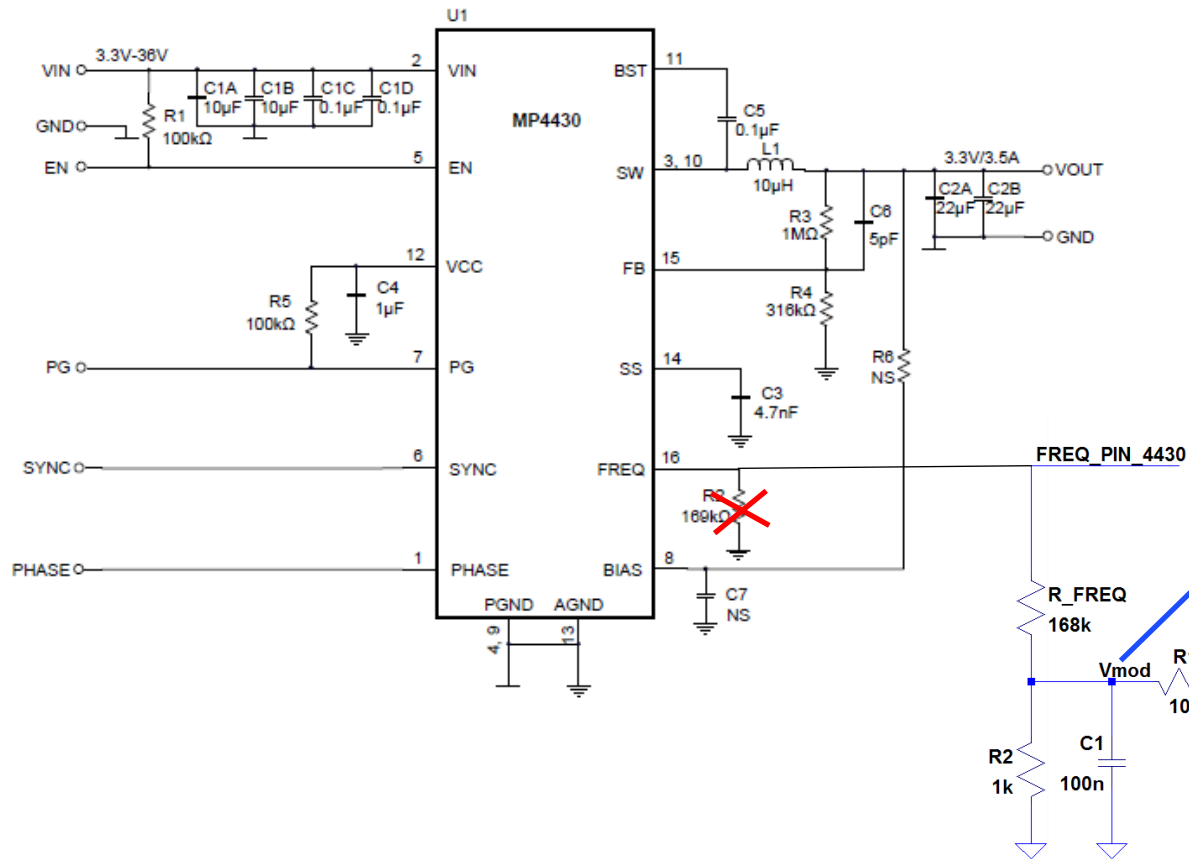

29 Nov 2017
13:28:31

Monopole 150kHz-30MHz Radiated Results for MPQ4430

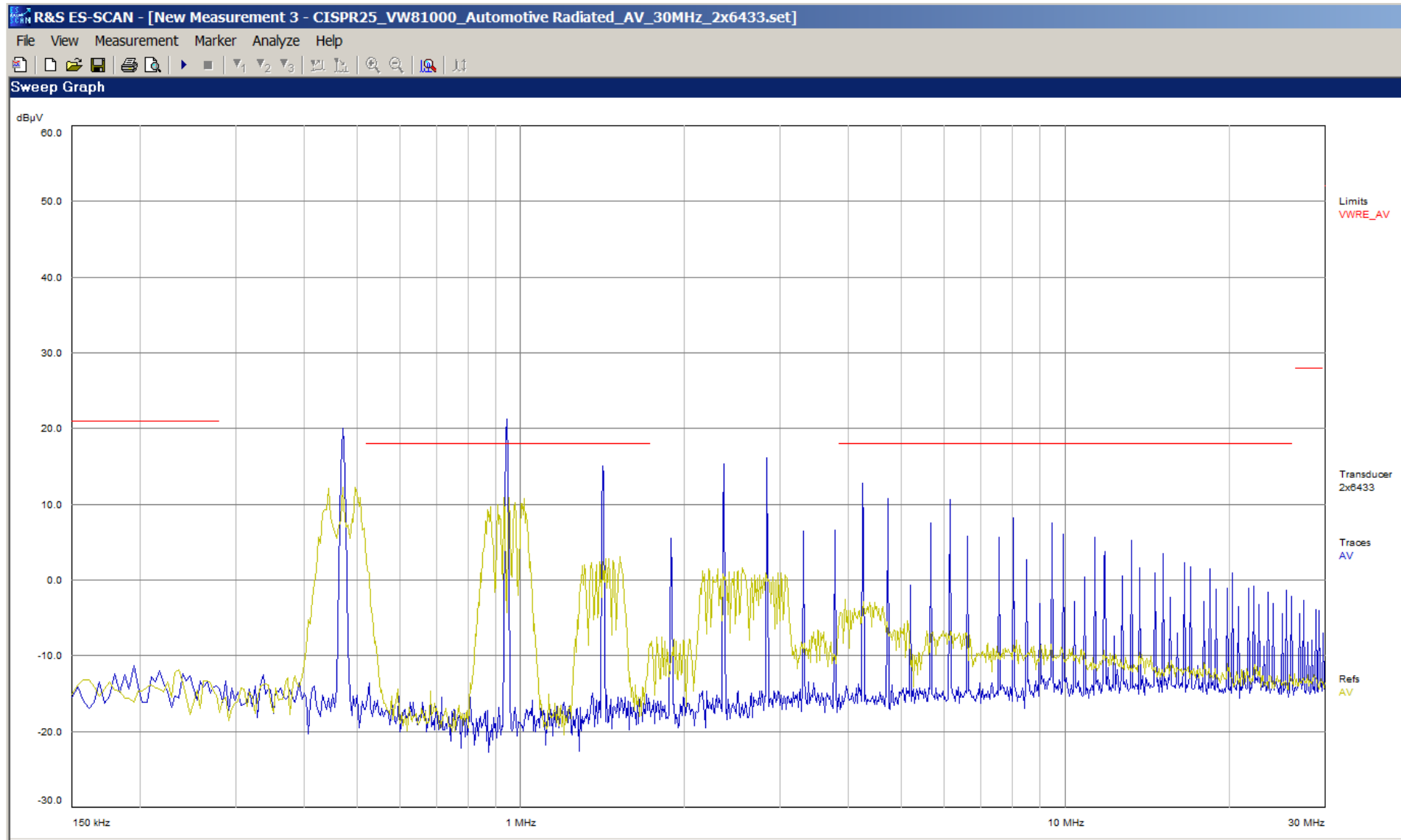

Digital Implementation in the MPQ8875 Video

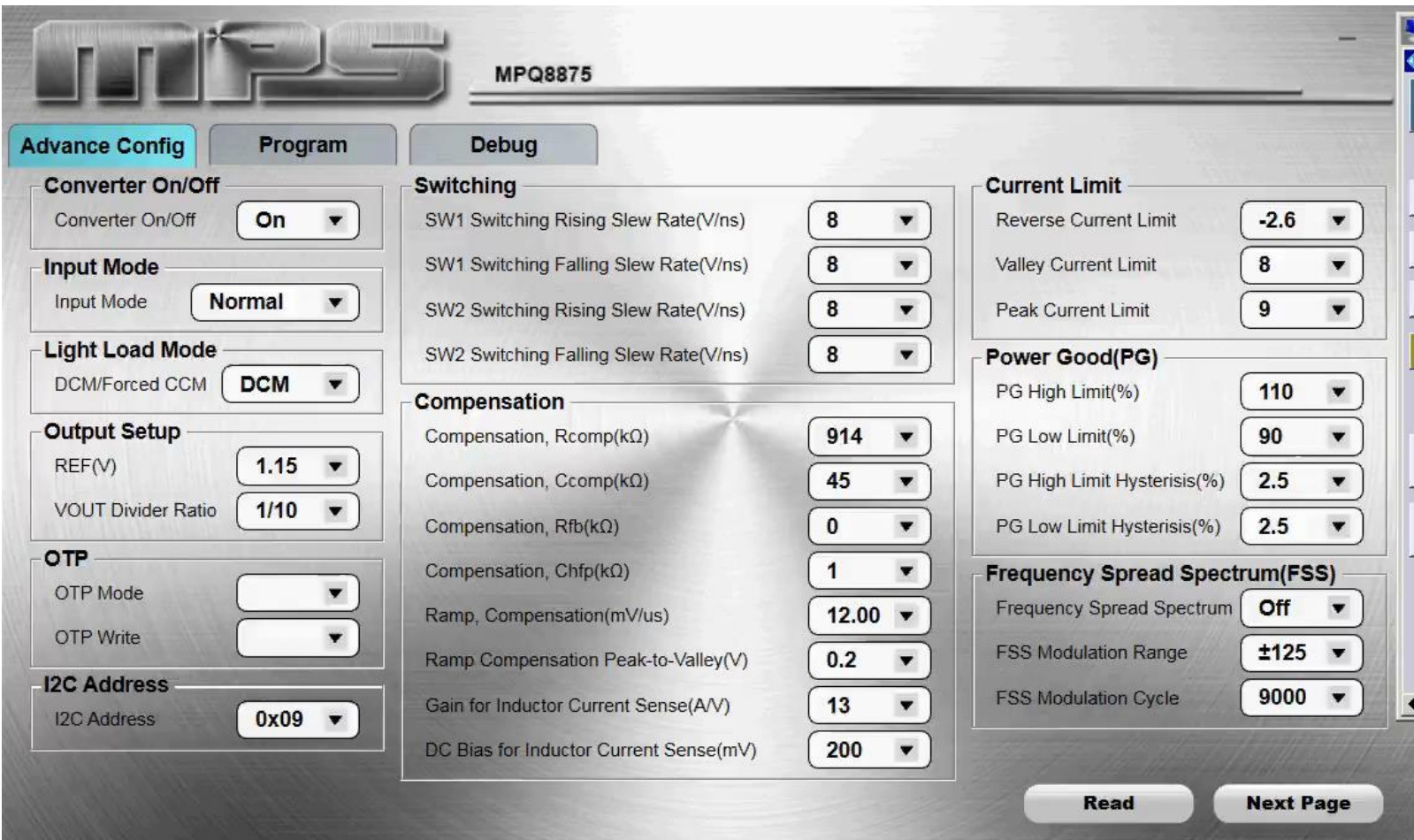

The image shows the configuration interface for the MPQ8875 converter. It is divided into several sections: Advance Config, Program, Debug, Current Limit, Power Good (PG), and Frequency Spread Spectrum (FSS). Each section contains various parameters that can be configured via dropdown menus or input fields.

Advance Config

- Converter On/Off: On
- Input Mode: Normal
- Light Load Mode: DCM
- Output Setup: REF(V) 1.15, VOUT Divider Ratio 1/10
- OTP: OTP Mode, OTP Write
- I2C Address: I2C Address 0x09

Program

Debug

Switching

- SW1 Switching Rising Slew Rate(V/ns): 8
- SW1 Switching Falling Slew Rate(V/ns): 8
- SW2 Switching Rising Slew Rate(V/ns): 8
- SW2 Switching Falling Slew Rate(V/ns): 8

Compensation

- Compensation, Rcomp(kΩ): 914
- Compensation, Ccomp(kΩ): 45
- Compensation, Rfb(kΩ): 0
- Compensation, Chfp(kΩ): 1
- Ramp, Compensation(mV/us): 12.00
- Ramp Compensation Peak-to-Valley(V): 0.2
- Gain for Inductor Current Sense(A/V): 13
- DC Bias for Inductor Current Sense(mV): 200

Current Limit

- Reverse Current Limit: -2.6
- Valley Current Limit: 8
- Peak Current Limit: 9

Power Good (PG)

- PG High Limit(%): 110
- PG Low Limit(%): 90
- PG High Limit Hysteresis(%): 2.5
- PG Low Limit Hysteresis(%): 2.5

Frequency Spread Spectrum (FSS)

- Frequency Spread Spectrum: Off
- FSS Modulation Range: ±125
- FSS Modulation Cycle: 9000

Buttons: Read, Next Page

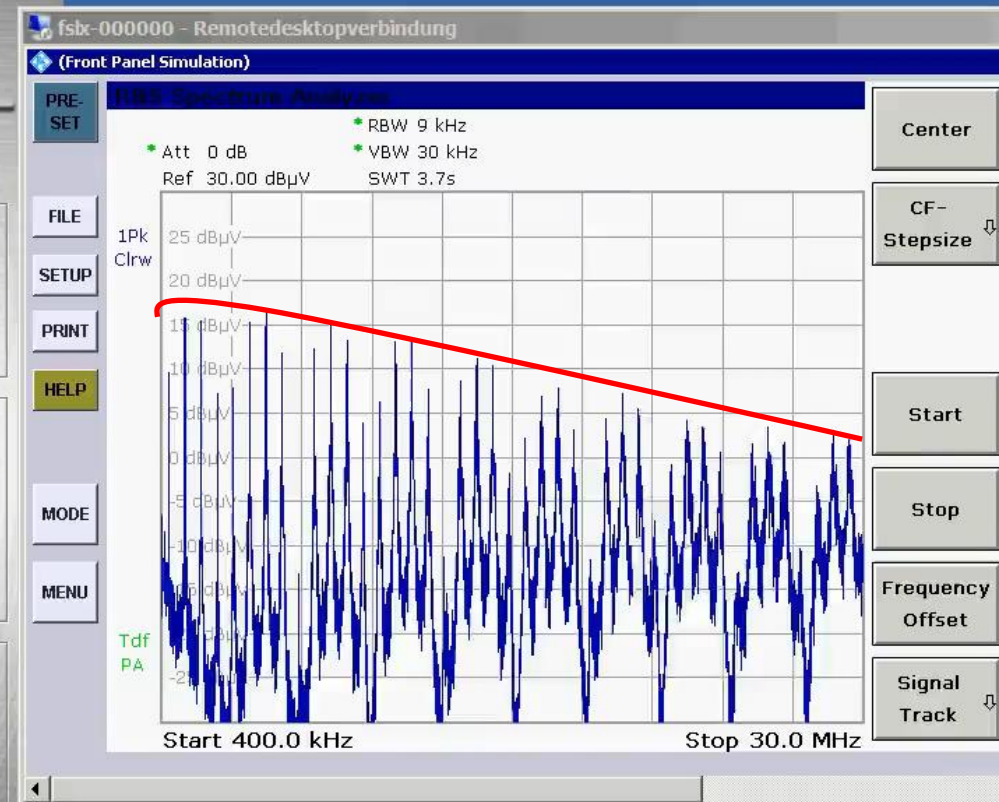

Spread Spectrum Benefits

Spread spectrum works independently from other EMI mitigation methods like filtering, layout, and shielding. Therefore, fixed frequency design results get additional attenuation from spread spectrum, in conducted and radiated areas.

A good engineering practice is to develop and test the switch mode PSU first with fixed frequency. Using spread spectrum from the design evaluation start may hide excessive jitter or stability issues.

General spread spectrum adds a minimal additional output ripple to fixed frequency designs. On non-fixed frequency loop topologies like COT, hysteretic, and fixed ripple, one might not see anything additional at the output.

Transient response is not affected unless excessive frequency spans are used.

What is the optimum switching Frequency

EMI goes general up with voltage on the switch node by 6dB for every 2x switch voltage

So for 5V or 3.3V V_{in} switchers you get away with >2MHz switching frequency. Keep the inductors small and low profile.

For higher V_{sw} switchers like 12V and more keep the switching frequency as low as practical typical sub AM band.

EMI goes up 6dB on a fixed frequency switcher for every frequency doubling and even perfect spread spectrum buys you only 3dB back.

Frequency Synchronisation

Even fixed frequency switchers have some phase noise (FM) which will multiply by the harmonic number. So expect some natural FM attenuation on high harmonic numbers (i.e. >80MHz).

On non fixed frequency schemes like COT those natural phase noise / FM is even more pronounced. This gives you some spread spectrum effect for free.

If you sync your switchers to a common high quality oscillator you lose all those benefits and wind up with a perfect comb spectrum up to very high harmonics.

Sync to a high quality oscillator only when for your system it is absolutely necessary

Conclusion

Spread spectrum is an excellent tool to reduce EMI with little additional cost

The optimum modulation frequency for each EMI RBW is around the RBW frequency

Optimize with spread spectrum for 9kHz RBW in the <30MHz frequency band

Spread spectrum optimized for <30MHz, saves the most by reduced filter and shielding requirements

Test PSU first with a fixed frequency setting

Parts with an external FREQ setting resistor can be easily made spread spectrum

Excessive frequency span only helps for the first few harmonics, not in the overlap region

The effect of 120kHz RBW or more (>30Mhz range) offers limited improved optimizing for 9kHz RBW

FAQ: Question 1

How many dBs maximum reduction can I get from the MPS spread spectrum feature?

See table on slide 14

Maximum Achievable Spread Spectrum Attenuation			
	0.15MHz–30MHz	30MHz–1GHz	>1GHz
RBW [kHz]	9	120	1000
f_{sw} [kHz]	[dB]	[dB]	[dB]
100	-10.5	0.0	0.0
200	-13.5	-2.2	0.0
400	-16.5	-5.2	0.0
1000	-20.5	-9.2	0.0
2000	-23.5	-12.2	-3.0
3000	-25.2	-14.0	-4.8
5000	-27.4	-16.2	-7.0
10000	-30.5	-19.2	-10.0
100000	-40.5	-29.2	-20.0

FAQ: Question 2

Q: Does spread spectrum affect the transient response of a DC/DC buck regulator?

A: It has almost no effect since the mean switching frequency and control loop stays the same.

FAQ: Question 3

Q: Which algorithm is used to generate spread spectrum inside MPS's DC/DC converters?

A: Analog triangle or stepped triangle generators are used as well as digital implementations. As long as the digital implementation changes the frequency value on each switch node cycle, there is no difference in the resulting spectrum and attenuation to an analog solution.

FAQ: Question 4

Q: Which frequency modulation envelope is more effective: sawtooth, triangle, or sinusoid?

A: Sawtooth and stepped triangle are the most effective. However, sawtooth makes a jump over the complete range in one step, which can introduce loop perturbation for the switcher. Because of this, a more continuous method like triangle or stepped triangle are often used.

With sinusoid or even rectangular modulation the top and bottom signal stays too long around in a small frequency range (inside the RBW), which results in poor attenuation.

FAQ: Question 5

Q: What is the cost difference, if any, to be expected in a SS part vs. non-SS part? Will there be an overall reduction in system cost (capacitors, inductor, filters)?

A: The additional spread spectrum audio frequency modulator adds very little area on the device, so the additional cost is low.

The biggest solution cost improvement is on the filter requirements for the lower frequency area from switching frequency to the first harmonics.

Often, spread spectrums save the complete solution, so ultimately only you can answer what your project is worth.

FAQ: Question 6

Q: Does spread spectrum really help the EMI? Or just cheat the test equipment?

A: The total emitted energy into the universe stays the same. You change the spectral distribution.

FAQ: Question 7

Q: Which kind of EMI does it help? CE? RE? <30MHz? >30MHz?

A: All. Spread spectrum is a spectral method, and always gives additional dB attenuation which add to conventional methods like filtering, layout, and shielding.

Therefore, it helps for conducted and radiated, and gives the same dB attenuation at any frequency, whether radiated and conducted.

With the different RBW (receiver bandwidth) of 9kHz <30MHz, 120kHz >30MHz, and 1MHz >1GHz, in some OEM defined ranges spread spectrum attenuates the most for low RBW like 9kHz.

See slide 16 for carrier frequency change minimums.

150kHz to 30MHz	with RBW = 9kHz	> 81MHz/s
30MHz to 1GHz	with RBW = 120KHz	> 14.4GHz/s
>1GHz	with RBW = 1MHz	> 1THz/s

FAQ: Question 8

Q: Are there any secret military or patented spread spectrum methods to get more attenuation?

A: Spread spectrum works to the basic principle of quantum physics according to Heisenberg's uncertainty principle (frequency form) $\Delta f * \Delta t \leq 1$

The best method is to spread signal energy evenly over the spectrum. For a comb-style periodic spectrum, only the area in between two comb teeth can be filled.

This reduces the possible attenuation to the formula from slide 14:

$$\text{Attenuation} = 10 * \log_{10} \left(\frac{RBW}{f_{sw}} \right)$$

FAQ: Question 9

Q: Why random or pseudo-random modulation can be a bad choice?

A: PSU spread spectrum has to use a constant power modulation scheme, which is FM. FM gives a quadratic spectral energy between \pm Carson frequency. Therefore, low modulation frequencies make more spectral energy than high ones for the same frequency span.

That is the reason that audio FM modulation uses pre-emphasis (50 μ s in Europe 75 μ s in US). Otherwise, the signal to noise ratio for high frequencies would be much lower than for low frequencies. Low carrier movement staying inside the RBW does not give any attenuation at all.

White noise/random or pseudo-random yields a flat frequency response. One would have to differentiate the noise signal (high frequencies amplified), pre-emphasize it, and cut out the low amplitude area, which would result in the carrier staying inside the RBW. The high frequency range requires limiting the energy giving a low modulation index. In total, one would have to bandpass, pre-emphasize, and omit low-amplitude changes (inside RBW). In the end, the signal would not be much different from a stepped triangle.

Currently, white noise/pseudo-random generators give lower attenuation than otherwise possible for the above reasons.

MPS operates 3 EMC Labs worldwide open to customer use

SAC3 – Chamber
CISPR25 – Chamber
Shielded – Chamber
Pulses and Application Engineering

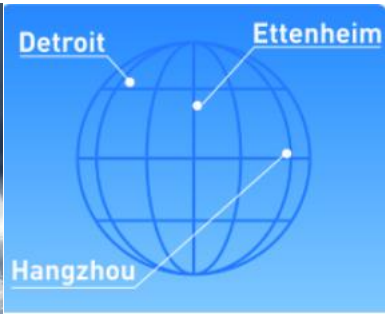

- Locations**
- 📍 Detroit, USA
 - 📍 Ettenheim, DE
 - 📍 Hangzhou, CN

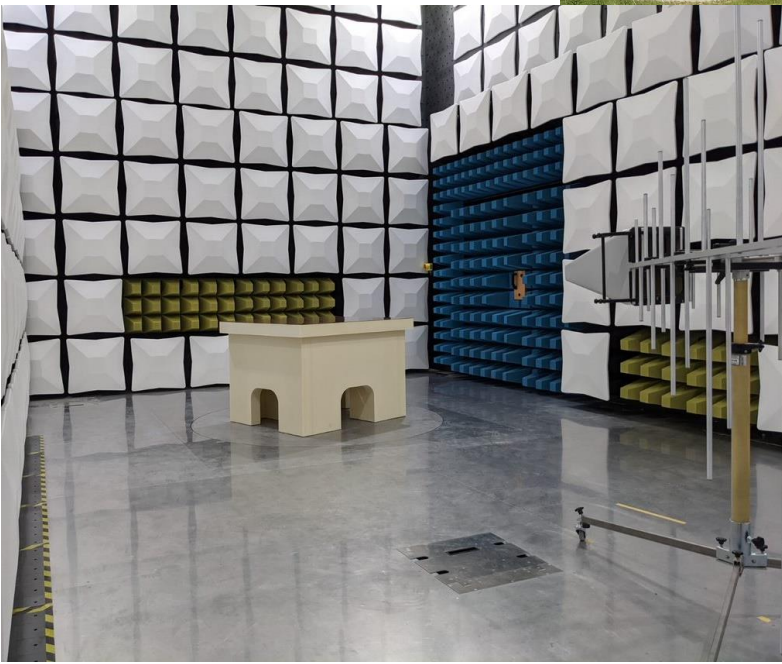

Attachment Optimum Modulation Frequency and Spread

Maximize $N * F_{mod} * \Delta F$

RBW impulse response

Minimize $N * \Delta F$

Overlap starts

Maximize $\sqrt[3]{\frac{N * \Delta F}{F_{mod}}}$

Modulation index attenuation from FM modulation math

Conflicting so there is an optimum middle ground

N = Harmonic Number

F_{mod} = Modulation Frequency

ΔF = Frequency Span

Attachment FM Modulation

In the frequency domain, FM modulated signals have a discrete spectrum spaced by the modulation signal frequency, with magnitudes according to the Bessel function of the first kind. Measure the modulation frequency using low RBW (e.g. 100Hz) on the analyzer.

Excel supports the Bessel function of the first kind, so there is an opportunity for deeper research if interested

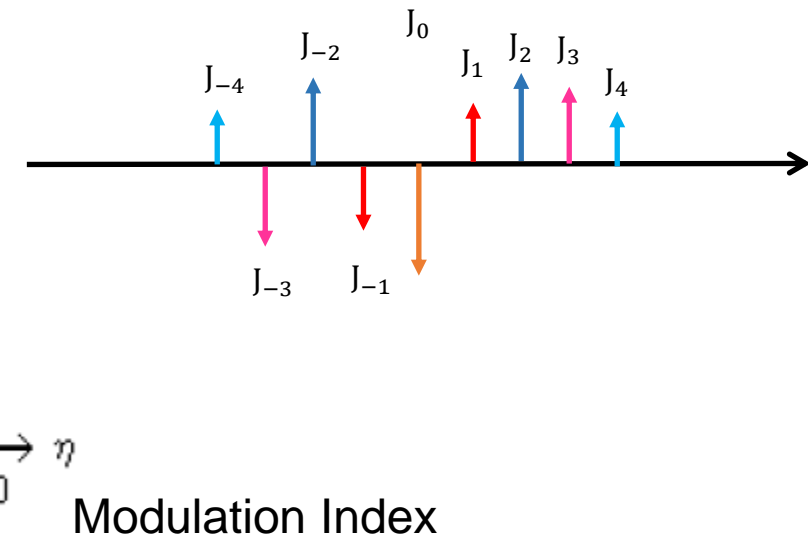
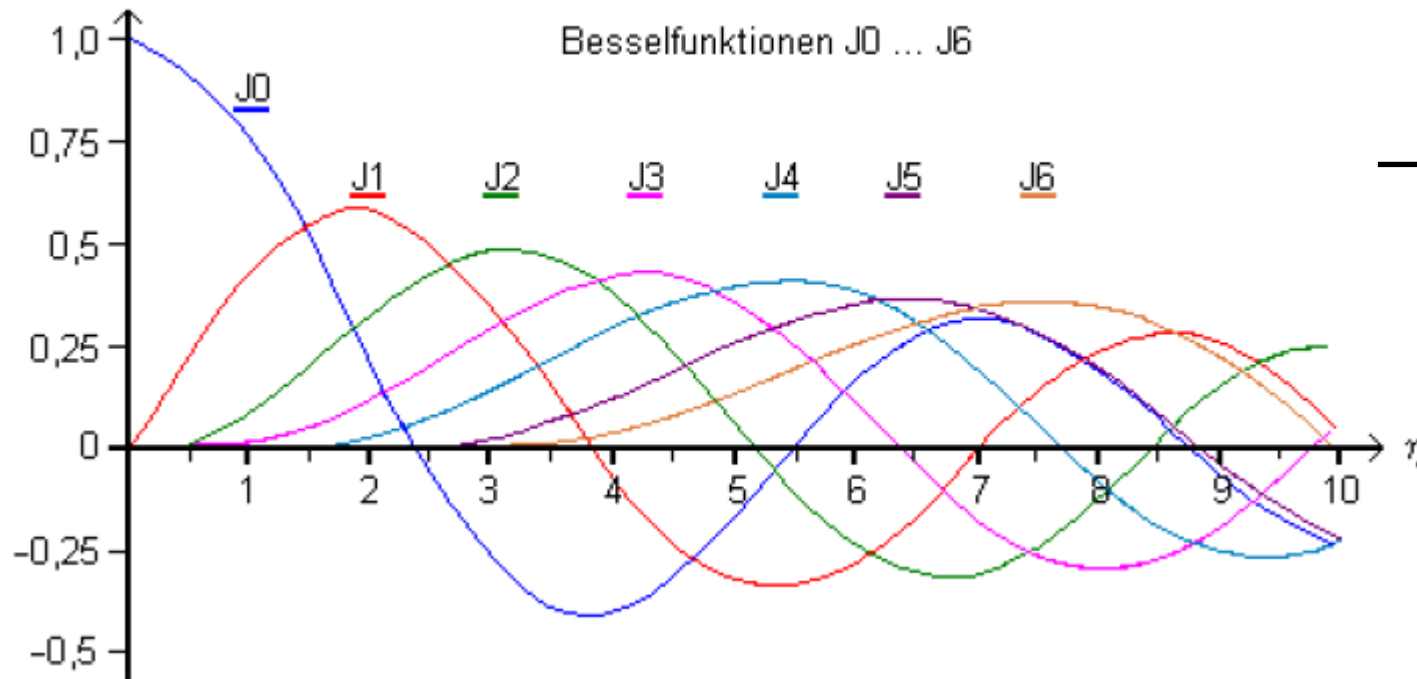

Attachment Overlap

The spread frequency span goes up with the harmonic number N , and starts to overlap at a certain frequency.

Above the overlap frequency, EMI will not improve by increasing the modulation frequency span/spread.

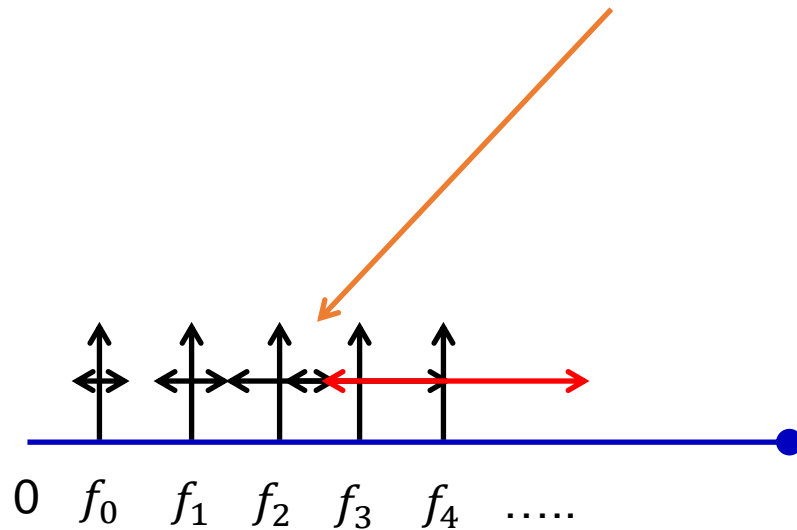

Attachment Switching Frequency Effect on EMI

Doubling the switching frequency doubles the number of switch transitions, so it is best to double the EMI energy. That is 3dB more (power is $10 * \log(2)$).

But with double the frequency, only half the bins are available to locate this energy.

The spurs have 6dB more amplitude per doubling the frequency for fixed frequency, and at least 3dB more for a perfect working spread spectrum.

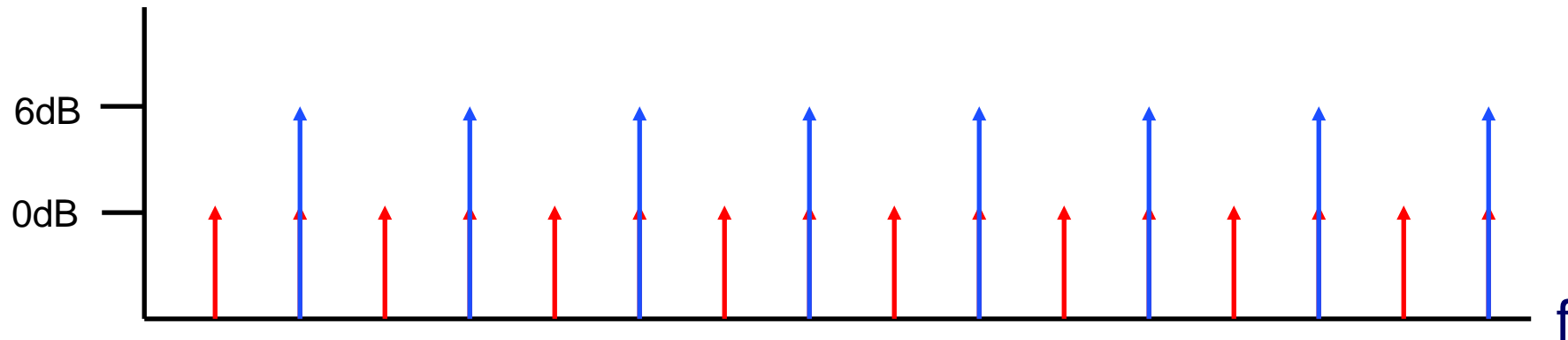

Attachment Switching Frequency Effect on EMI

If all stays the same except the switching frequency:

With fixed frequency for every doubling, only half the bins are available for the energy.
Result is 6dB/octave = 20db/decade

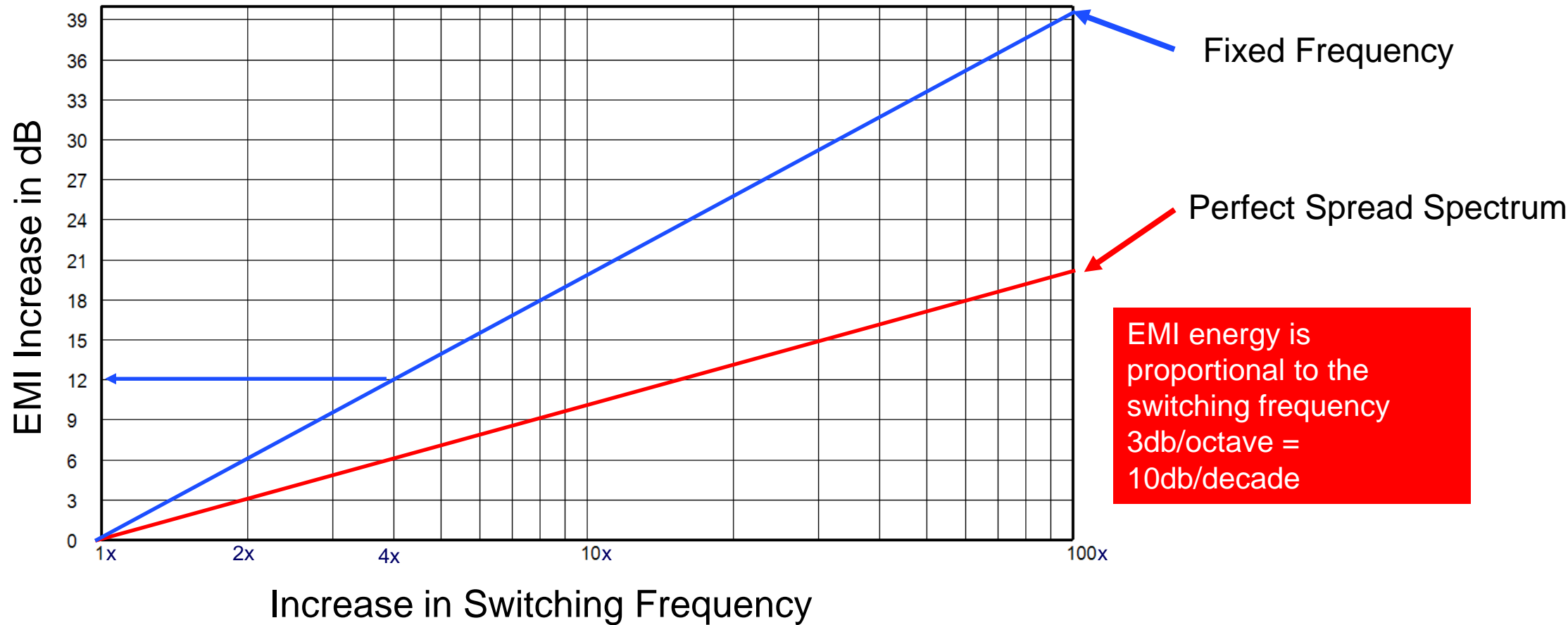

EMI energy is proportional to the switching frequency
3db/octave = 10db/decade

Pseudo-Random Noise for Spread Spectrum Modulation

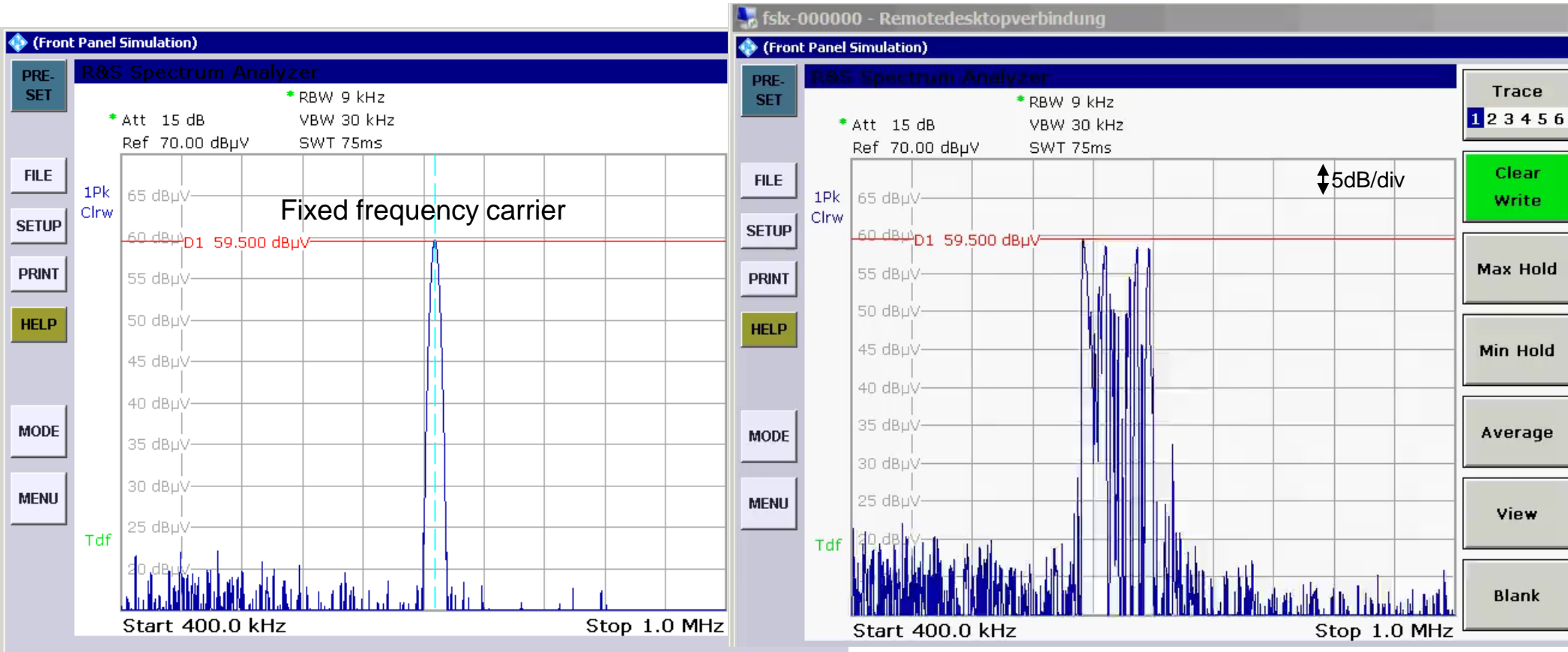

[19]

Industry-available, pseudo-random spread spectrum generator.

No attenuation in PK nor in AV mode at 9kHz RBW.

Pseudo-Random 150kHz to 30MHz

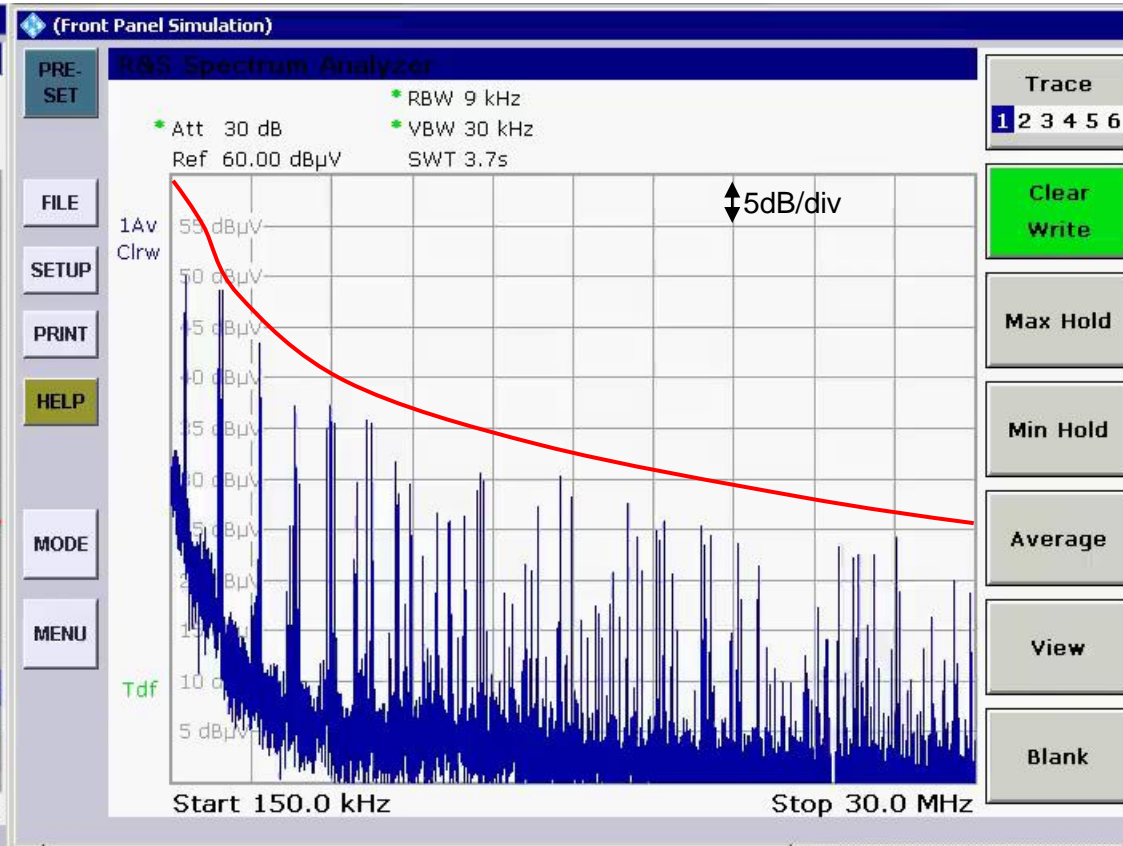
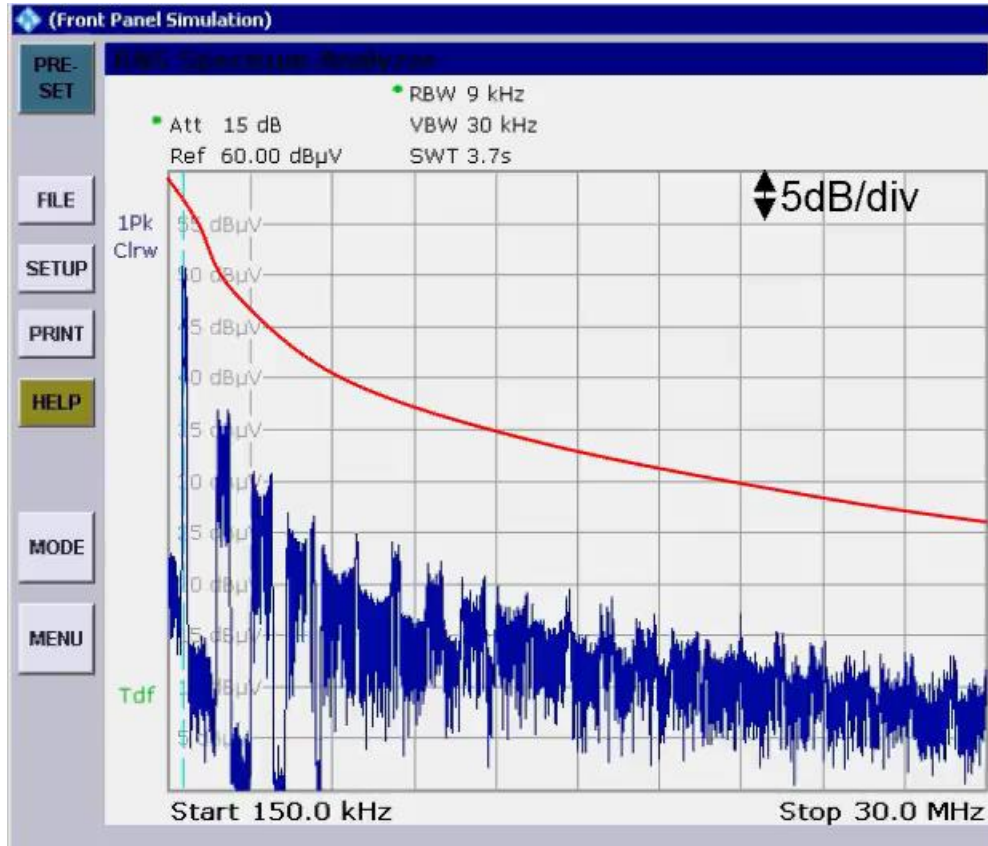

[20]

9kHz Triangle Modulation @ 20% Span

Industry-available, pseudo-random spread spectrum generator. A few dB.