



EVKT-BMU1xx-HP Product Brief

MP279x and MPF4279x Evaluation Kit

High-Power Battery Management Unit Reference Design for 7-Cell to 16-Cell Batteries with MPS's Analog Front-End and Fuel Gauge

The EVKT-BMU1xx-HP is an evaluation kit for the EVBMU1xx-HP-R-01A, a reference design board for high-current designs with a 7-cell to 16-cell series battery management unit.

This board uses the MP279x ICs, a robust family of battery management analog front-ends (AFEs) that provide a complete AFE monitoring and protection solution. The MP279x supports up to 16 cells in series, and provides two separate analog-to-digital converters (ADCs) for synchronous voltage and current measurements. The high-side MOSFET (HS-FET) driver and robust HW protection functions come with configurable thresholds. Protections include over-current protection (OCP), short-circuit protection (SCP), battery and cell over-voltage protection (OVP), battery and cell under-voltage protection (UVP), over-temperature protection (OTP), and under-temperature protection (UTP). The MP279x also integrates internal balancing FETs to equalize mismatched cells while offering the option to control external FETs for a higher balancing current.

The board also features the MPF4279x, a standalone battery fuel gauge IC that performs state-of-charge (SoC), time-to-full, time-to-empty, and unavailable energy estimation using a custom battery model obtained through exhaustive characterization and voltage, current, and temperature readings. This solution is fast, simple, and easy to configure through the graphic user interface (GUI).

The board offers a high-power solution with up to 100A of constant current and up to 150A of peak current. Each board offers a different combination of the MP279x and MPF4279x.

Kit Contents

- EVBMU1xx evaluation board (EVBMU1xx-HP-R-01A)
- Communication interface with accessories (EVKT-USB_RS485/I2C-01)
 - USB to RS-485/I2C adapter
- MP279x and MPF4279x ICs (MP279xDFP-0001-T and MPF4279xDRT-0B-0001) with one-time programmable (OTP) memory

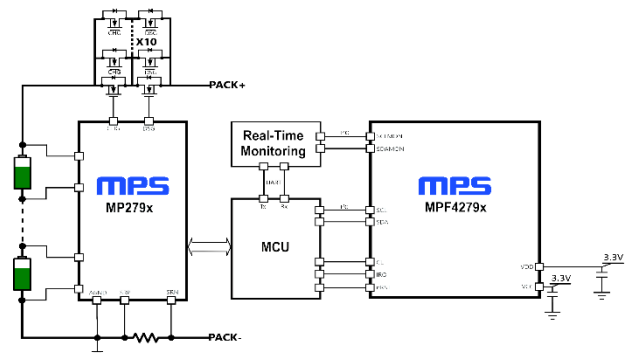

Feature	Specifications
Battery Pack Voltage	18V to 70.4V (16-cell battery)
	18V to 65.8V (14-cell battery)
	18V to 44V (10-cell battery)
Charger Voltage	18V to 72V (16-cell battery)
	18V to 67.8V (14-cell battery)
	18V to 46V (10-cell battery)
Parallel Protection NFETs	1 to 10
EVB Size (LxW)	123x121mm;
	97xx61mm

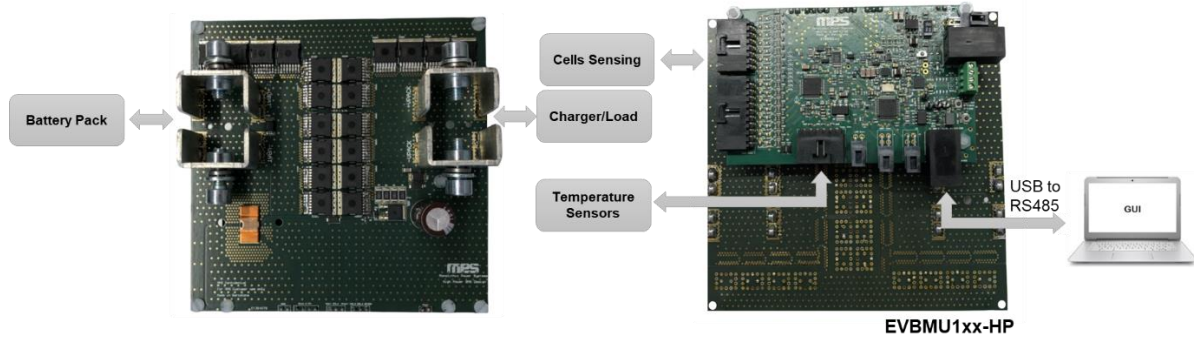

Figure 1: EVBMU1xx-R-01A Evaluation Kit Set-Up

Evaluation Kits (The table below helps select the right evaluation kit.)

Reference Design	MPF4279x Part Number	MPF4279x Short Description	MP279x Part Number	MP279x Short Description
EVBMU16S-R-01A	MPF42790	2-Cell to 16-Cell FG with Level LEDs	MP2797	7-Cell to 16-Cell BMS with I ² C
EVBMU16SNL-R-01A	MPF42792	2-Cell to 16-Cell FG	MP2797	7-Cell to 16-Cell BMS with I ² C
EVBMU14S-R-01A	MPF42790	2-Cell to 14-Cell FG with Level LEDs	MP2791	7-Cell to 14-Cell BMS with I ² C
EVBMU10S-R-01A	MPF42795	2-Cell to 10-Cell FG with Level LEDs	MP2791	7-Cell to 14-Cell BMS with I ² C
EVBMU10SNL-R-01A	MPF42797	2-Cell to 10-Cell FG	MP2791	7-Cell to 14-Cell BMS with I ² C
EVBMU16S-G1-R-01A	MPF42791	Next Generation 2-Cell to 16-Cell FG with Level LEDs	MP2797	7-Cell to 16-Cell BMS with I ² C
EVBMU14S-G1-R-01A	MPF42791	Next Generation 2-Cell to 14-Cell FG with Level LEDs	MP2791	7-Cell to 14-Cell BMS with I ² C

Quick Start (Refer to the user guide for more details.)

1. Install the GUI software.
2. Use the EVKT-USB_RS232/I2C-01 to connect the evaluation board to the RS-485 interface.
3. Preset the power supply within the specified range.
4. Connect the communication interface to the PC, then turn the power supply on.
5. Open the GUI software and select the evaluation board.

* Kit offers rapid application assessment and requires minimal external components.

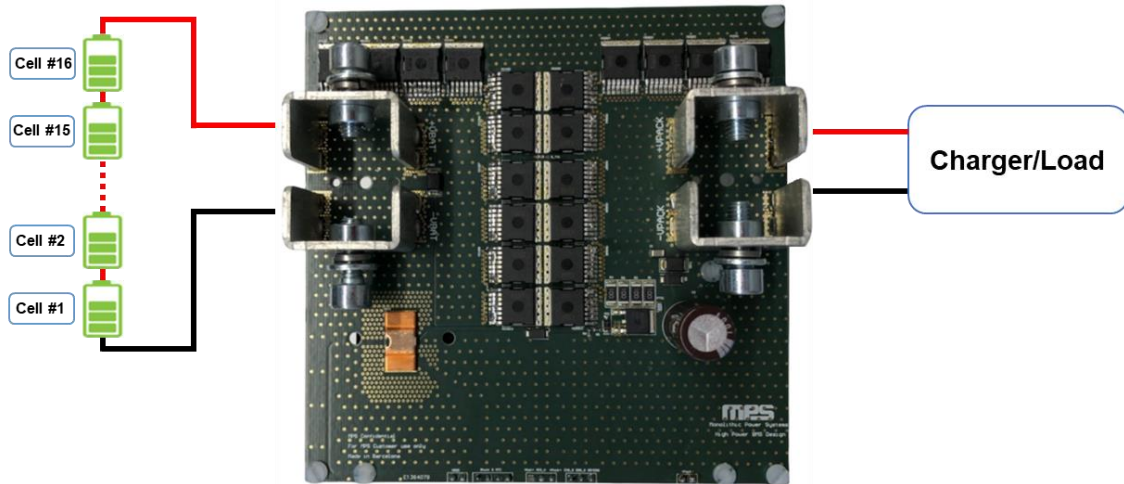

Figure 2: RVBMU1xx-R-01A Power Board

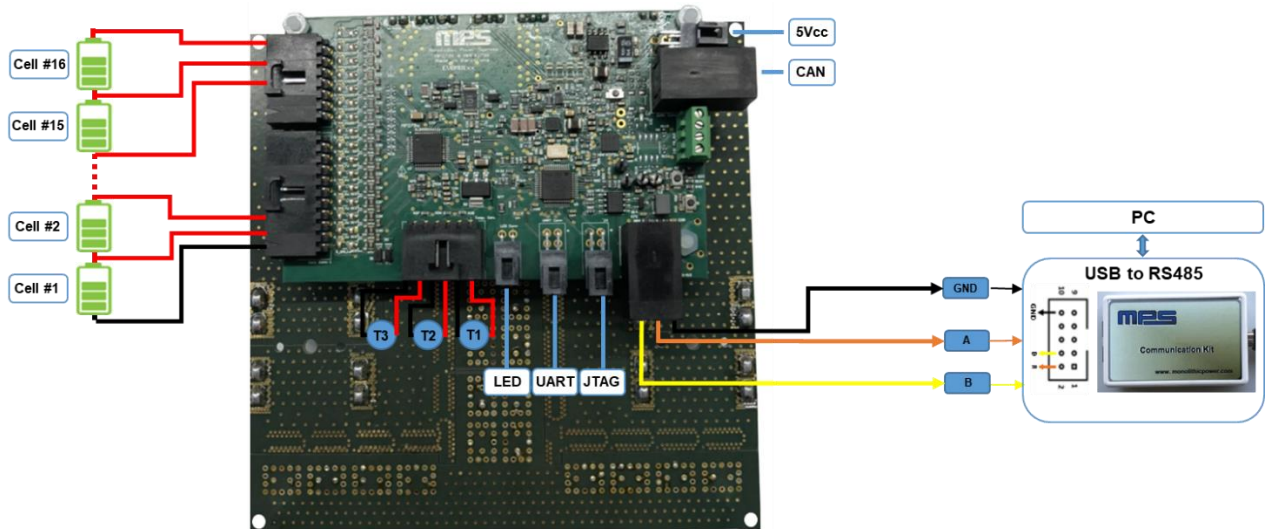

Figure 3: EVBMU1xx-R-01A Control Board

REVISION HISTORY

Revision #	Revision Date	Description	Pages Updated
1.0	6/1/2022	Initial Release	-

Notice: The information in this document is subject to change without notice. Please contact MPS for current specifications. Users should warrant and guarantee that third-party Intellectual Property rights are not infringed upon when integrating MPS products into any application. MPS will not assume any legal responsibility for any said applications.