

To check the correct PN of MOSFETs

VSP capacitors as close as possible to VSP pin

short traces for VSW to be close to IC

ISNS and VSNS as close as possible to their pins

To be optimized when EMI filters

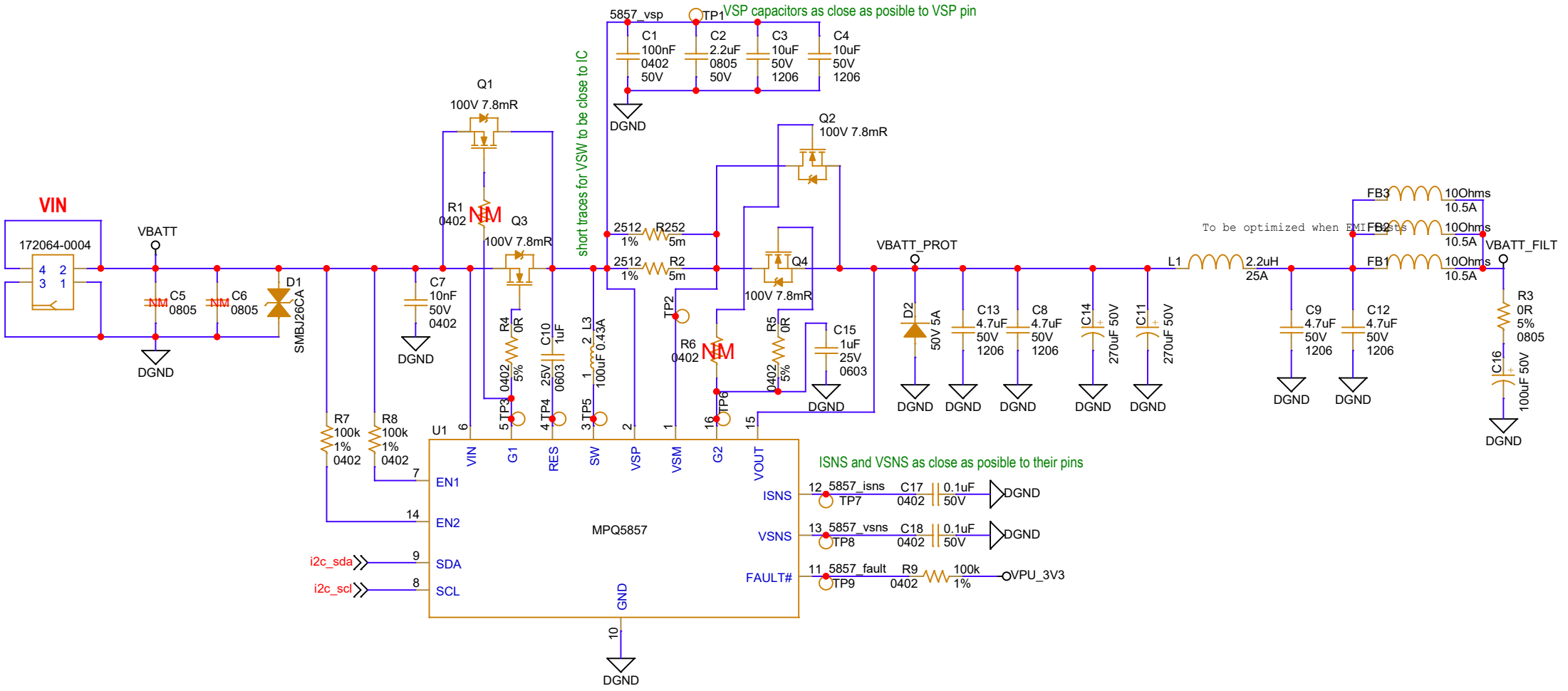

<b>Monolithic Power Systems</b>		<a href="http://www.monolithicpower.com">www.monolithicpower.com</a>	
<b>Title:</b> Versal Gen 2 Reference Design			
<b>Page:</b> 01) MPQ5857		<b>Checked by:</b> Xavier Ribas	
<b>Size:</b> A4	<b>Document:</b> MPQ5857	<b>Designed by:</b> Ariadna Romero	<b>Rev:</b> 1
<b>Date:</b> Wednesday, July 16, 2025		<b>Sheet:</b> 1 of 16	

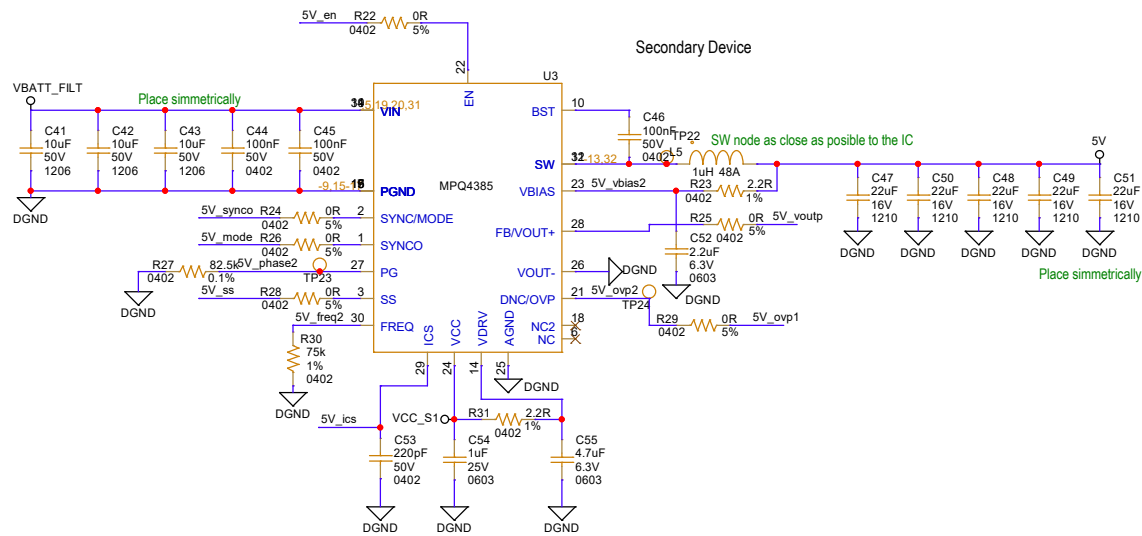
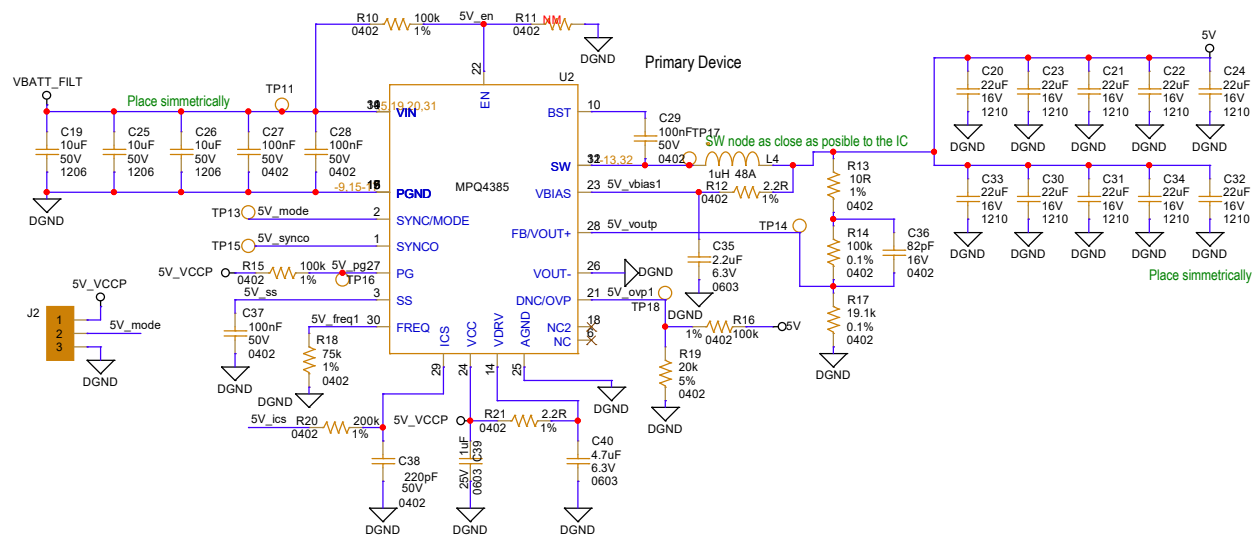

Monolithic Power Systems				www.monolithicpower.com
Title: Versal Gen 2 Reference Design				
Page: 02) MPQ4385	Checked by: Xavier Ribas			
Size: A3	Document: MPQ4385	Designed by: Ariadna Romero	Rev: 1	
Date: Wednesday, July 16, 2025	Sheet: 2 of 16			

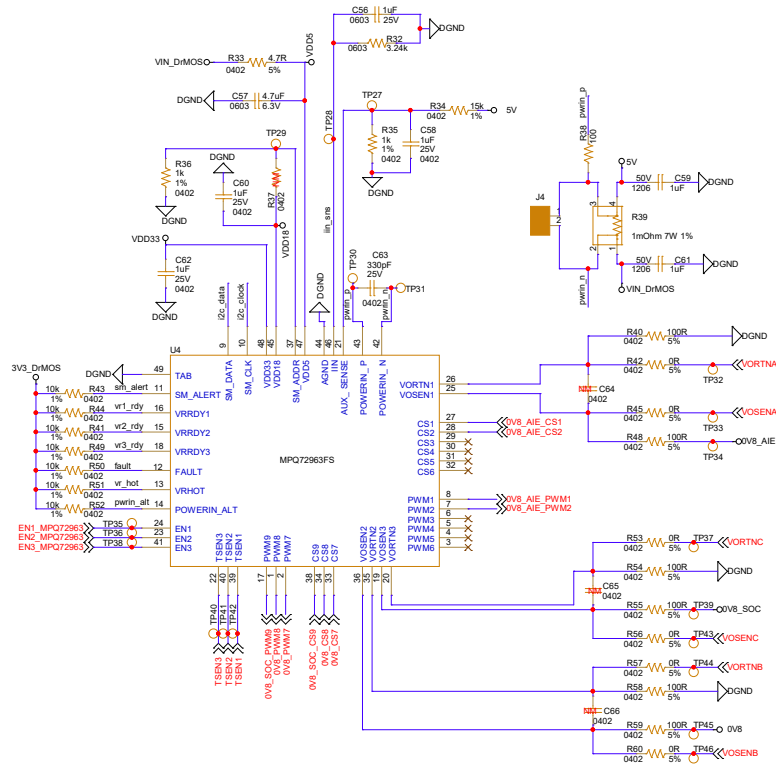
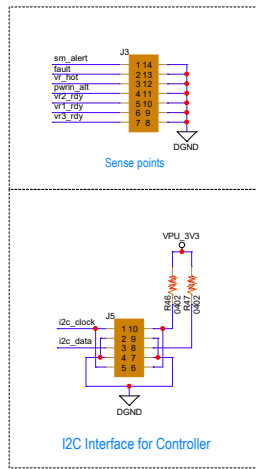

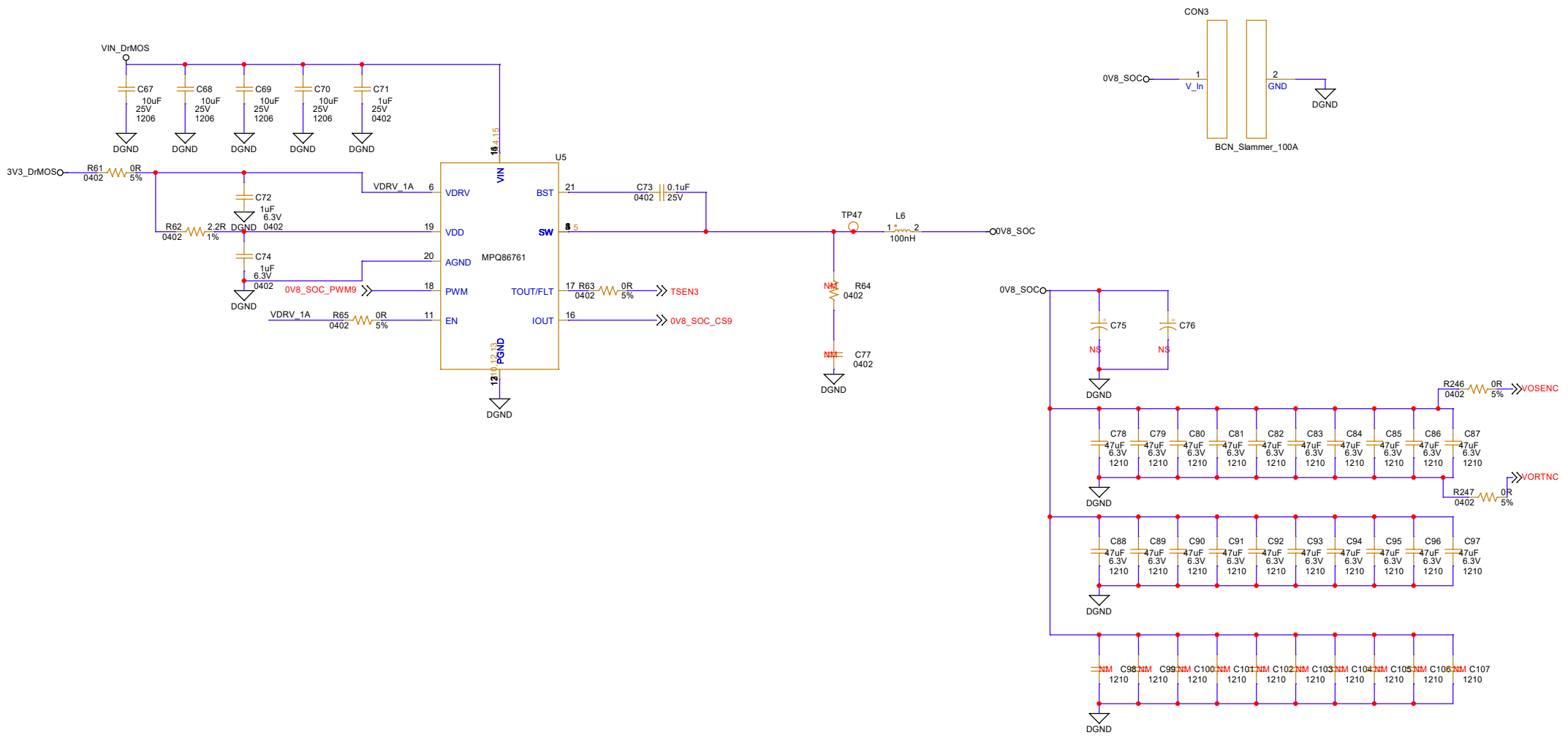

Monolithic Power Systems		www.monolithicpower.com	
Title: <Title>			
Page: 04) MPQ86761_0V8_SOC_30A		Checked by: <Checked by>	
Size: A3	Document: <Doc>	Designed by: <OrgAddr4>	Rev: <RevCode>
Date: Wednesday, July 16, 2025	Sheet: 4 of 16		

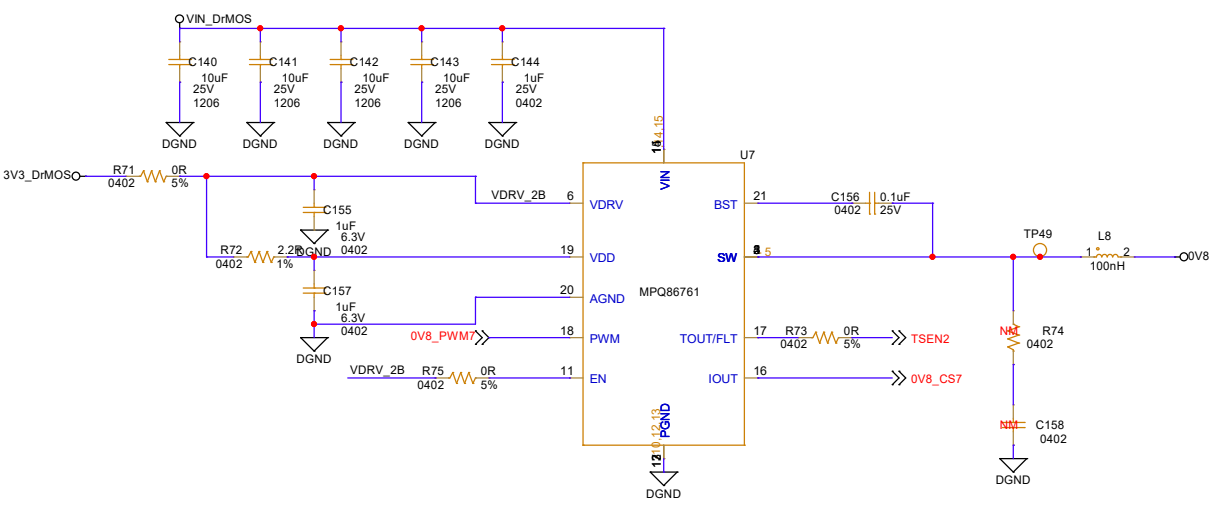
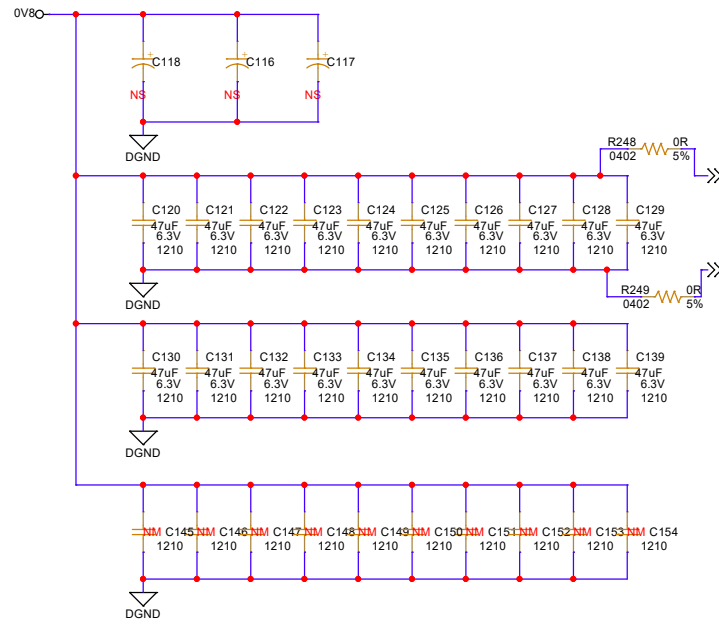
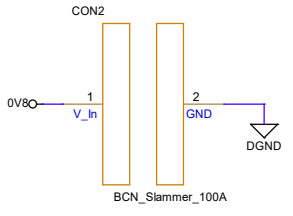
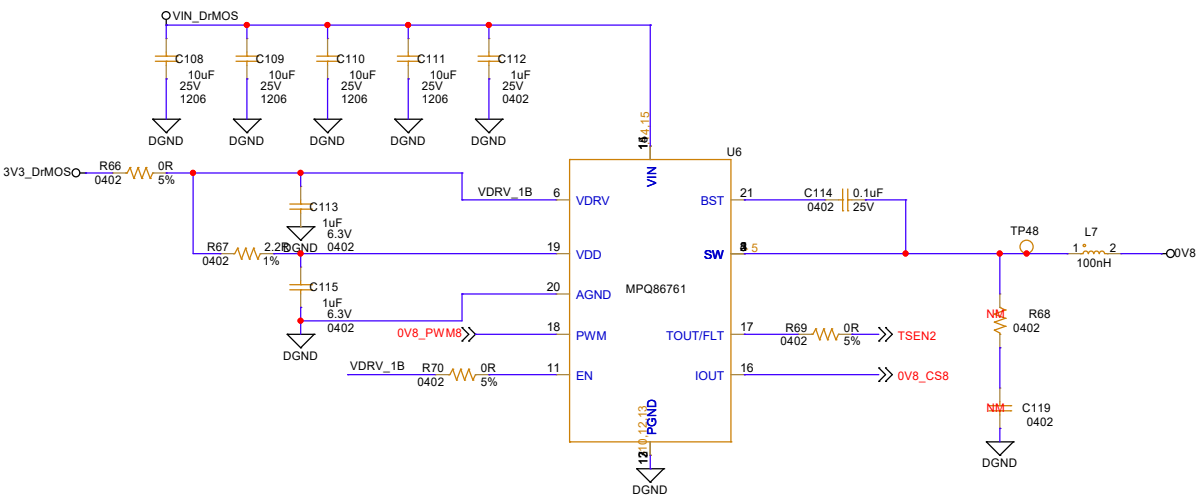

Monolithic Power Systems		www.monolithicpower.com	
Title: <Title>			
Page: 05) MPQ86761_OV8_37A		Checked by: <Checked by>	
Size: A3	Document: <Doc>	Designed by: <OrgAddr4>	Rev: <RevCode>
Date: Wednesday, July 16, 2025	Sheet: 5 of 16		

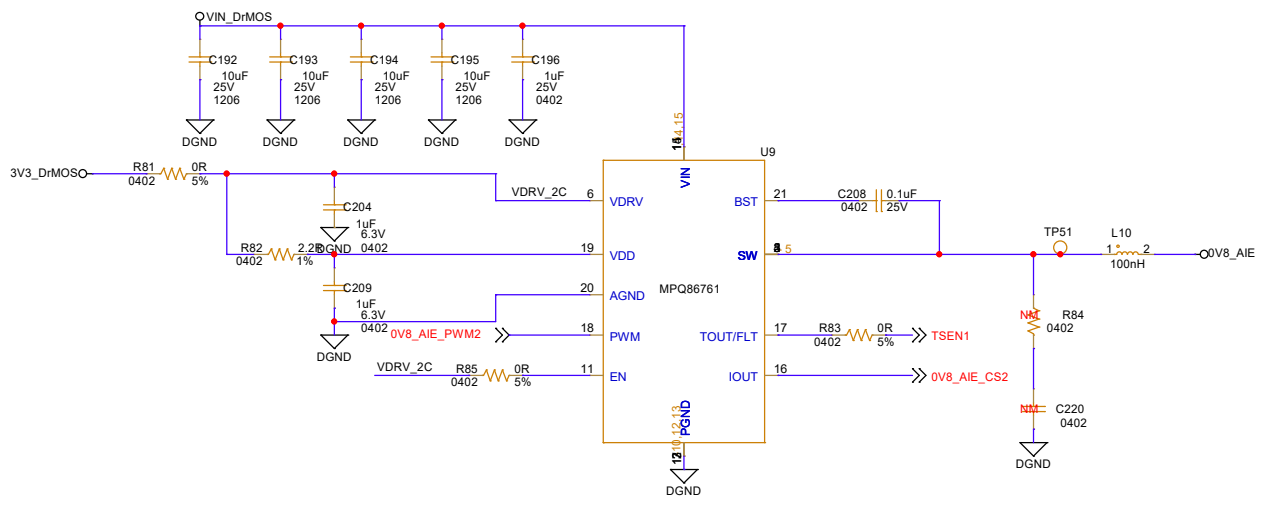
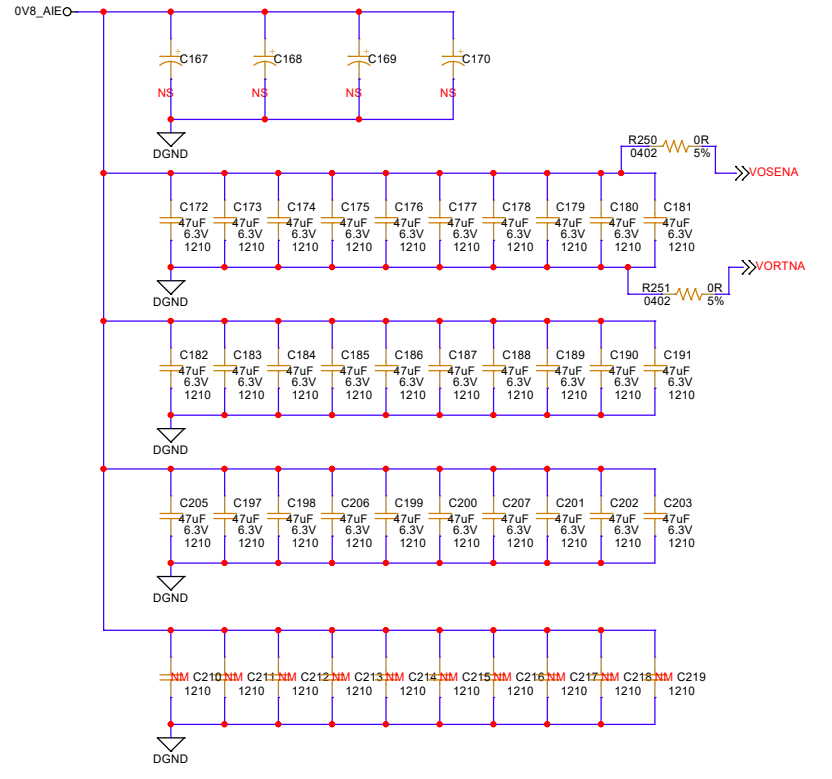
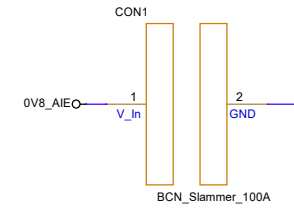
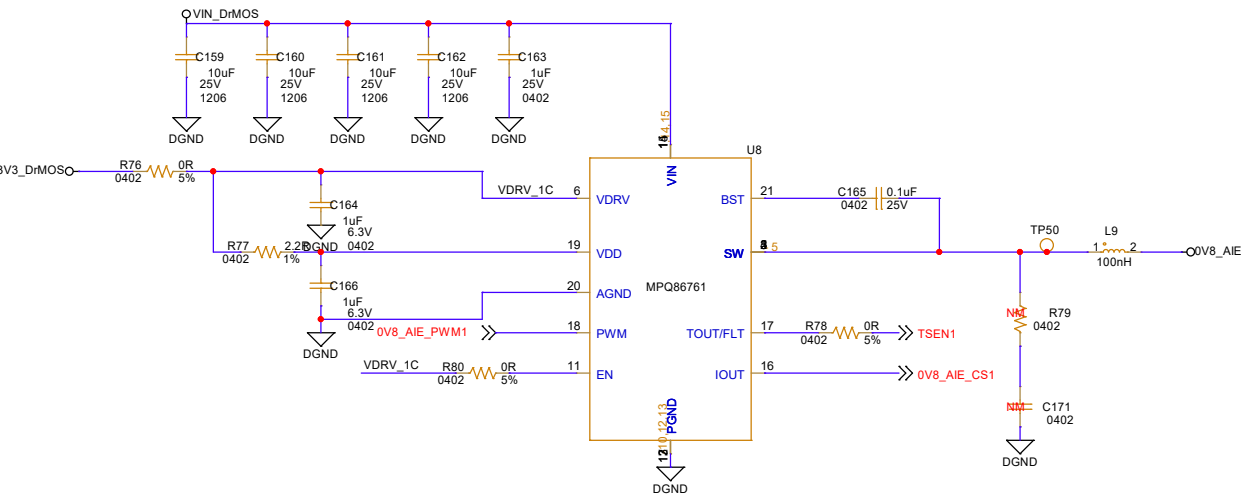

Monolithic Power Systems		www.monolithicpower.com	
Title: <Title>			
Page: 06) MPQ86761_0V8_AIE_60A		Checked by: <Checked by>	
Size: A3	Document: <Doc>	Designed by: <OrgAddr4>	Rev: <RevCode>
Date: Wednesday, July 16, 2025	Sheet: 6 of 16		

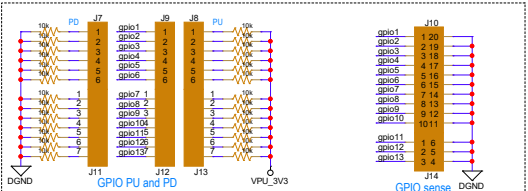
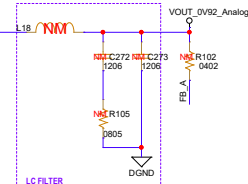
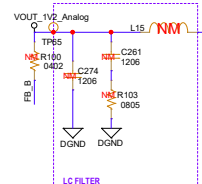
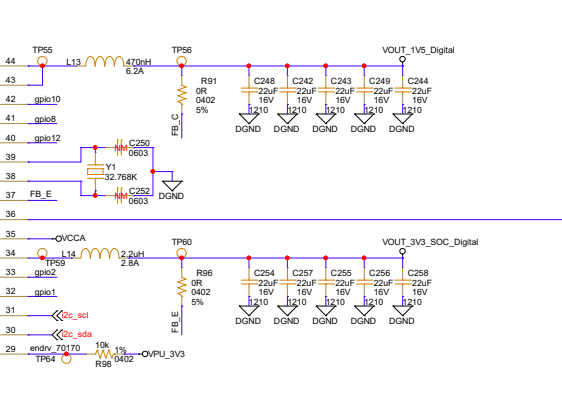
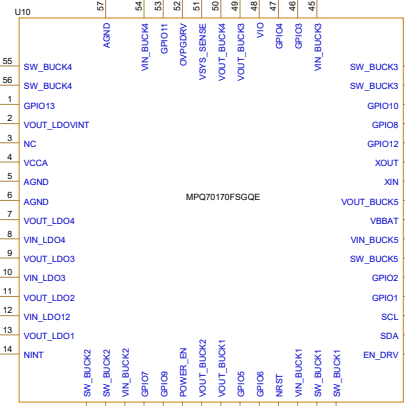
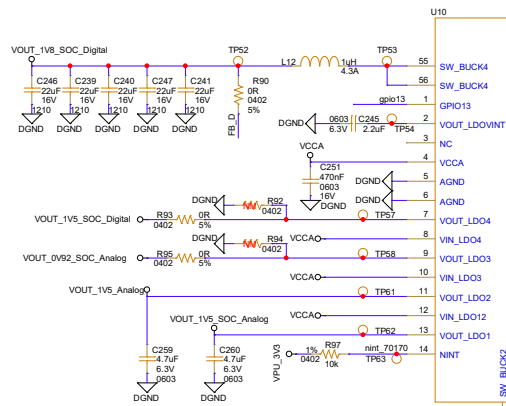
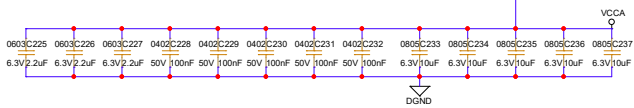
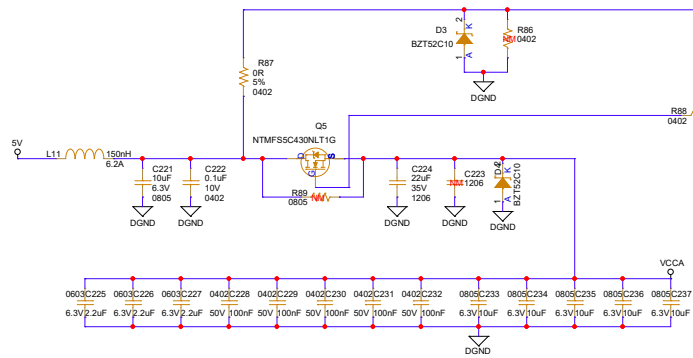

- EN1\_MPQ72963 gpi01
- EN2\_MPQ72963 gpi02
- EN3\_MPQ72963 gpi03
- PMIC\_EN\_1V8\_SOC\_Digital gpi04
- PMIC\_EN\_0V92\_SOC\_Analog gpi05
- PMIC\_EN\_1V5\_SOC\_Analog gpi06
- PMIC\_EN\_3V3\_Digital gpi07
- PMIC\_EN\_1V8\_Digital gpi08
- PMIC\_PG\_BK1 gpi09
- PMIC\_PG\_BK2 gpi10
- PMIC\_PG\_BK3 gpi11
- PMIC\_PG\_BK4 gpi12
- PMIC\_PG\_BK5 gpi13

**MPS**  
Monolithic Power Systems  
www.monolithicpower.com

**Title:** Versal Gen 2 Reference Design  
**Page:** 07 | MPQ70170FS  
**Size:** Document  
**Date:** Wednesday, July 16, 2025

**Checked by:** Xavier Ribas  
**Designed by:** Arisdra Romero  
**Rvr:** 1  
**Sheet:** 7 of 16

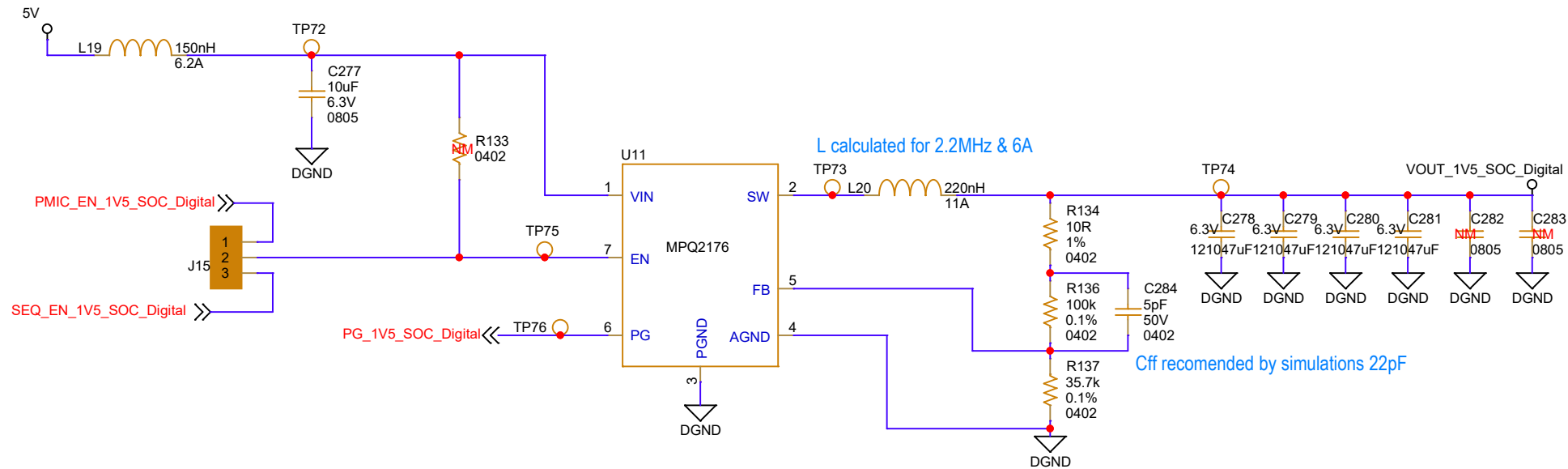

<b>Monolithic Power Systems</b>		<a href="http://www.monolithicpower.com">www.monolithicpower.com</a>	
<b>Title:</b> Versal Gen 2 Reference Design			
<b>Page:</b> 08) MPQ2176_1V5_6A		<b>Checked by:</b> Xavier Ribas	
<b>Size:</b> A4	<b>Document:</b> 1V5_SOC Digital	<b>Designed by:</b> Ariadna Romero	<b>Rev:</b> 1
<b>Date:</b> Friday, July 18, 2025		<b>Sheet:</b> 8 of 16	

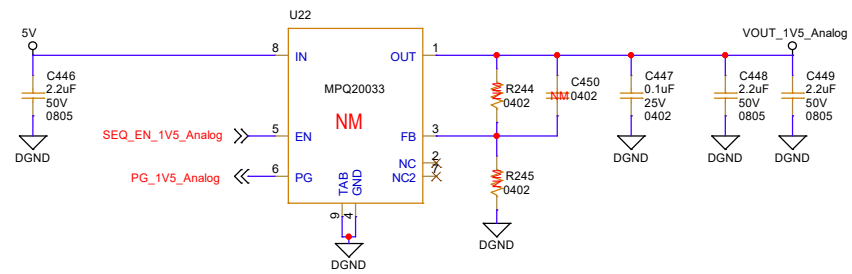

<b>Monolithic Power Systems</b>			
<a href="http://www.monolithicpower.com">www.monolithicpower.com</a>			
<b>Title:</b> Versal Gen 2 Reference Design			
<b>Page:</b> 17) MPQ20032		<b>Checked by:</b> Xavier Ribas	
<b>Size:</b> A3	<b>Document:</b> 1V8 Digital	<b>Designed by:</b> Ariadna Romero	<b>Rev:</b> 1
<b>Date:</b> Wednesday, July 16, 2025		<b>Sheet:</b> 12 of 16	

VDD 2.5V to 5.5V VDD capacitors as close as possible to VDD pin

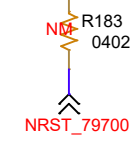
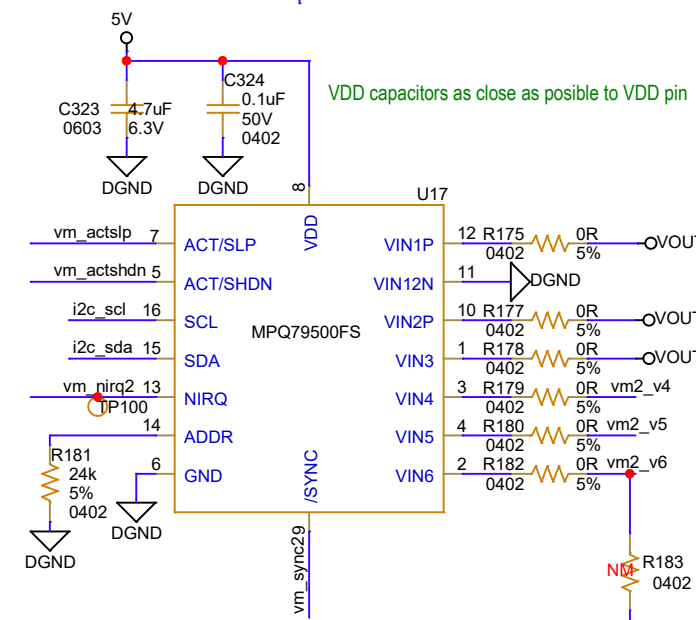
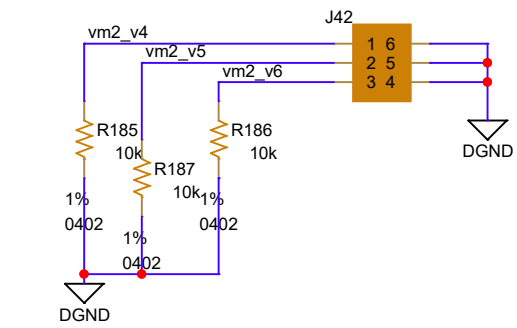
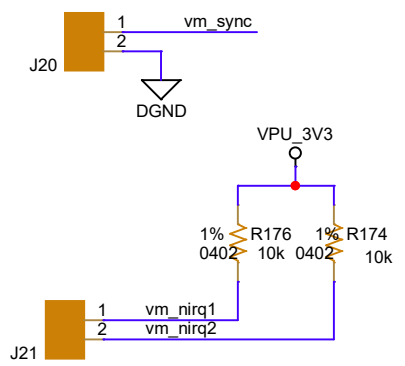
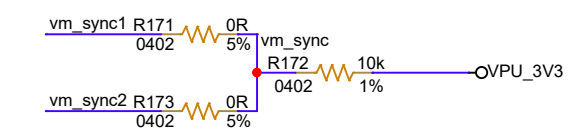
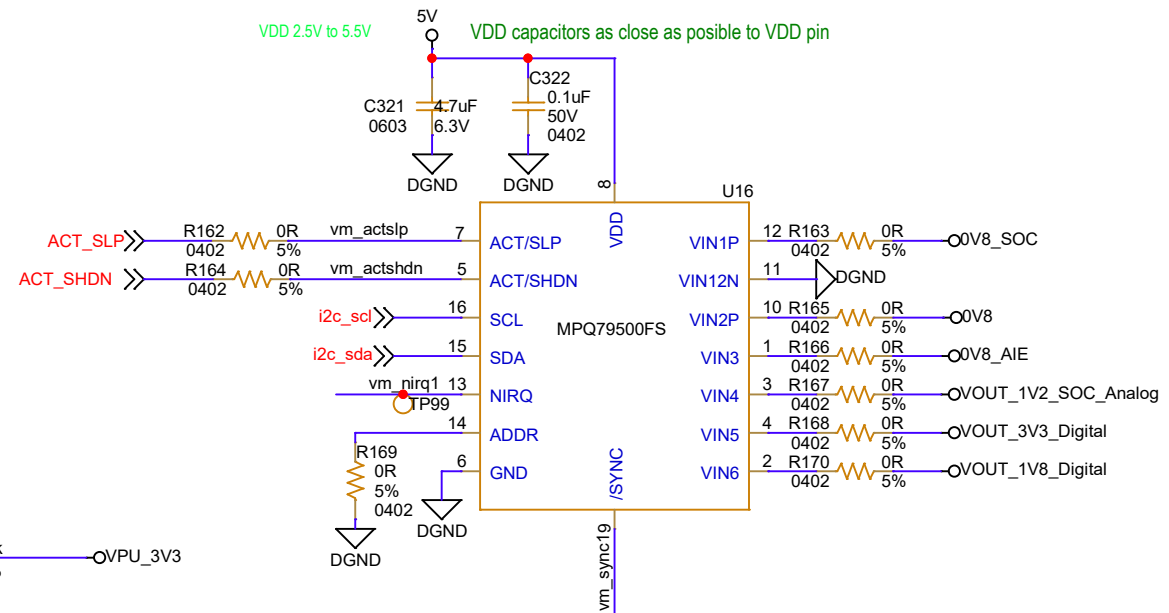

<b>Monolithic Power Systems</b>		<a href="http://www.monolithicpower.com">www.monolithicpower.com</a>	
Title: Versal Gen 2 Reference Design			
Page: 13) MPQ79500FS		Checked by: Xavier Ribas	
Size: A4	Document: Monitor MPQ79500FS	Designed by: Ariadna Romero	Rev: 1
Date: Wednesday, July 16, 2025	Sheet: 13 of 16		

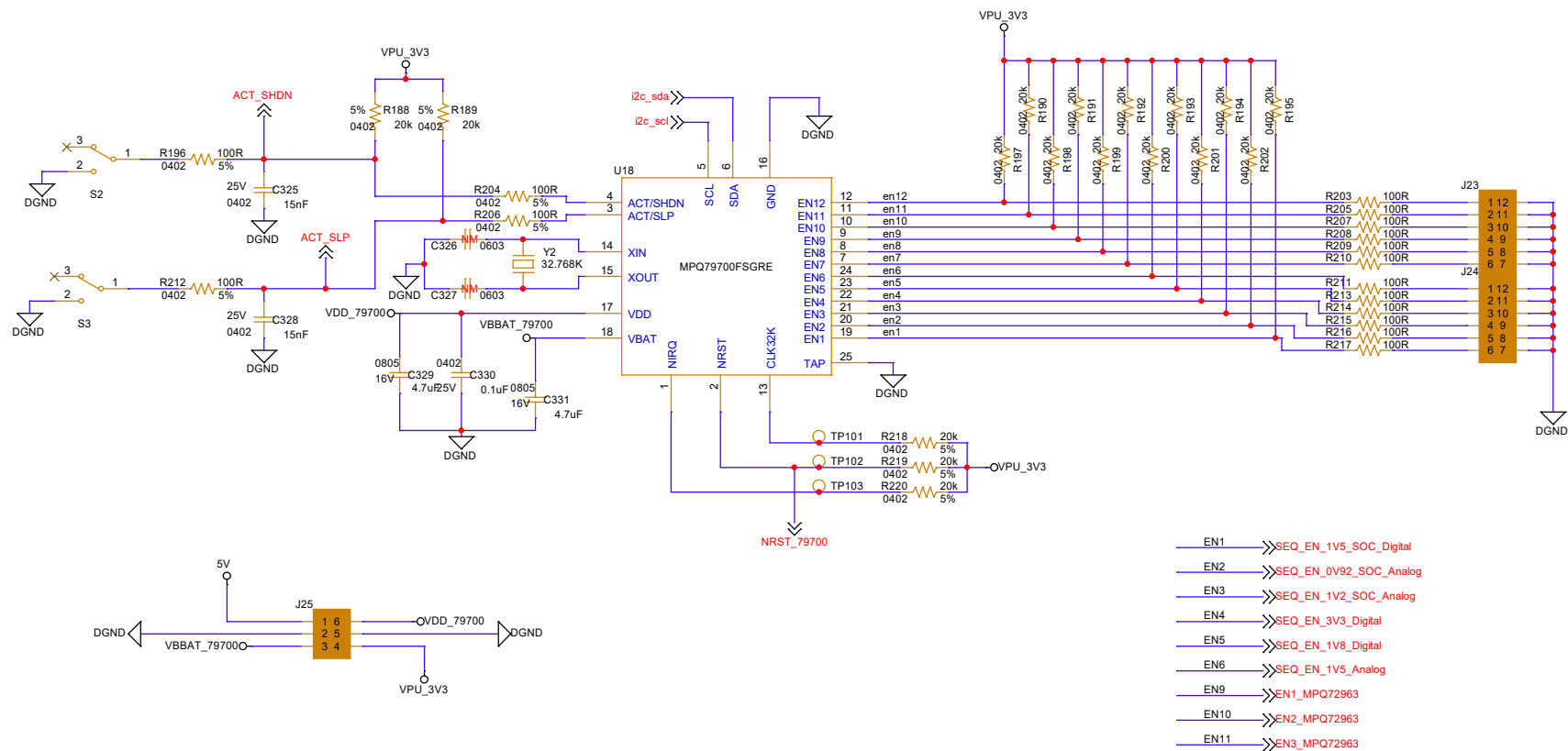

- EN1 >>> SEQ\_EN\_1V5\_SOC\_Digital
- EN2 >>> SEQ\_EN\_0V92\_SOC\_Analog
- EN3 >>> SEQ\_EN\_1V2\_SOC\_Analog
- EN4 >>> SEQ\_EN\_3V3\_Digital
- EN5 >>> SEQ\_EN\_1V8\_Digital
- EN6 >>> SEQ\_EN\_1V5\_Analog
- EN9 >>> EN1\_MPU72963
- EN10 >>> EN2\_MPU72963
- EN11 >>> EN3\_MPU72963



<b>Monolithic Power Systems</b>		<a href="http://www.monolithicpower.com">www.monolithicpower.com</a>	
Title: Versal Gen 2 Reference Design			
Page: 14)	MPQ79700FS_EN	Checked by:	Xavier Ribas
Size: A3	Document: Squencer MPQ79700FS	Designed by:	Ariadna Romero
Date: Wednesday, July 16, 2025	Sheet:	14 of 16	

# VE3858 SOC Mode Board Capacitance

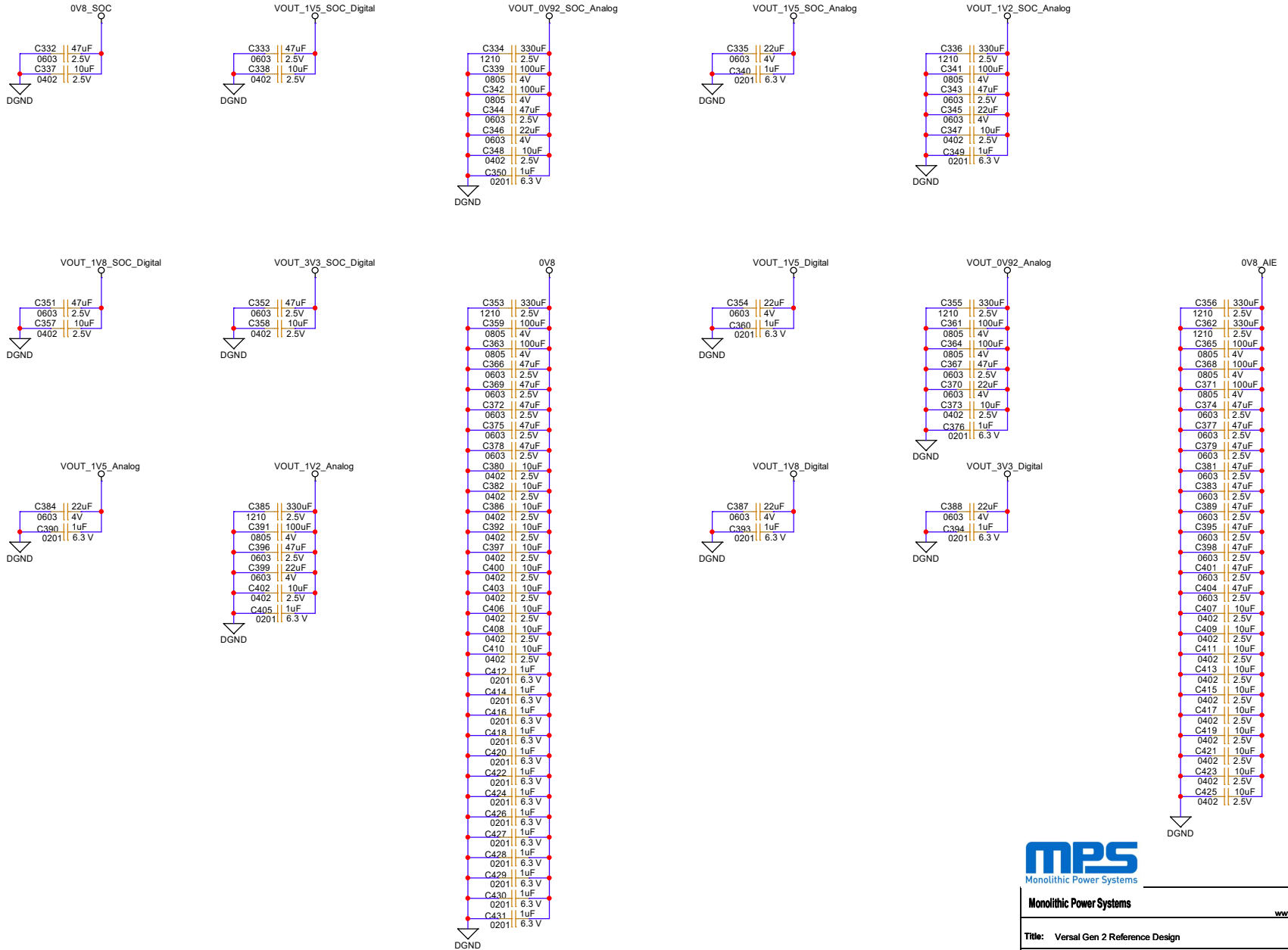

<b>Monolithic Power Systems</b> www.monolithicpower.com			
Title: Versal Gen 2 Reference Design			
Page: 15) VDD_CAPS	Checked by: Xavier Ribas		
Size: A3	Document: VDD Capacitors	Designed by: Ariadna Romero	Rev: 1
Date: Wednesday, July 16, 2025	Sheet: 15 of 16		

# AUXILIAR CONNECTORS

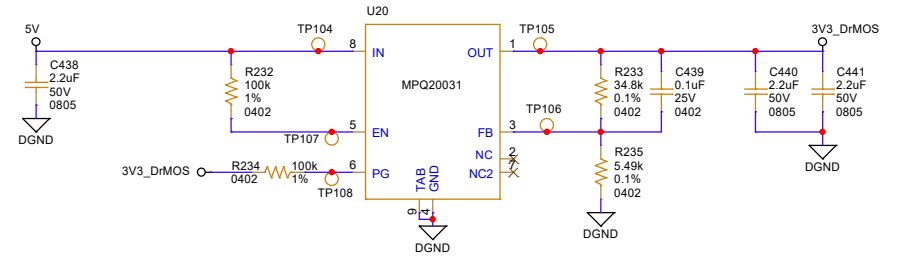
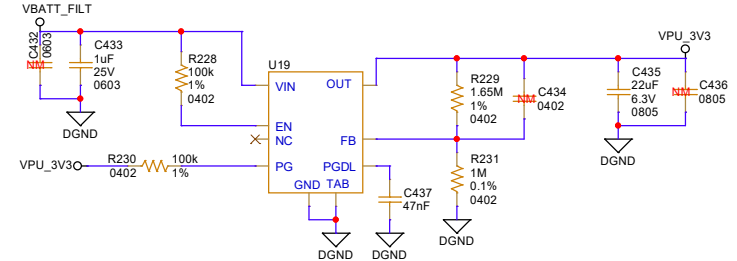
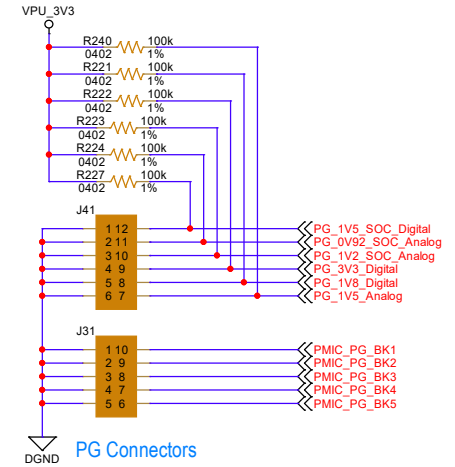
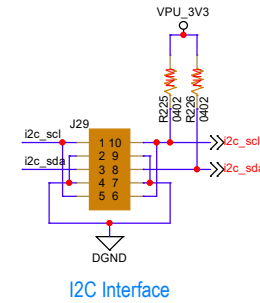
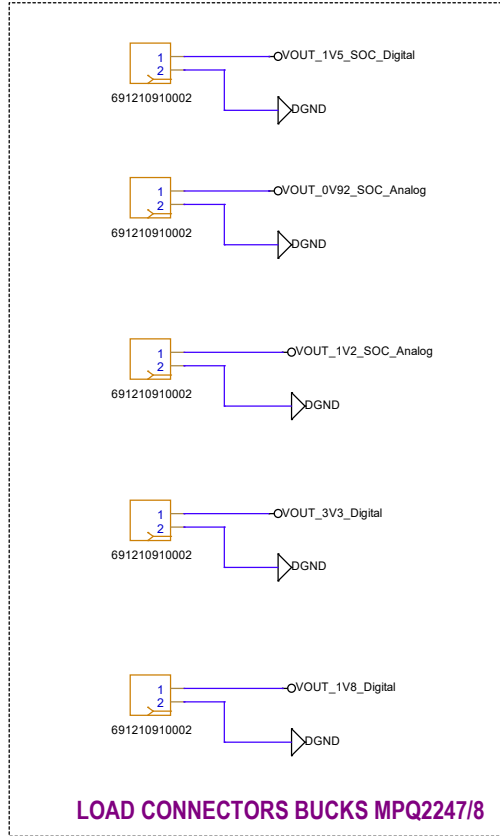
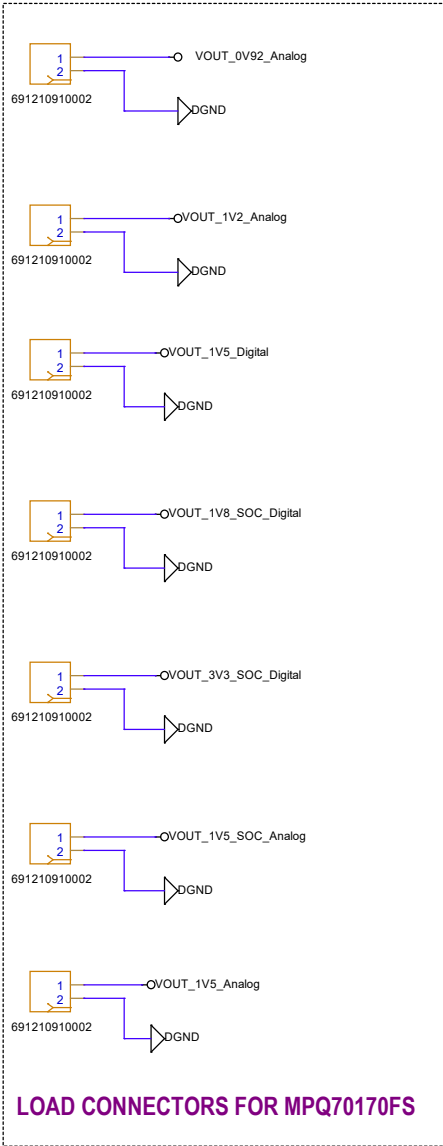

Monolithic Power Systems				www.monolithicpower.com
Title: Versal Gen 2 Reference Design				
Page: 16) CONNECTORS			Checked by: Xavier Ribas	
Size: A3	Document: Connectors	Designed by: Ariadna Romero	Rev: 1	
Date: Wednesday, July 16, 2025	Sheet: 16 of 16			

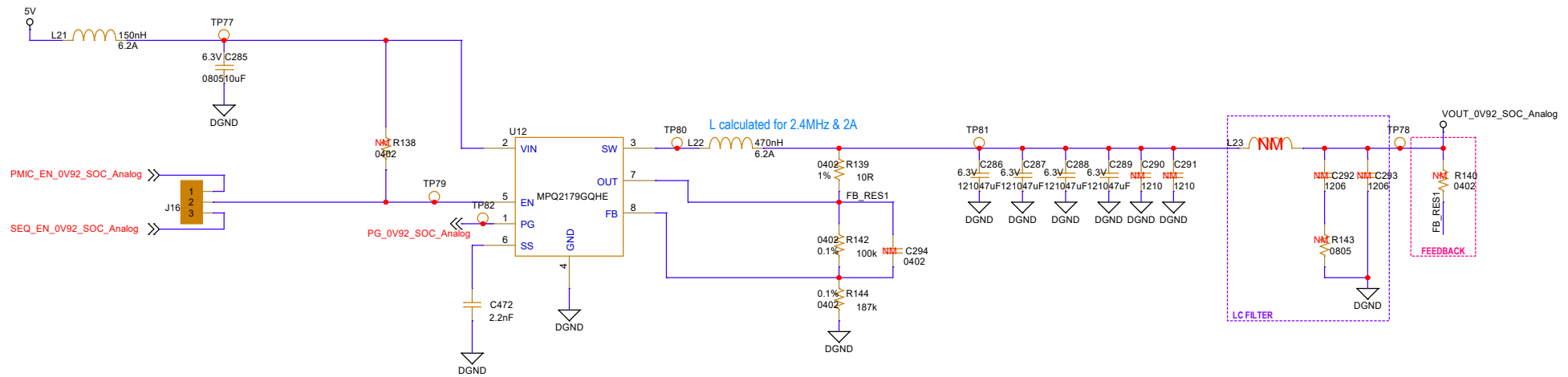

Monolithic Power Systems		www.monolithicpower.com	
Title: <Title>			
Page: 09) MPQ2179_0V92_2A		Checked by: <Checked by>	
Size: A3	Document: <Doc>	Designed by: <OrgAddr4>	Rev: <RevCode>
Date: Friday, July 18, 2025	Sheet: 18 of 21		

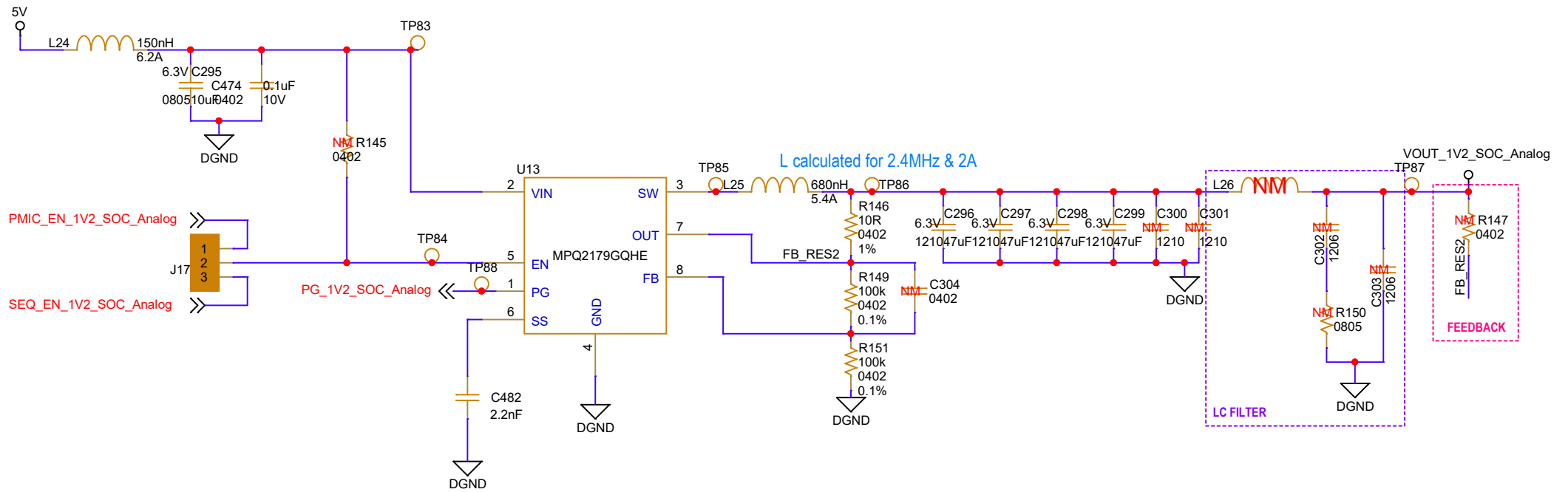

<b>Monolithic Power Systems</b>		<a href="http://www.monolithicpower.com">www.monolithicpower.com</a>	
Title: <Title>			
Page: 10) MPQ2179_1V2_2A		Checked by: <Checked by>	
Size: A4	Document: <Doc>	Designed by: <OrgAddr4>	Rev: <RevCode>
Date: Monday, July 21, 2025	Sheet: 19 of 21		

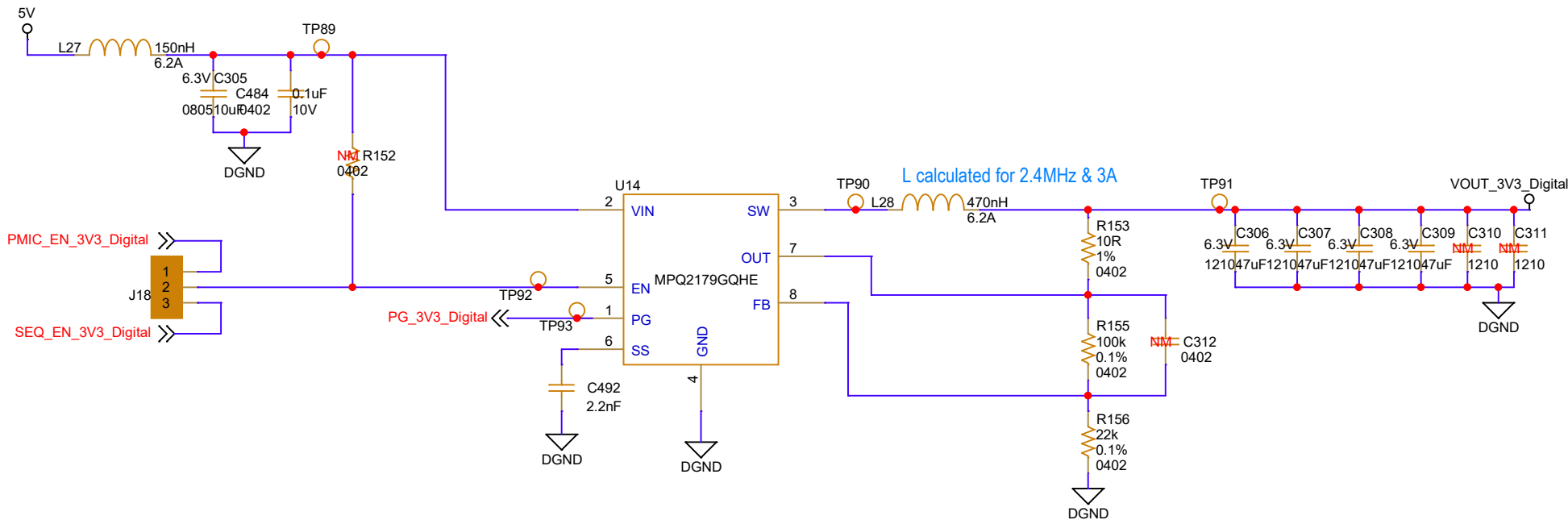

<b>Monolithic Power Systems</b>		<a href="http://www.monolithicpower.com">www.monolithicpower.com</a>	
Title: <Title>			
Page: 11) MPQ2179_3V3_3A		Checked by: <Checked by>	
Size: A4	Document: <Doc>	Designed by: <OrgAddr4>	Rev: <RevCode>
Date: Monday, July 21, 2025	Sheet: 20 of 21		

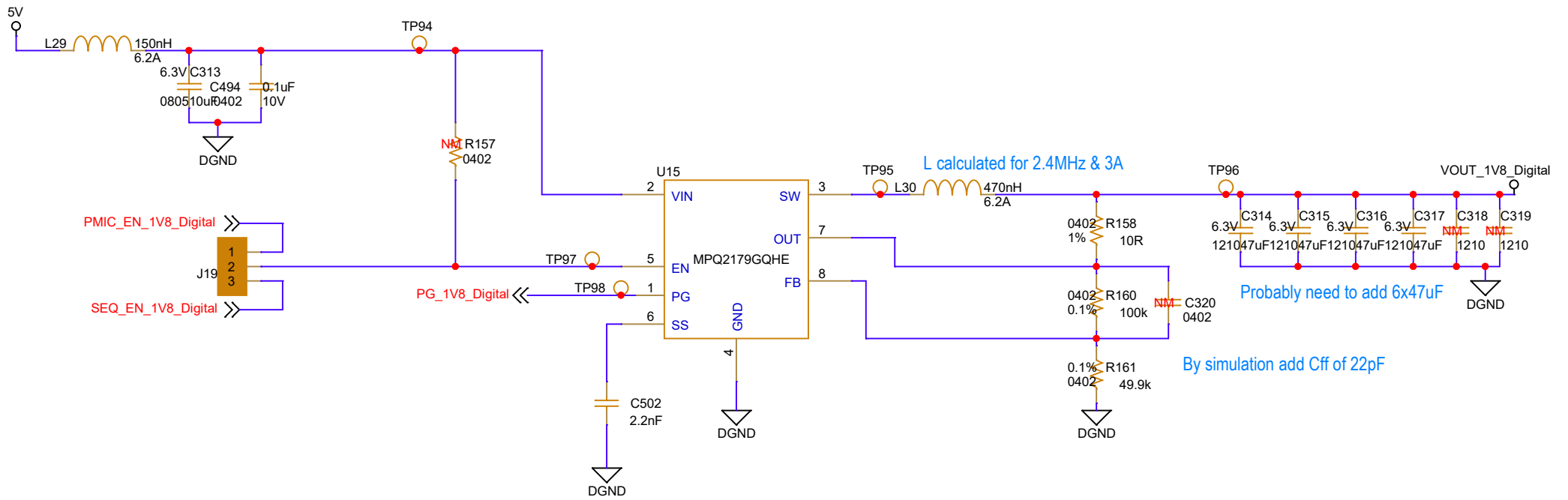

<b>Monolithic Power Systems</b>		<a href="http://www.monolithicpower.com">www.monolithicpower.com</a>	
Title: <Title>			
Page: 12) MPQ2179_1V8_3A		Checked by: <Checked by>	
Size: A4	Document: <Doc>	Designed by: <OrgAddr4>	Rev: <RevCode>
Date: Monday, July 21, 2025		Sheet: 21 of 21	