

***Xilinx Reference Design Test Report***  
***---EVREF0101-A/B***

*June, 2018*

Vin 12V

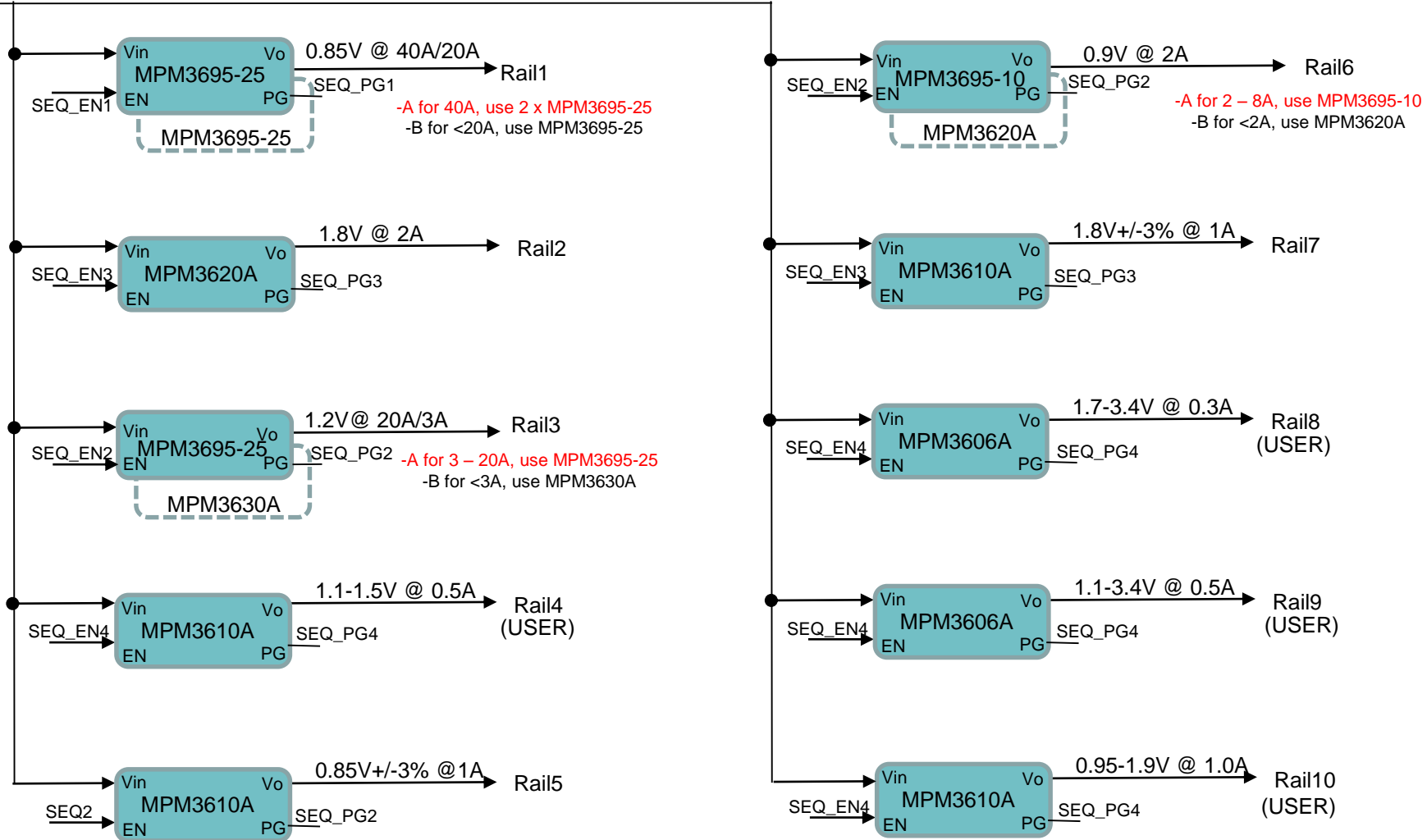

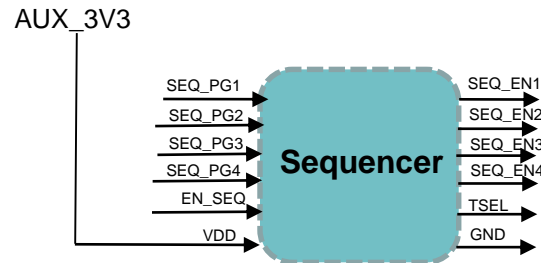
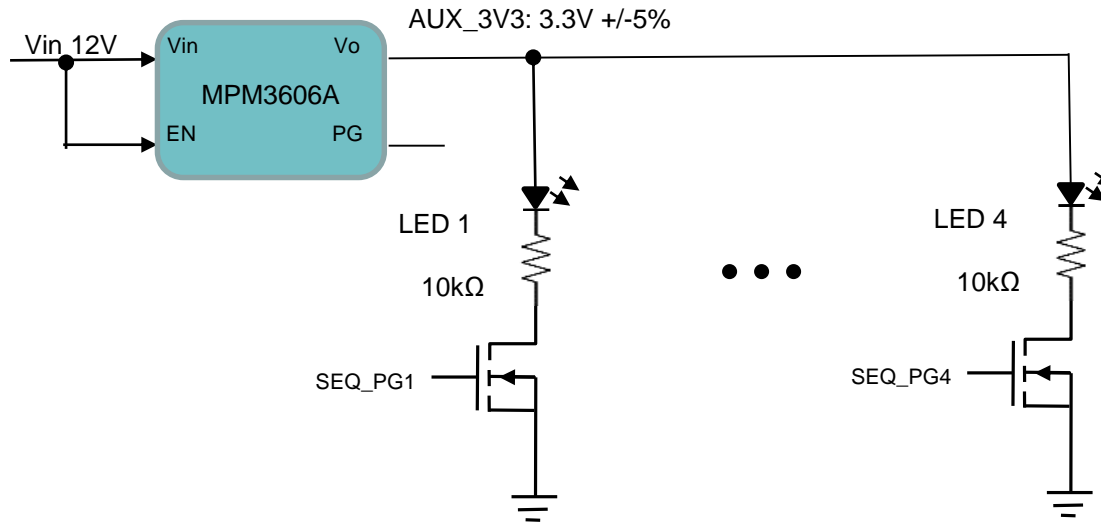

Rail Number	Rail Voltage	Rail Current	Part Number
1	0.85V	3A - 40A	MPM3695-25 x 2
2	1.8V	0A - 2A	MPM3620A
3	1.2V	3A - 20A	MPM3695-25
4	1.1V-1.5V	0A - 1A	MPM3610A
5	0.85V	0A - 1A	MPM3610A
6	0.9V	2A - 8A	MPM3695-10
7	1.8V	0A - 1A	MPM3610A
8	1.7V - 3.4V	0A - 0.6A	MPM3606A
9	1.1V - 3.4V	0A - 0.6A	MPM3606A
10	0.95V - 1.9V	0A - 1A	MPM3610A

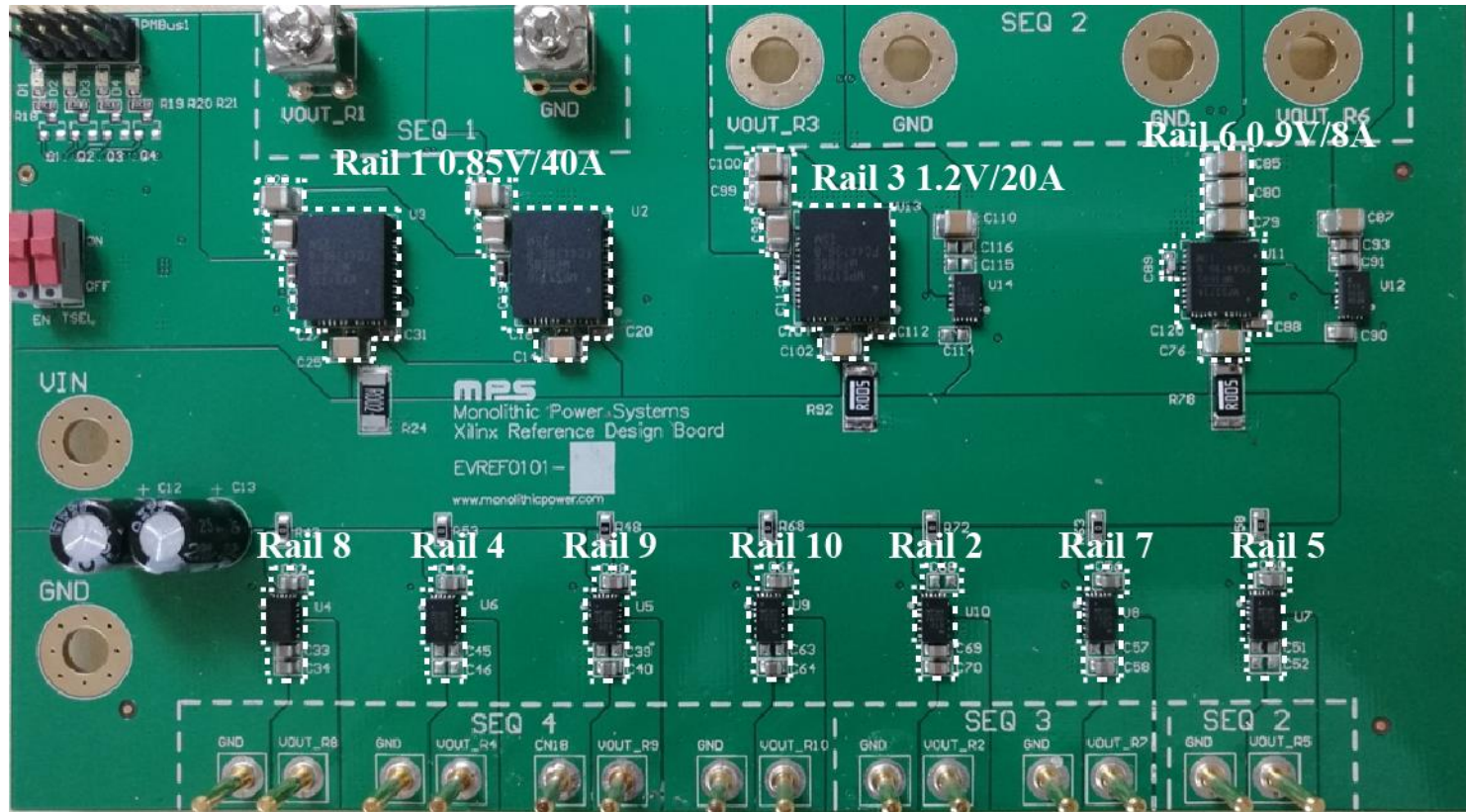

**Total of 10 Output Rails**

Rail Number	Rail Voltage	Rail Current	Part Number
1	0.85V	3A - 20A	MPM3695-25 x 1
2	1.8V	0A - 2A	MPM3620A
3	1.2V	0A - 3A	MPM3630A
4	1.1V-1.5V	0A - 1A	MPM3610A
5	0.85V	0A - 1A	MPM3610A
6	0.9V	0A - 2A	MPM3620A
7	1.8V	0A - 1A	MPM3610A
8	1.7V - 3.4V	0A - 0.6A	MPM3606A
9	1.1V - 3.4V	0A - 0.6A	MPM3606A
10	0.95V - 1.9V	0A - 1A	MPM3610A

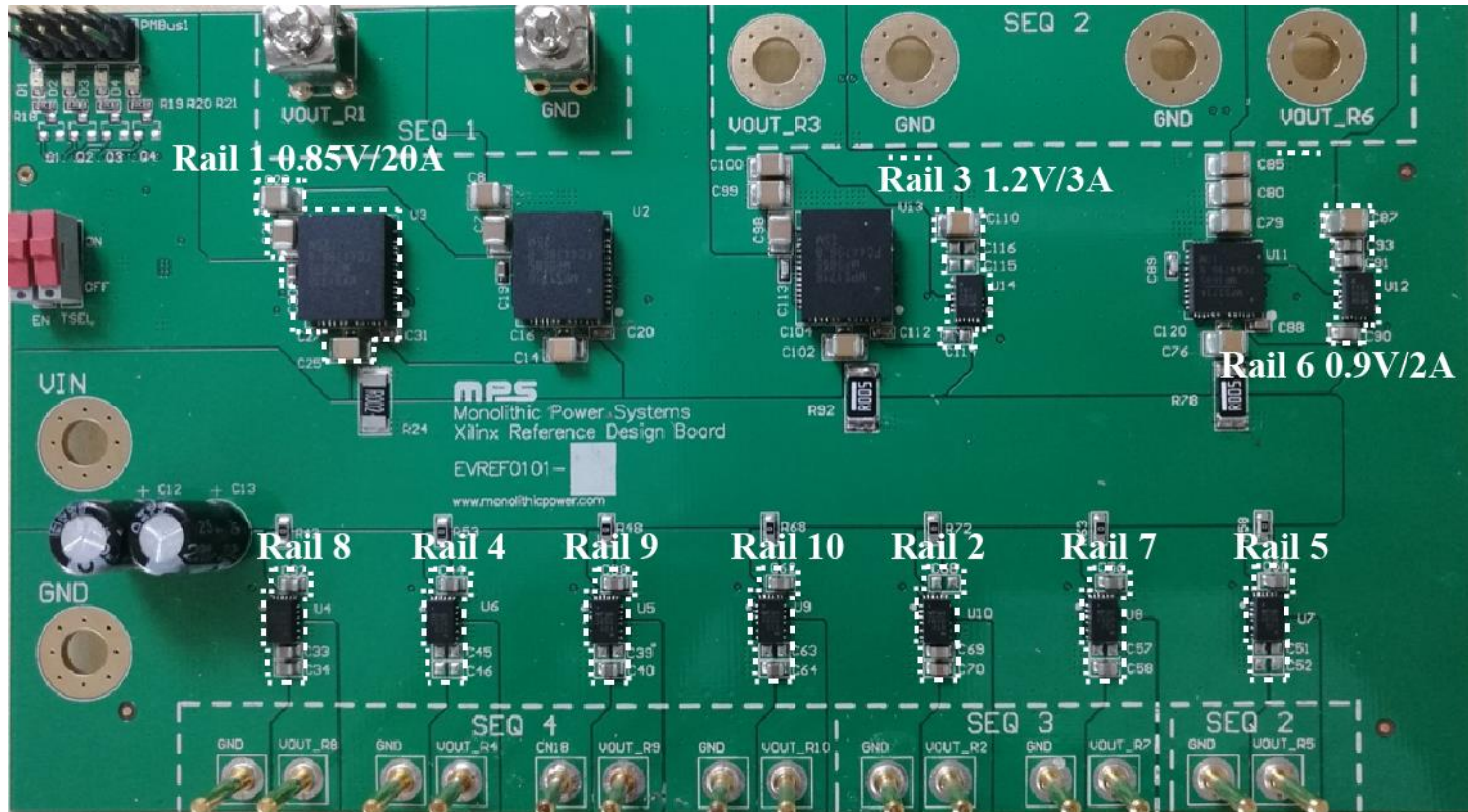

**Total of 10 Output Rails**



## Start UP

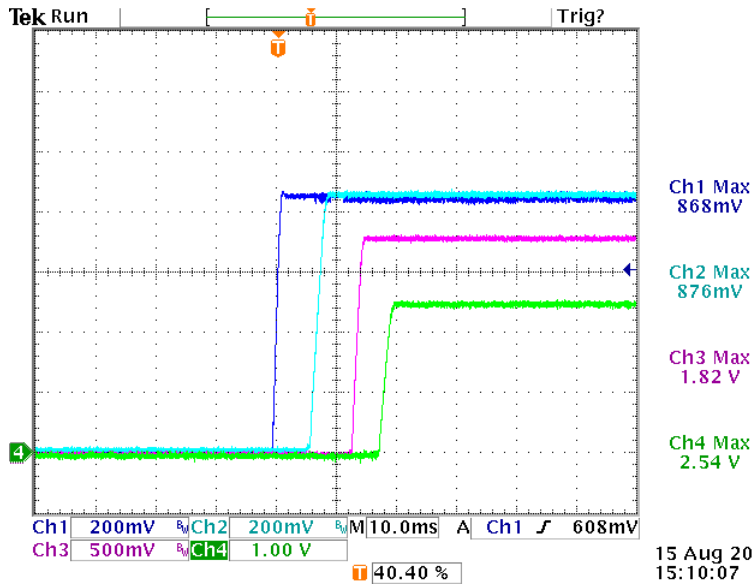

SEQ1 SEQ2 SEQ3 SEQ4

## Shut Down

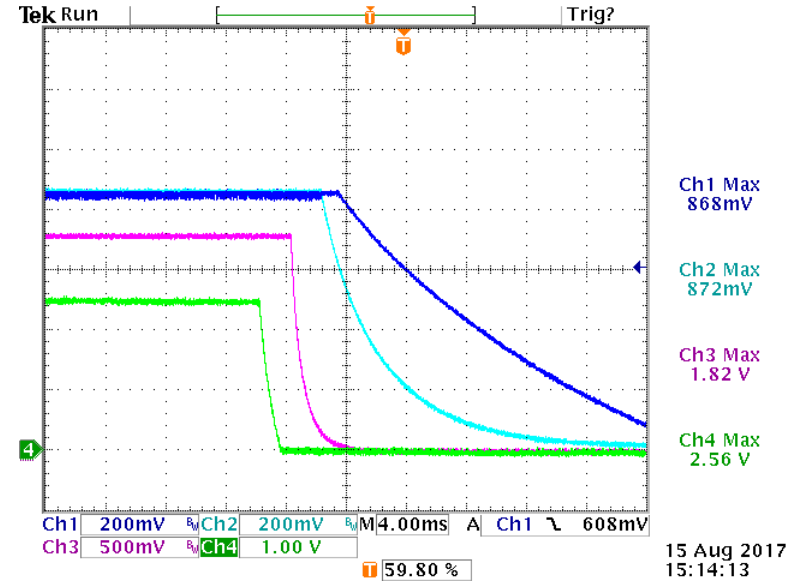



2 Phase MPM3695-25, VIN=12V, VOUT=0.85V, COUT=4 x 100uF per phase

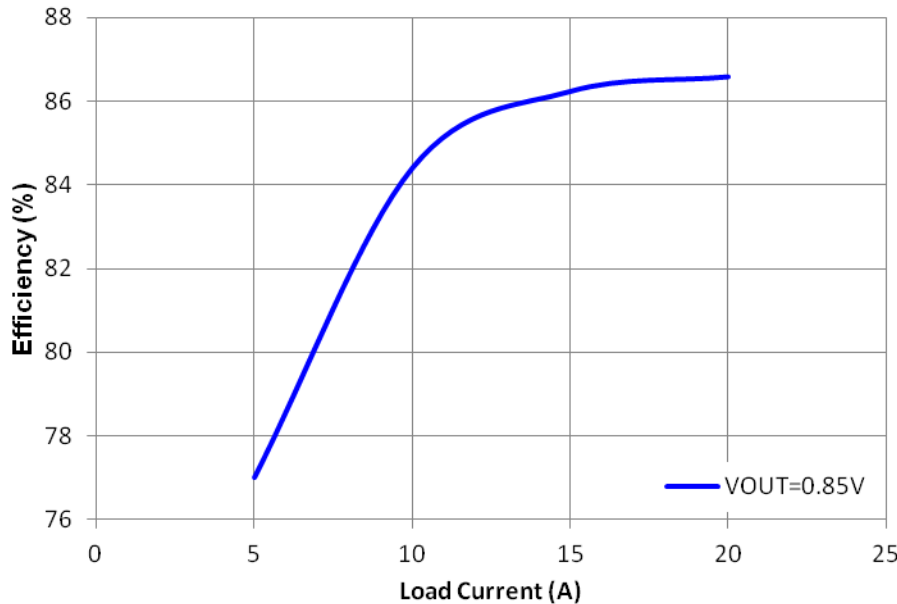

**Max Efficiency 86.6%**

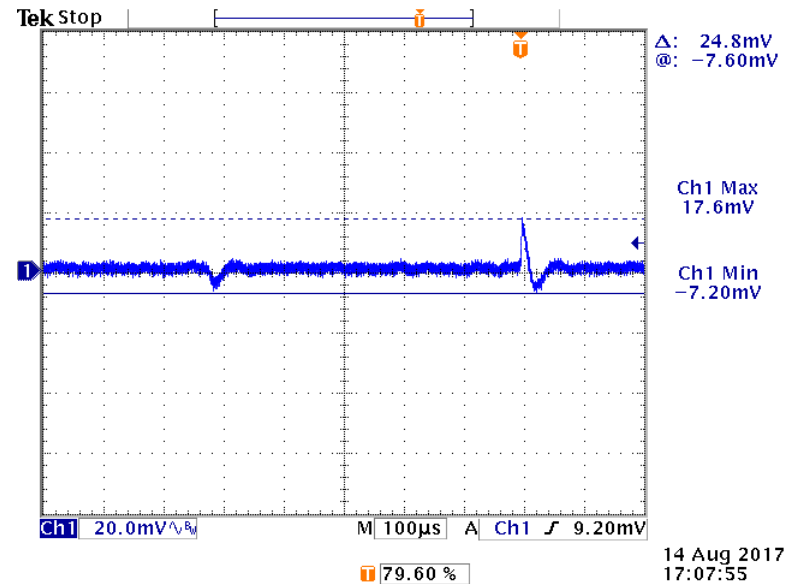

**Vpp = 24.8mV, less than ±2% of VOUT @5A/us, 10A to 20A**

2 Phase MPM3695-25, VIN=12V, VOUT=0.85V, COUT=4 x 100uF per phase

IO=0A

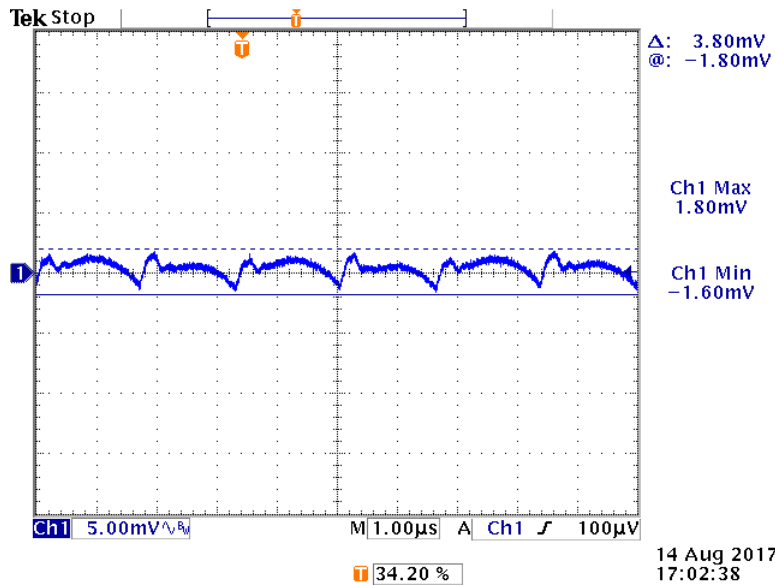

IO=20A

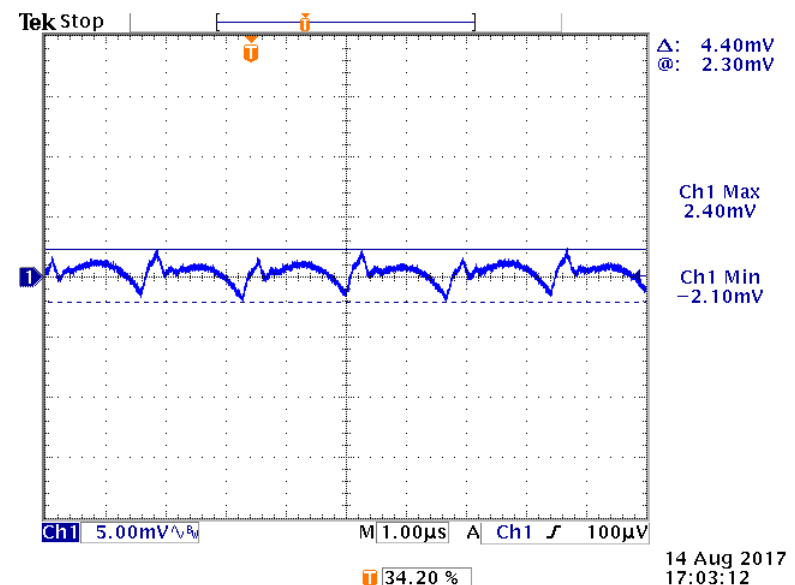

Max Vpp = 4.4mV, around 0.5% of VOUT

MPM3620A, VIN=12V, VOUT=1.8V, COUT=22\*2uF

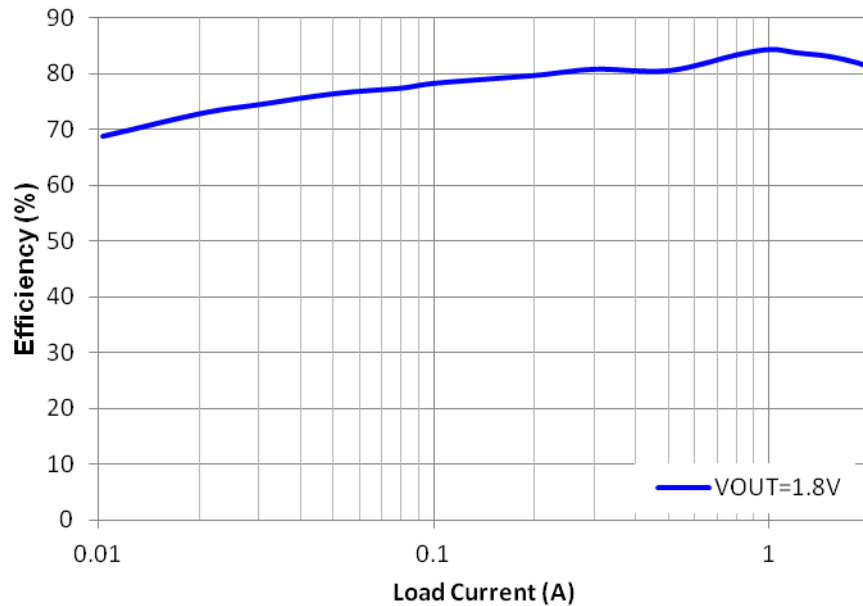

**Max Efficiency 84.3%**

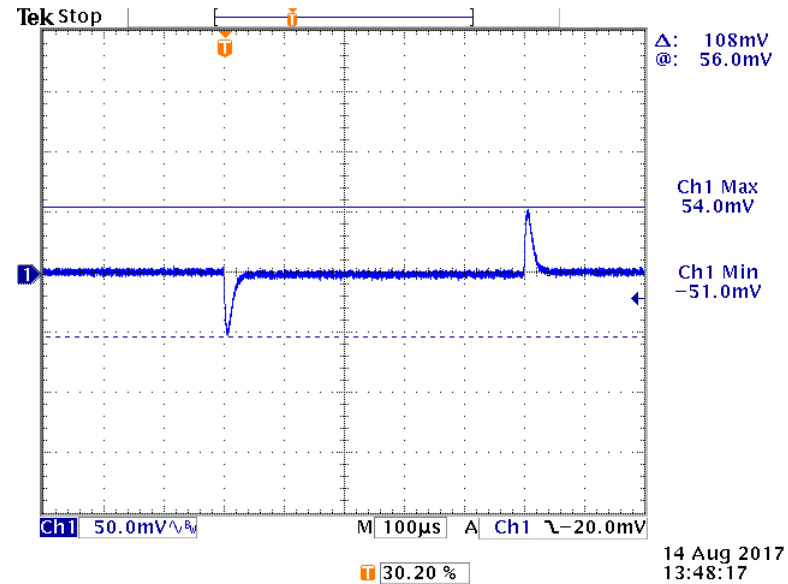

**Vpp = 108mV, less than ±4% of VOUT @2.5A/us, 1A to 2A**

MPM3620A, VIN=12V, VOUT=1.8V, COUT=22\*2uF

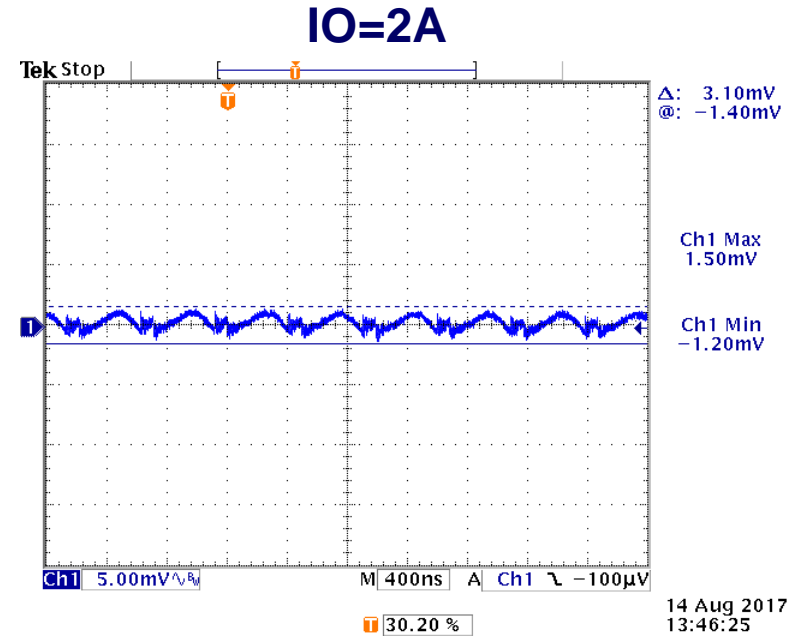
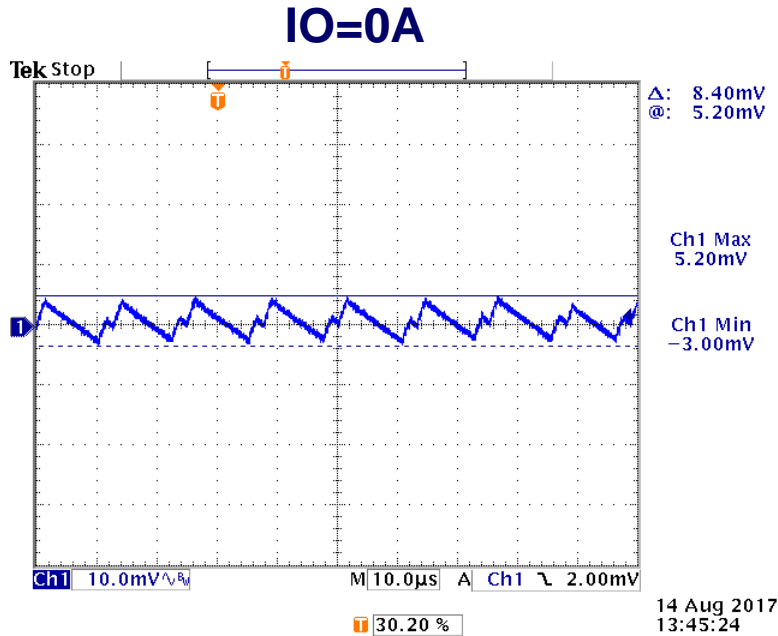

**Vpp = 3.1mV @ full load, less than 0.5% of VOUT**

MPM3695-25, VIN=12V, VOUT=1.2V, COUT=6 x 100uF

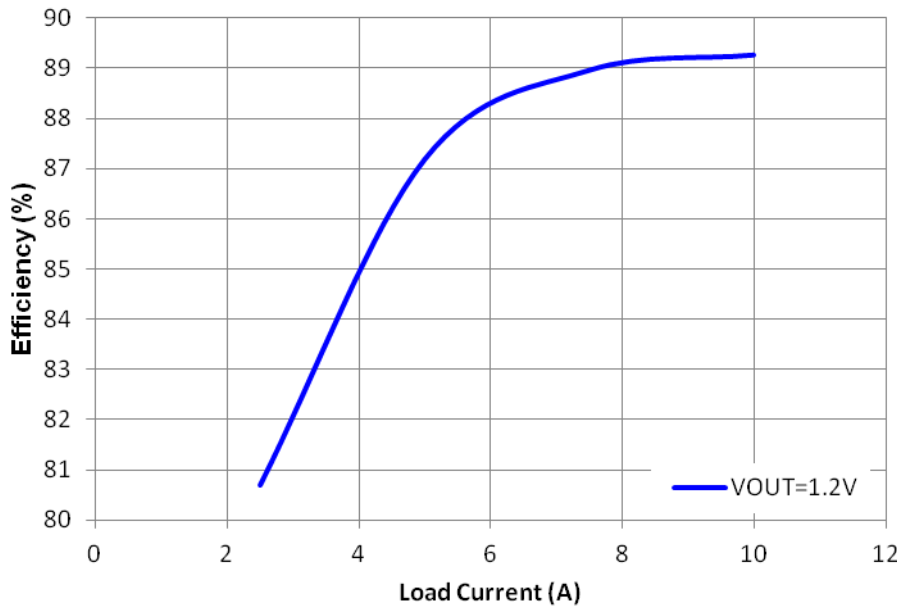

**Max Efficiency 89.3%**

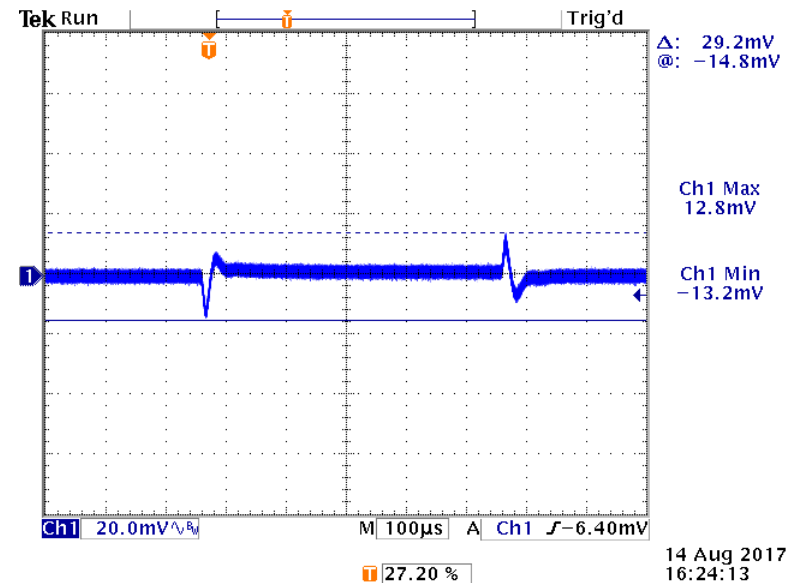

**Vpp = 29.2mV, less than ±2% of VOUT @5A/us, 5A to 10A**

MPM3695-25, VIN=12V, VOUT=1.2V, COUT=6 x 100uF

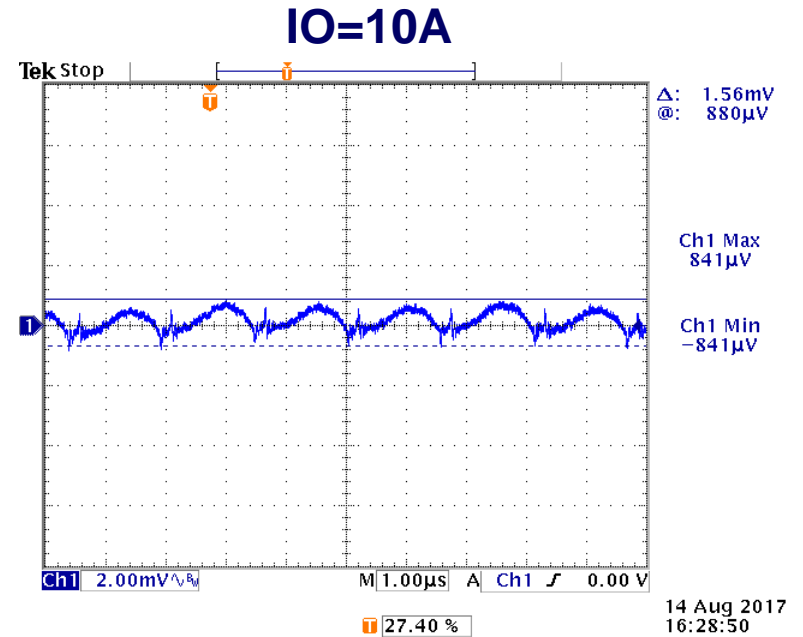
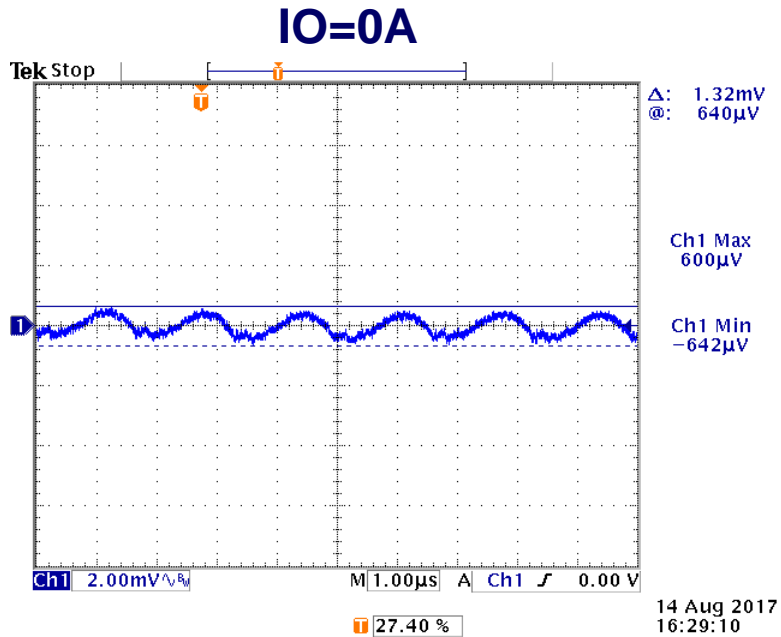

Max Vpp = 1.56mV, less than 0.5% of VOUT

MPM3610A, VIN=12V, VOUT=1.2V, COUT=22uF

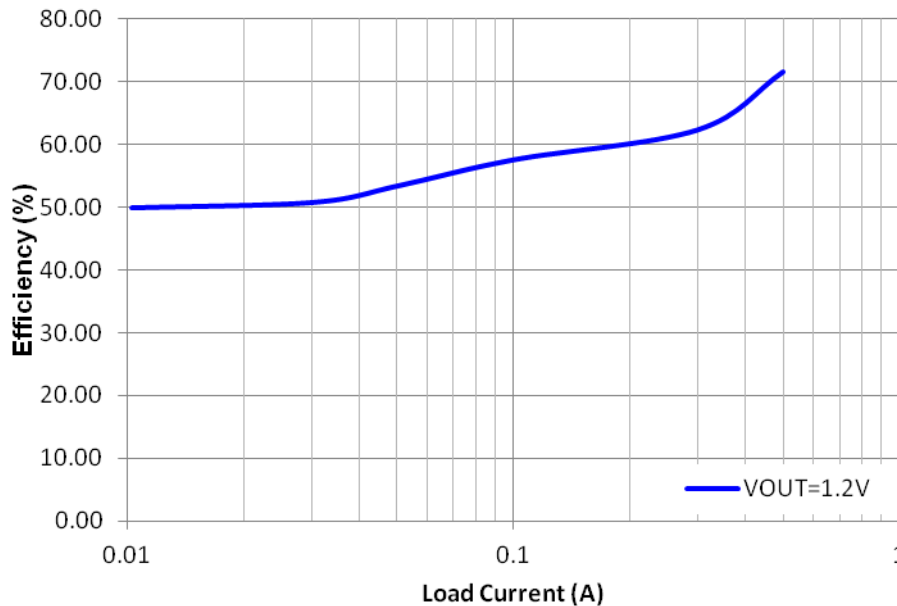

**Max Efficiency 71.5%**

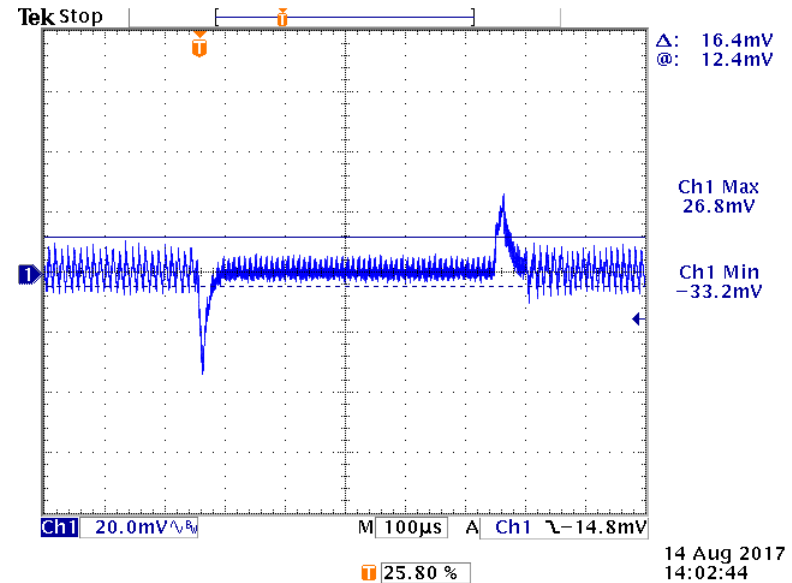

**Vpp = 60mV, less than ±3% of VOUT @2.5A/us, 0A to 0.5A**



MPM3610A, VIN=12V, VOUT=1.2V, COUT=22uF

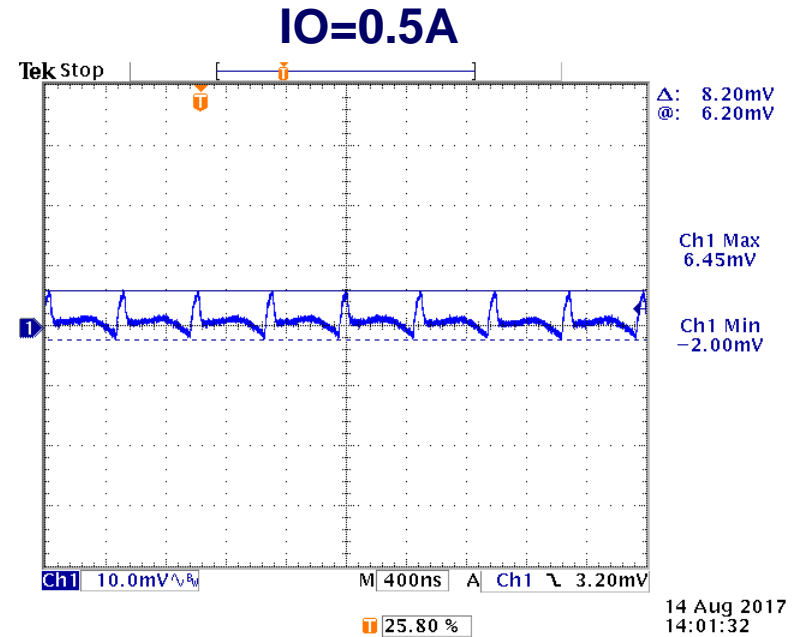
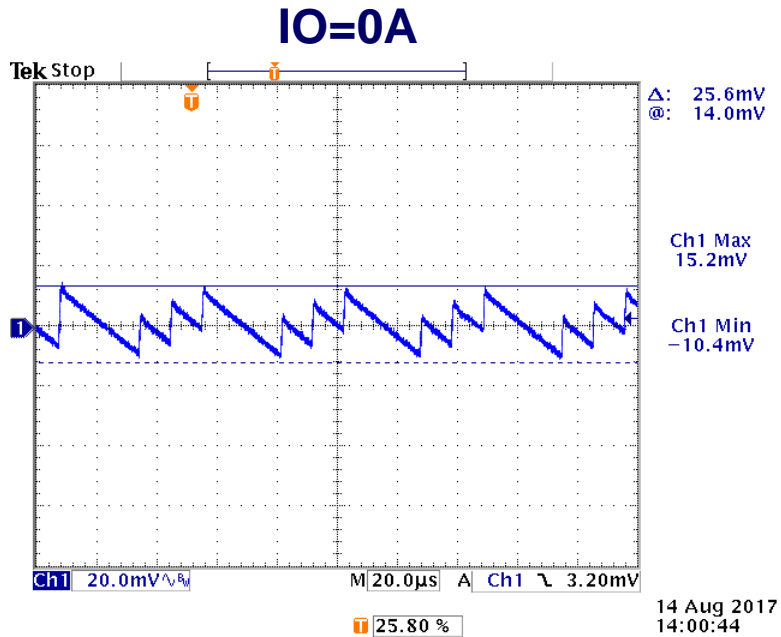

**Vpp = 8.2mV @ full load, around 0.5% of VOUT**

MPM3610A, VIN=12V, VOUT=0.85V, COUT=22uF

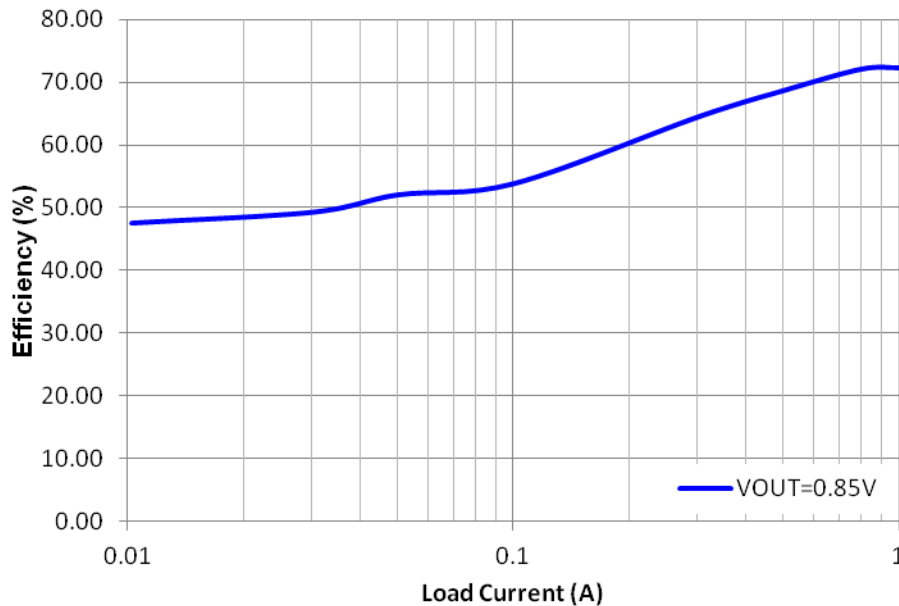

**Max Efficiency 72.3%**

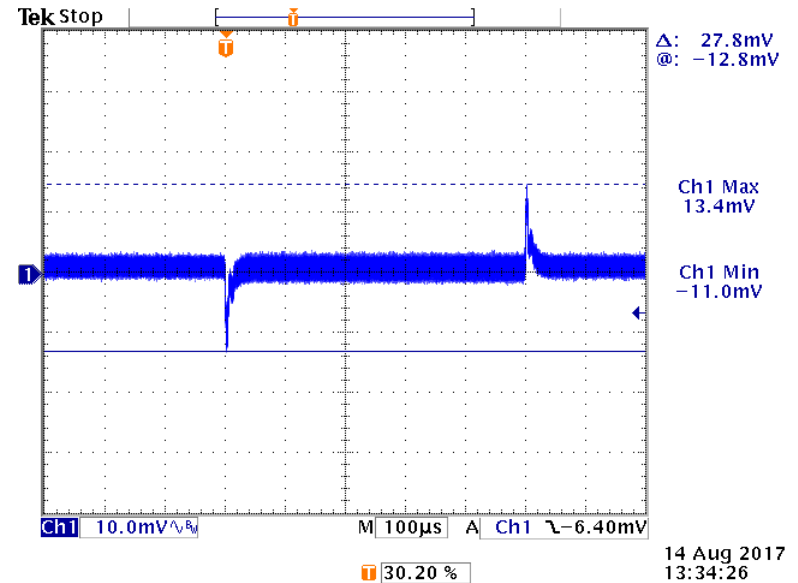

**Vpp = 27.8mV, less than ±2% of VOUT @5A/us, 0.5A to 1A**

MPM3610A, VIN=12V, VOUT=0.85V, COUT=22uF

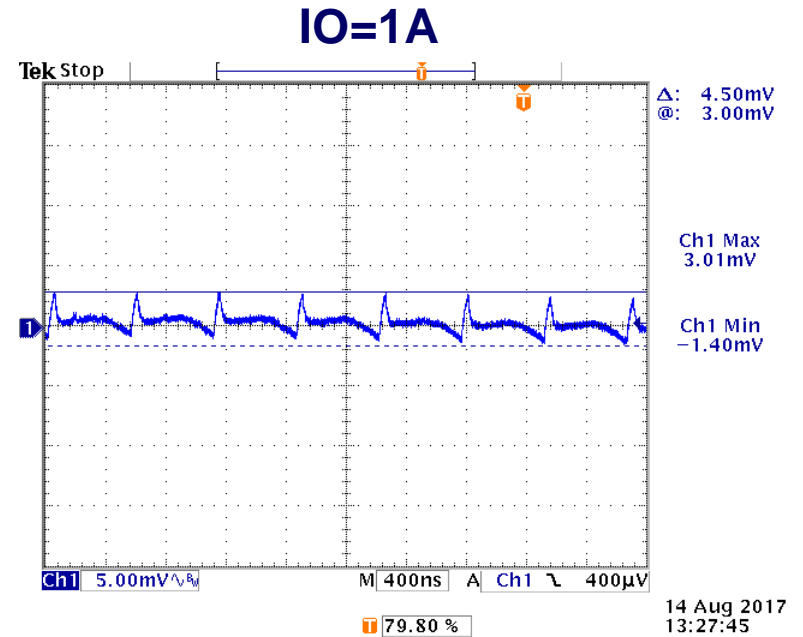
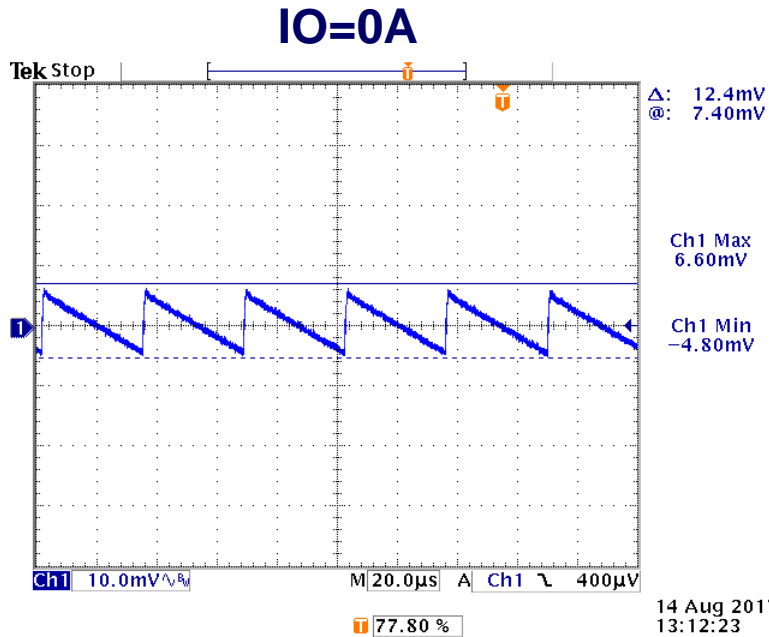

**Vpp = 4.5mV @ full load, around 0.5% of VOUT**

MPM3695-10, VIN=12V, VOUT=0.9V, COUT=6 x 100uF

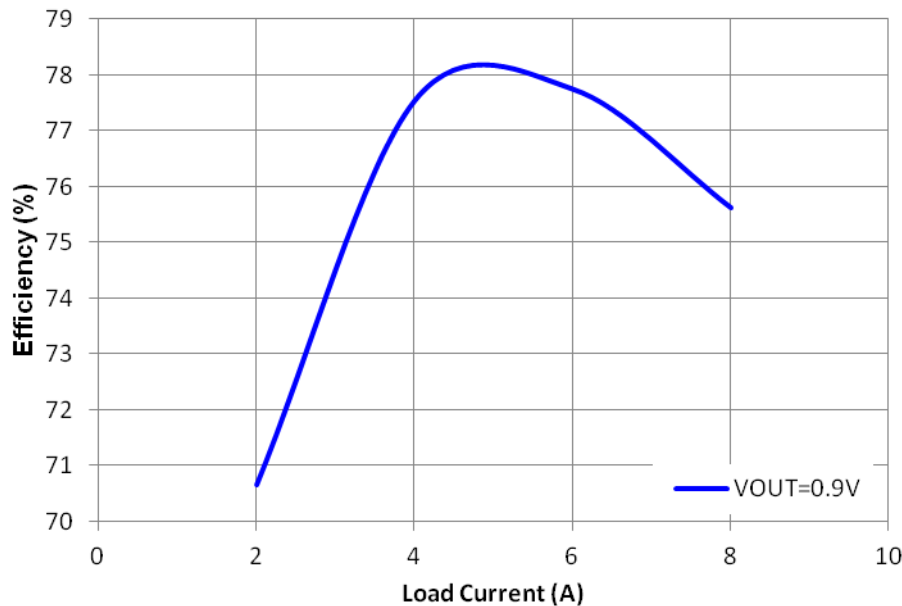

**Max Efficiency 78%**

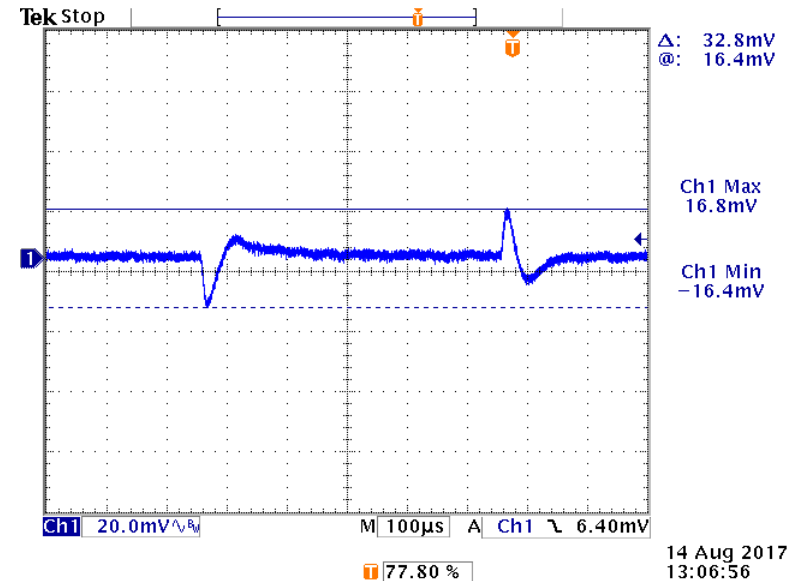

**Vpp = 32.8mV, less than ±2% of VOUT  
@5A/us, 2A to 8A**

MPM3695-10, VIN=12V, VOUT=0.9V, COUT=6 x 100uF

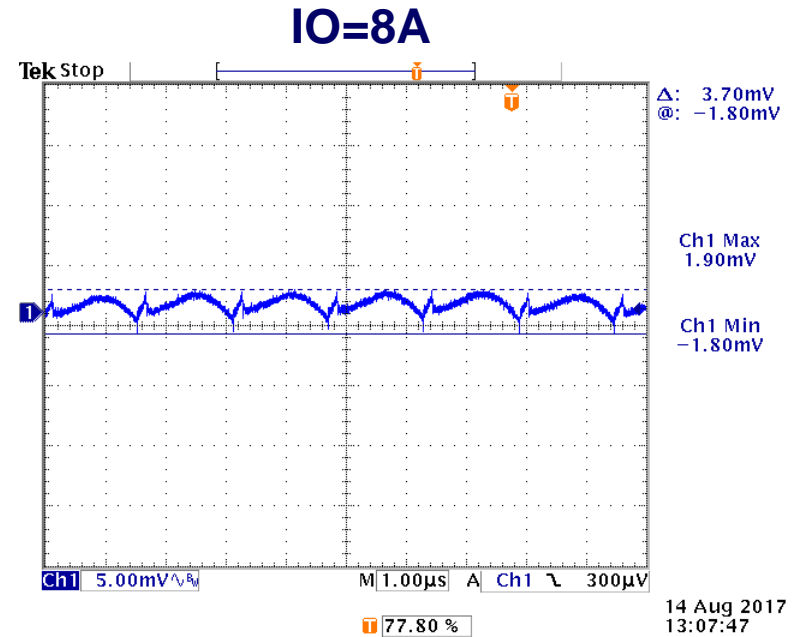
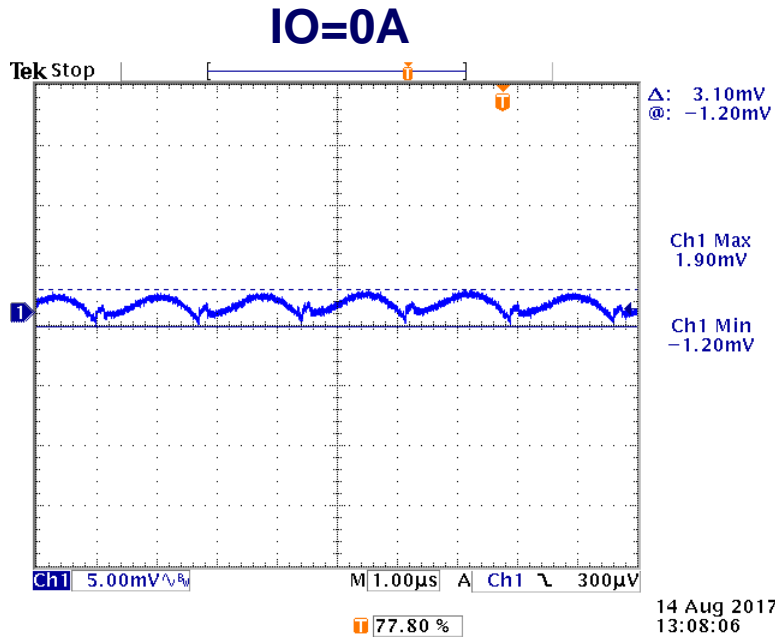

**Max Vpp = 3.7mV, less than 0.5% of VOUT**

MPM3610A, VIN=12V, VOUT=1.8V, COUT=22uF

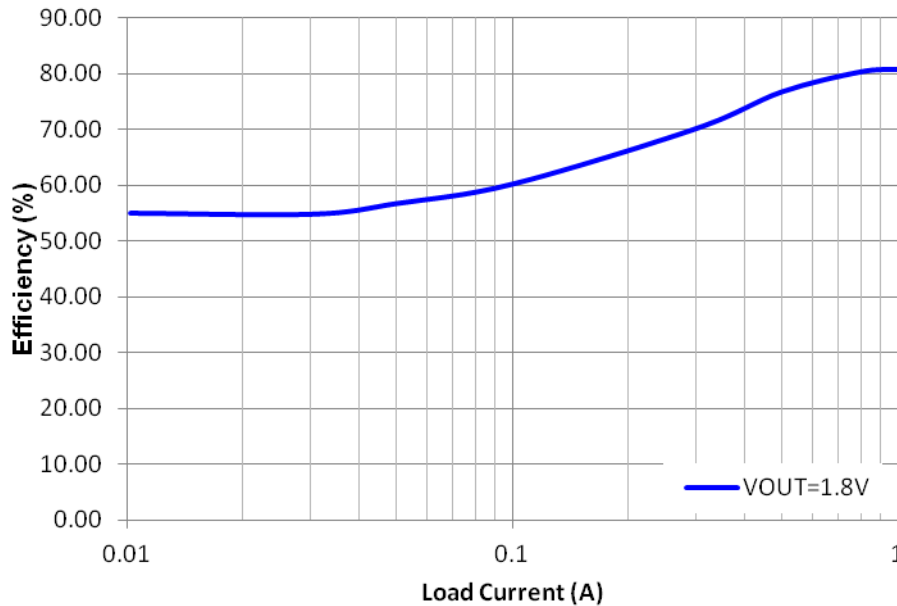

**Max Efficiency 80.7%**

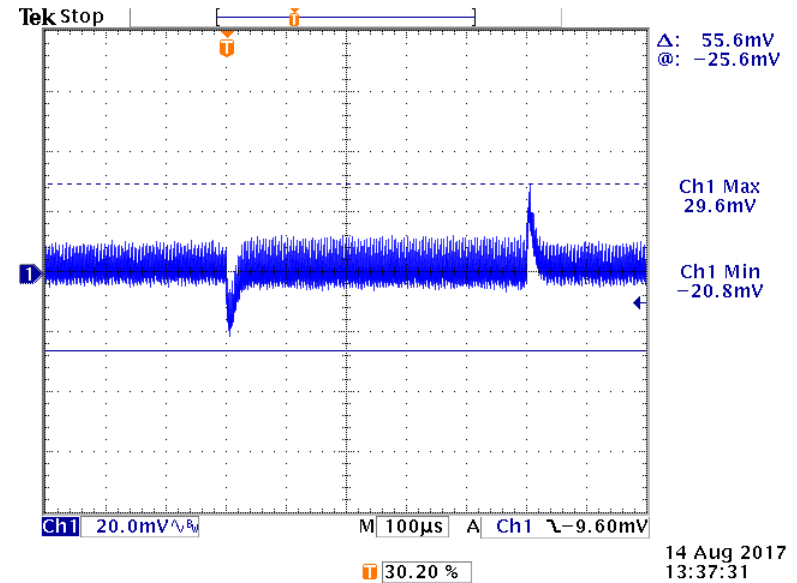

**Vpp = 27.8mV, less than ±2% of VOUT @5A/us, 0.5A to 1A**

MPM3610A, VIN=12V, VOUT=1.8V, COUT=22uF

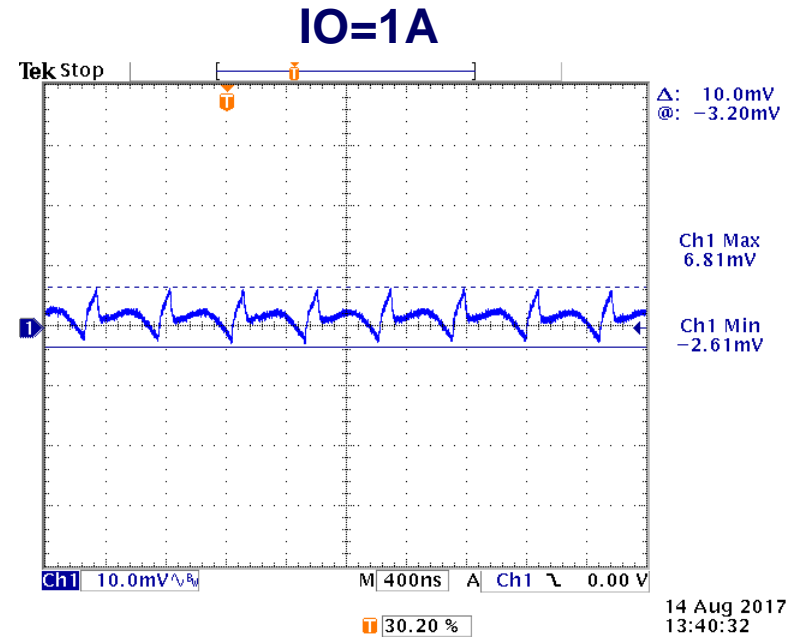
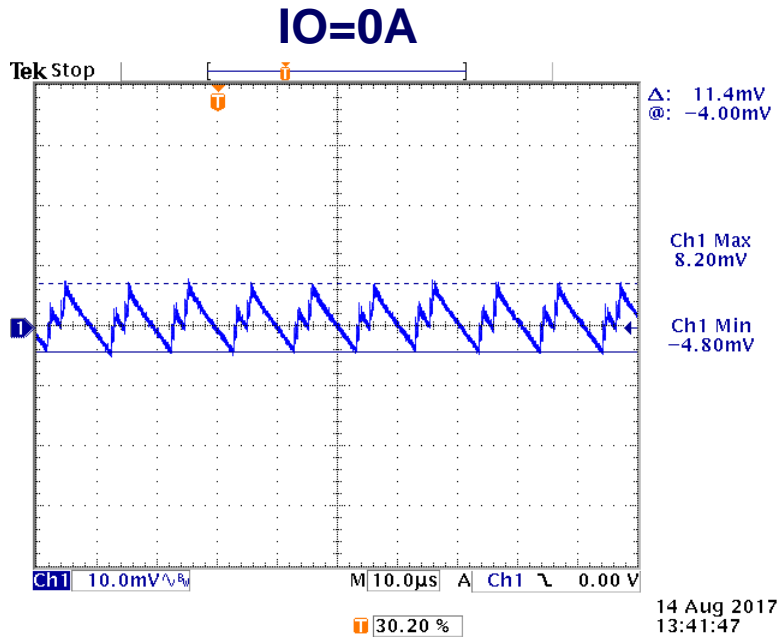

**Vpp = 10mV@ full load, around 0.5% of VOUT**



MPM3606A, VIN=12V, VOUT=2.5V, COUT=22uF

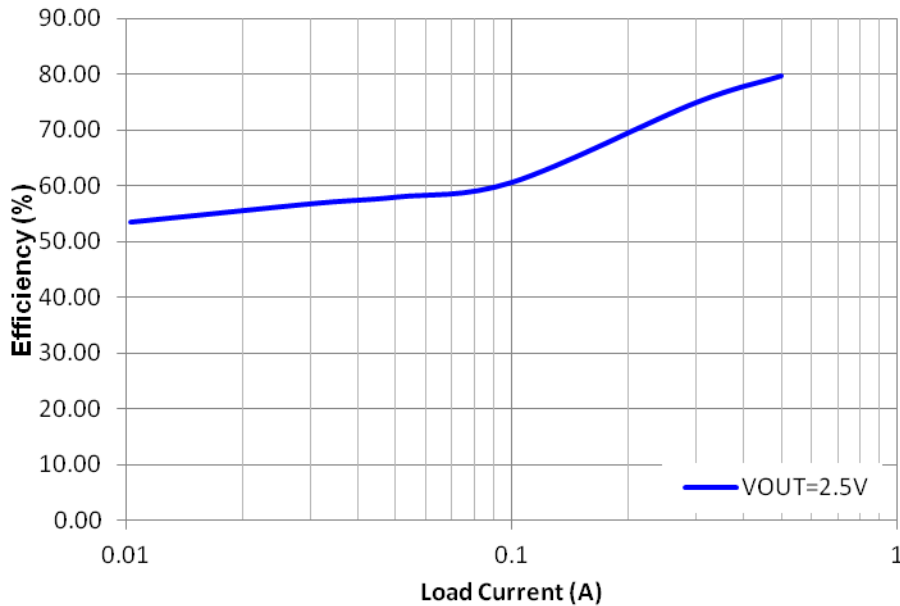

**Max Efficiency 80%**

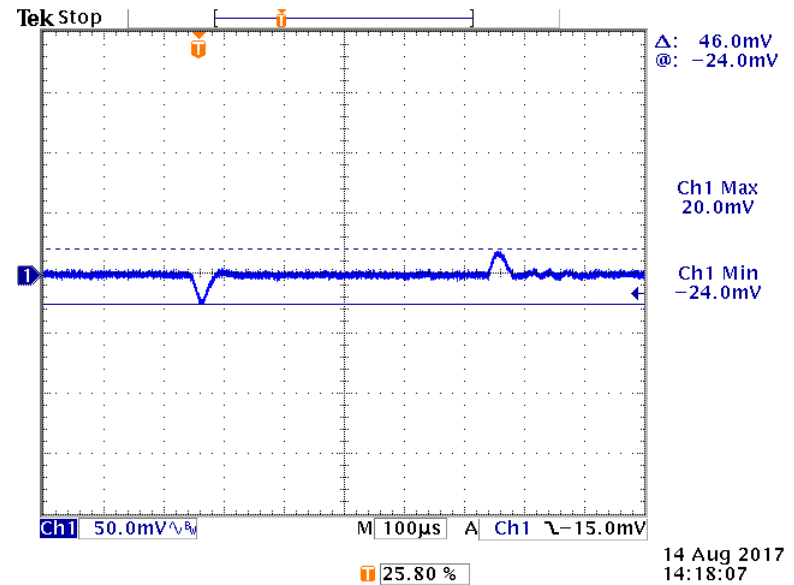

**Vpp = 46mV, less than ±1% of VOUT  
@2.5A/us, 0A to 0.5A**

MPM3606A, VIN=12V, VOUT=2.5V, COUT=22uF

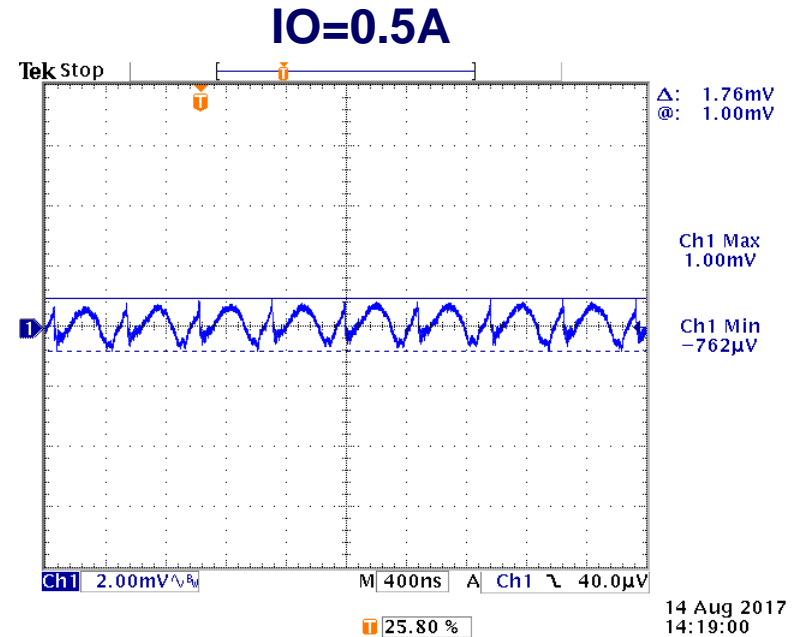
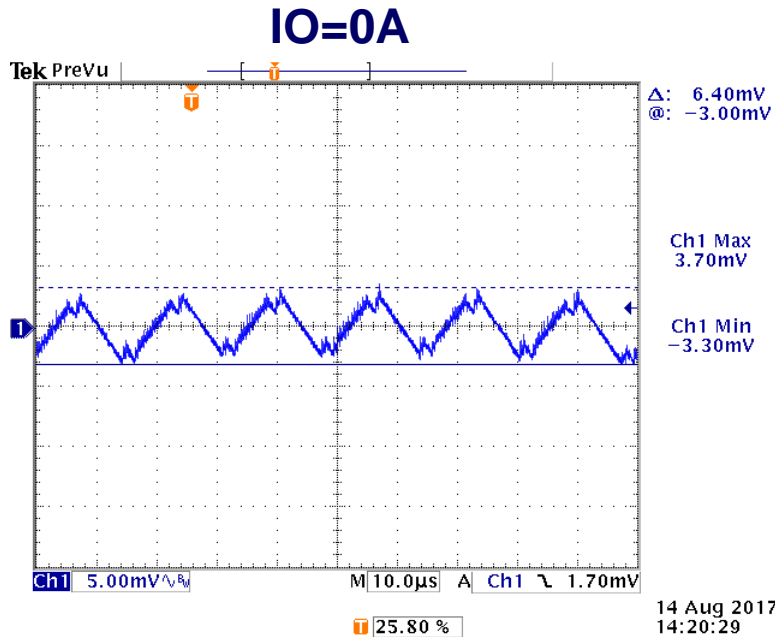

**Vpp = 1.76mV @ full load, less than 0.5% of VOUT**

MPM3606A, VIN=12V, VOUT=1.8V, COUT=22uF

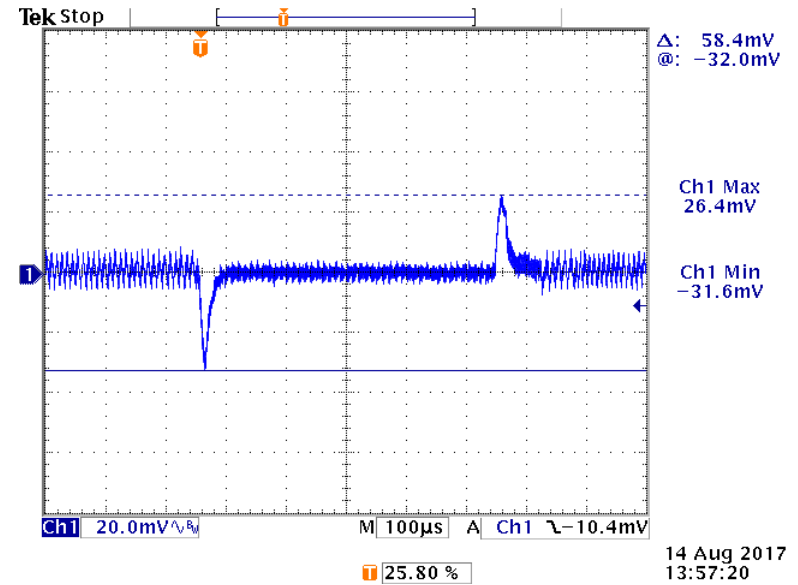
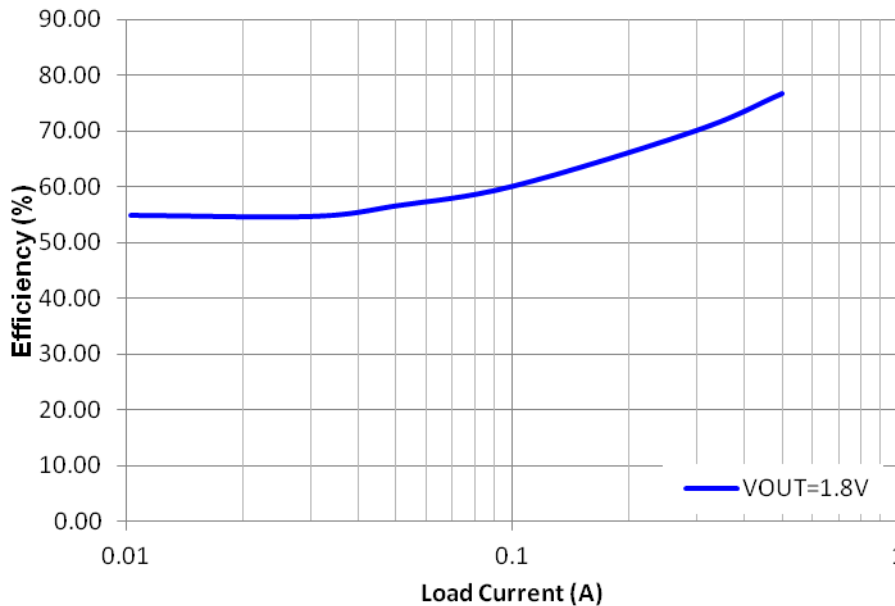

**Max Efficiency 77%**

**Vpp = 58.4mV, less than ±2% of VOUT @2.5A/us, 0A to 0.5A**

MPM3606A, VIN=12V, VOUT=1.8V, COUT=22uF

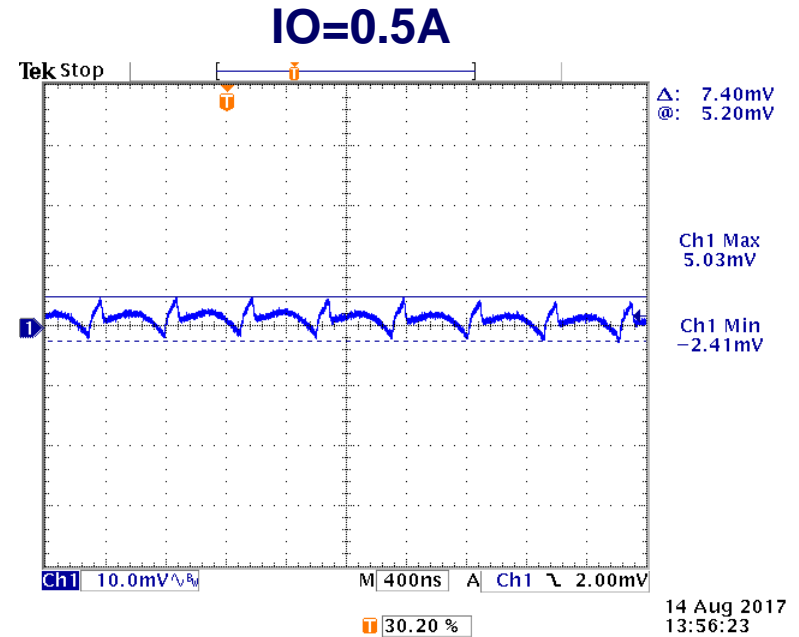
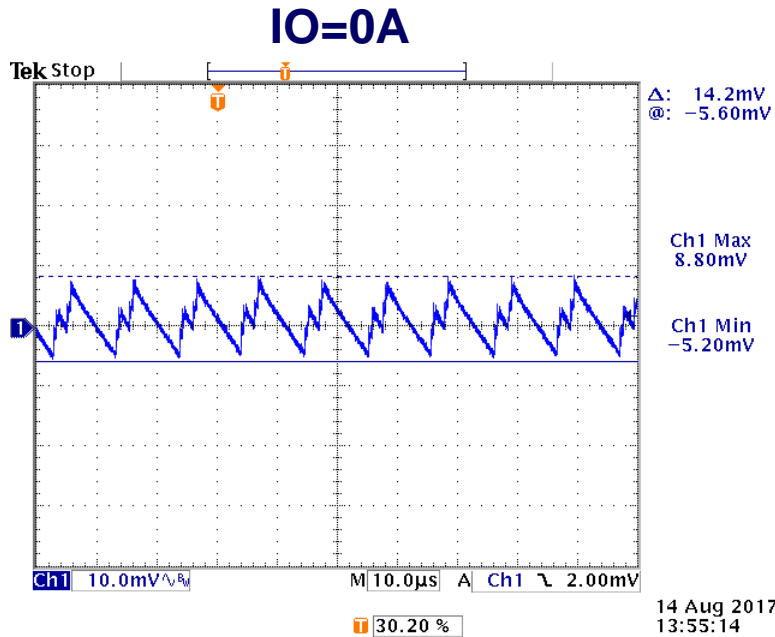

**$V_{pp} = 7.4\text{mV}@$  full load, less than 0.5% of VOUT**

MPM3610A, VIN=12V, VOUT=1.5V, COUT=22uF

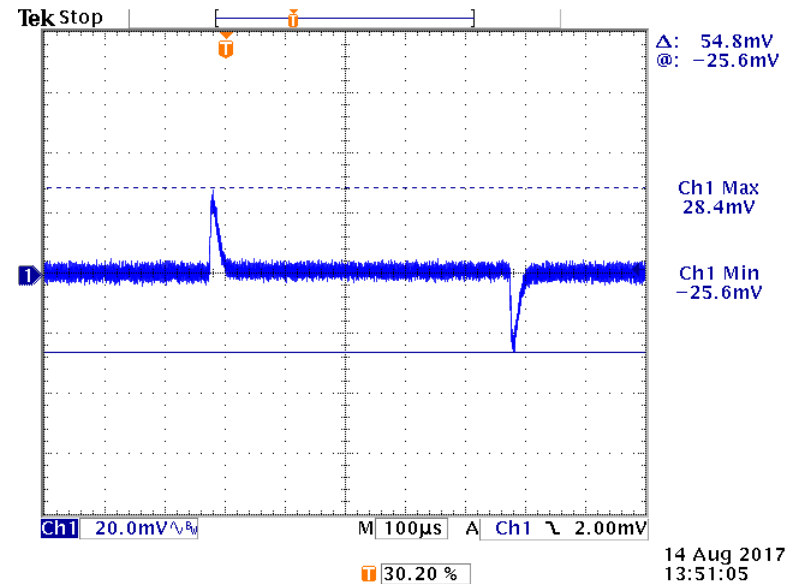
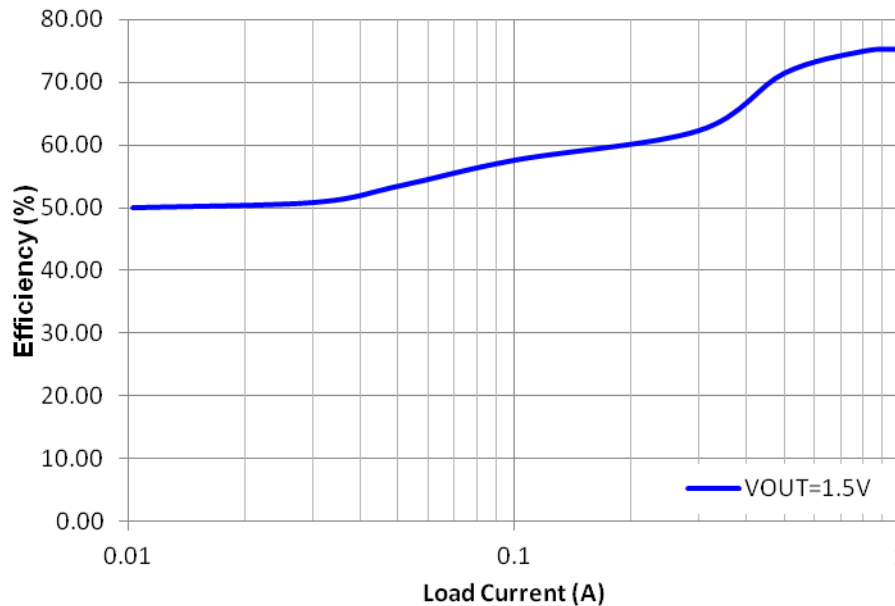

**Max Efficiency 75%**

**Vpp = 54.8mV, less than ±2% of VOUT  
@2.5A/us, 0.5A to 1A**

MPM3610A, VIN=12V, VOUT=1.5V, COUT=22uF

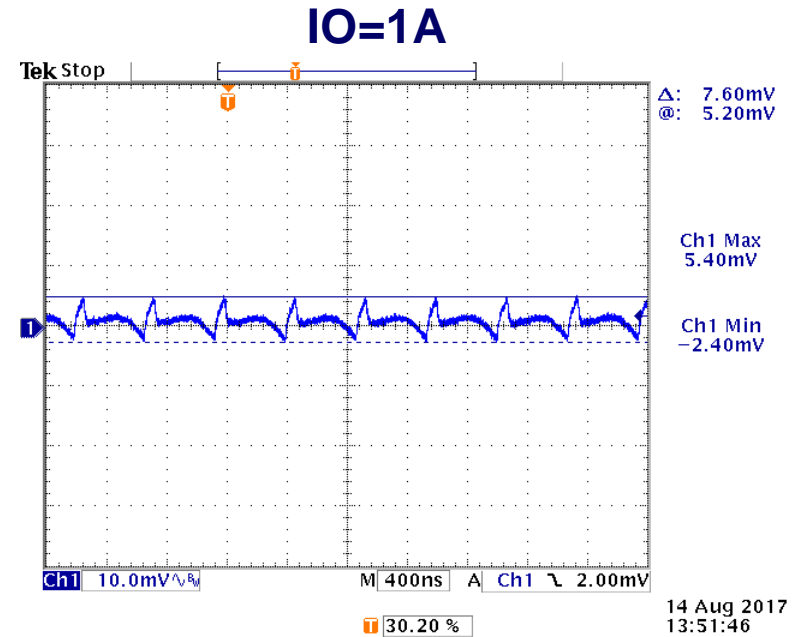
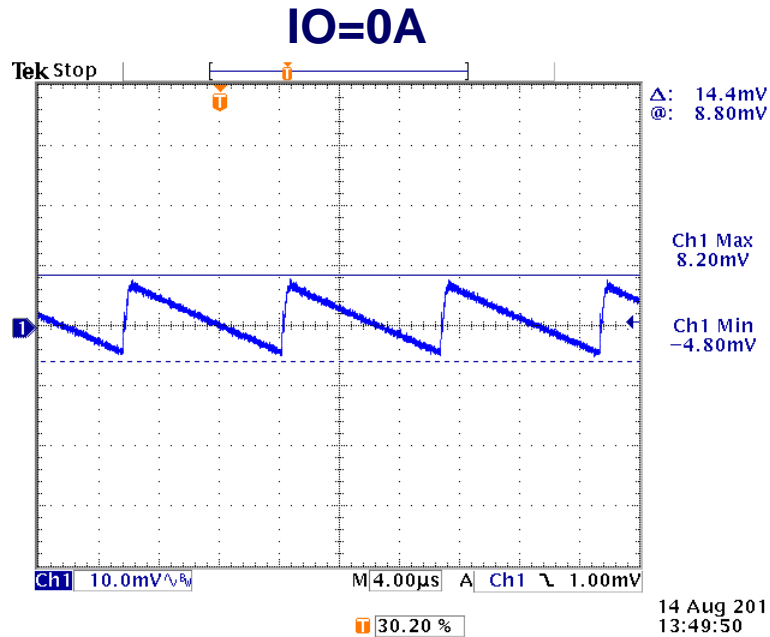

**Vpp = 7.6mV @ full load, around 0.5% of VOUT**